



● Cat. No. 040E-11-2021

PACKINGS

HYDRAULIC SEALING SYSTEMS

NOK CORPORATION

Everything starts with the packing.

Industrial equipment is facing a new innovation with remarkably developing mechatronics and remarkably advancing factory automation. Among other things, the performance of NOK's packing is dramatically improving in the field of actuation and the control of hydraulic and pneumatic equipment.

NOK has been advancing its unique research on rubber material, resin material and lip shape that determine the sealing performance of packing, and since 1960, NOK has been improving and reforming the rubber material "Iron rubber", developing it as the standard material for packing. This material can be said to be an ideal packing-dedicated polyurethane elastomer developed considering the balance of the physical property and being examined from every angle. NOK has also been positively developing materials such as nitrile rubber, fluorine rubber, hydrogenated nitrile rubber, and silicone rubber, and at the same time, has been developing and improving engineering plastic materials such as polytetrafluoroethylene resin and polyamide resin by making full use of NOK's unique compounding technique,

NOK PACKINGS

thus always providing “one step ahead” materials and meeting every need of the customers. In the fields requiring technology high enough to claim “more than anything else, the quality of the sealing equipment shows the industrial level of that country”, NOK has continued to achieve unshaken performance for more than half a century.

NOK has been performing its unique in-house research, and also collaborating with NOK’s group companies overseas, Freudenberg (Germany), and Freudenberg-NOK(USA), thus performing close technological exchange, exchanging information on market trends, and providing cutting-edge world technology.

Based on this performance, NOK is also performing research and development on new products in the new fields of electronics, nuclear power, and high polymer chemistry, and also in the fields of chemitronics, optronics, and biotechnology, looking ahead to the future.

———— Various know-how cultivated over a long period of time in this way are gaining high reliability from a wide variety of world industrial fields. In the future, to meet the users’ increasing highly diversified needs, NOK will focus on the development of seal related products such as next-generation packing and engineering plastics, to further improve our technology.



Before using the packing

1. Storage Notes

When storing packings :

1. Do not open the packaging unnecessarily. "Dust" may stick to the packing or scratch it.
2. Avoid exposure to direct sunlight and store in a cool place.
Ultraviolet light and humidity may promote deterioration and dimensional change of rubber and resin material.
3. When storing products already unpacked, be careful that foreign materials do not stick or become embedded.
Store them in their original condition, in tightly sealed polyamide to prevent dimensional change resulting from humidity.
4. Do not replace packings near any heat source such as a boiler, stove, etc. Heat may deteriorate the material.
5. Do not place packings near electric motors or equipment generating ozone.
6. Avoid hanging packings with a nail, wire or suspending them with a string as this may cause deformation and scratches on the top end of the lip.
7. Sometimes, color changes or white powder appears on the surface of packings (blooming phenomenon).
This will not affect the function of the packing.
8. Rareflon rings of combination seals may be easily scratched if dropped or impacted by an external force.
Handle with care.

2. Storage Period of Packings

The following table shows the storage period of packings.

Use the storage period as a guide when storing.

Product	Material	Storage period
Rubber Material Products	Iron rubber* (PUR)	10 years
	Nitrile rubber (NBR)	10 years
	Hydrogenated nitrile rubber (H-NBR)	10 years
	Silicon rubber (VMQ)	20 years
	Fluoro rubber (FKM)	20 years
Rubber Baked Products	Nitrile rubber (NBR)	10 years
	Fluoro rubber (FKM)	10 years
Resin	Rareflon* (PTFE)	20 years
	Polyamide (PA)	20 years
	Resin fiber polyester	20 years
	Fabric reinforced phenolic (—)	20 years

*"Iron Rubber" and "Rareflon" are trade registered trademarks of NOK CORPORATION.

A registered trademarks of NOK CORPORATION	General name
Iron rubber	Polyurethane elastomer
Rareflon	Polytetrafluoroethylene resin

- The storage periods shown above are applicable to products sealed in standard packing and stored in a cool dry place away from direct sunlight.
- Dimensional changes due to moisture absorption of polyamide resin are not covered since it would depend greatly on the storage environment.
- The indicated storage periods do not account for rust formation on the metal parts of bonded seal products, since rust is largely influenced by the storage environment.
- Before using a packing that has been kept in storage for an extended period of time, check that it is free from rust.

- All compatibility data, application information, design & material information and technical data in this catalogue are compiled as reference material to make a basic packing selection.

A selected standard design from this catalogue may not conform to the actual use of an application, due to unknown factors of the application.

Please confirm the actual compatibility of a selected product with your application before using it.

- The contents are subject to change without notice.

The packing described in this catalog is not designed and manufactured to be suitable for medical devices. Do not use this packing for medical devices touching bodily fluids or body tissues.

HYDRAULIC SEALING SYSTEMES

CONTENTS

A	WHAT ARE NOK HYDRAULIC SEALING SYSTEMS	7 ~ 12	A
B	SELECTING, TYPES, AND FEATURES	13 ~ 32	B
C	TYPES AND FEATURES OF NOK PACKINGS	33 ~ 38	C
D	APPLICATION EXAMPLES OF NOK PACKINGS	39 ~ 56	D
E	DIMENSION TABLES FOR NOK PACKINGS	57 ~ 226	E
F	HANDLING AND INSTALLATION OF NOK PACKINGS	227 ~ 236	F
G	WHEN LEAKAGE OCCURS	237 ~ 250	G
H	TECHNICAL DATA	251 ~ 270	H
I	REFERENCE MATERIAL	271 ~ 303	I

A

WHAT ARE NOK HYDRAULIC SEALING SYSTEMS?

What are hydraulic sealing systems? —————	8
What are lip packings? —————	9
What are squeeze packings? —	9
How do packings seal? —————	10
Lubrication characteristics —	11

A. WHAT ARE NOK HYDRAULIC SEALING SYSTEMS?

Hydraulic Sealing Systems

are general terms describing sealing systems (seals) used for moving parts (usually with reciprocal movement) of hydraulic equipment. Different types of seals may be combined, depending on the application.

Different types of seals are classified...

below according to the application, form and material. Lip packings are most frequently used for reciprocal moving parts. An application example for a hydraulic cylinder is shown in Fig. A-1.

Clasofocacion of Sealing Equipment

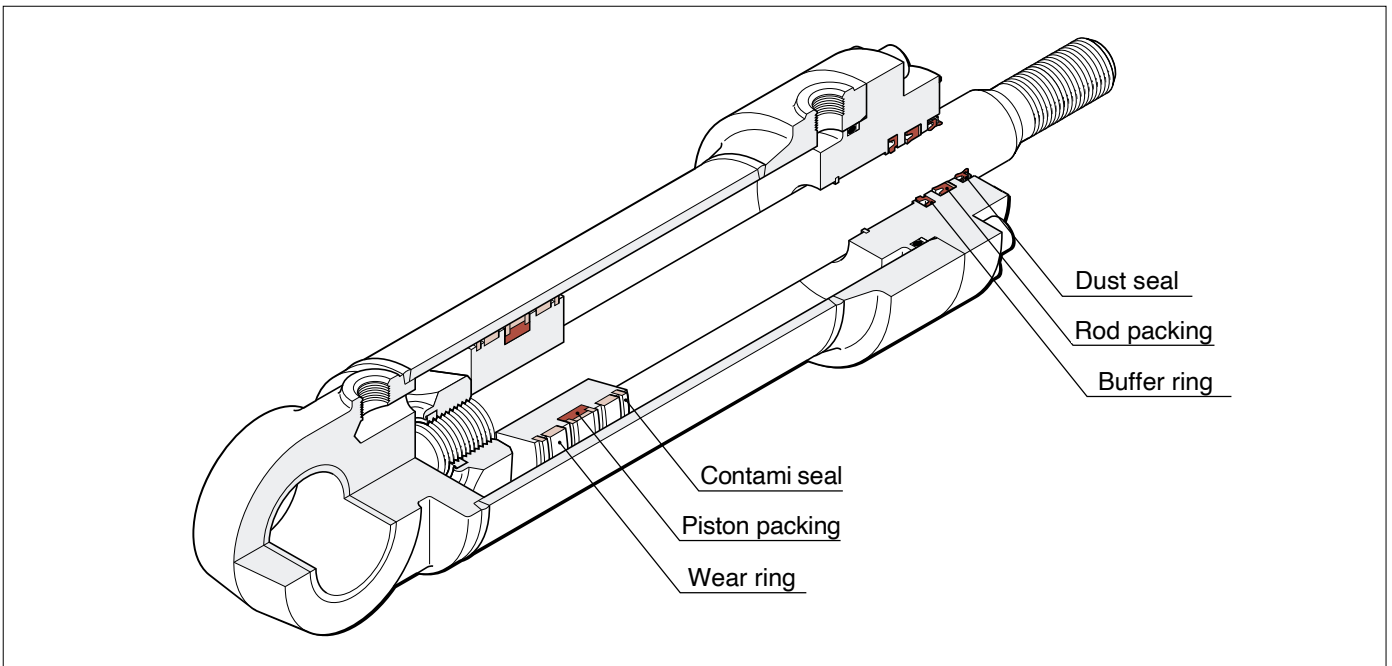
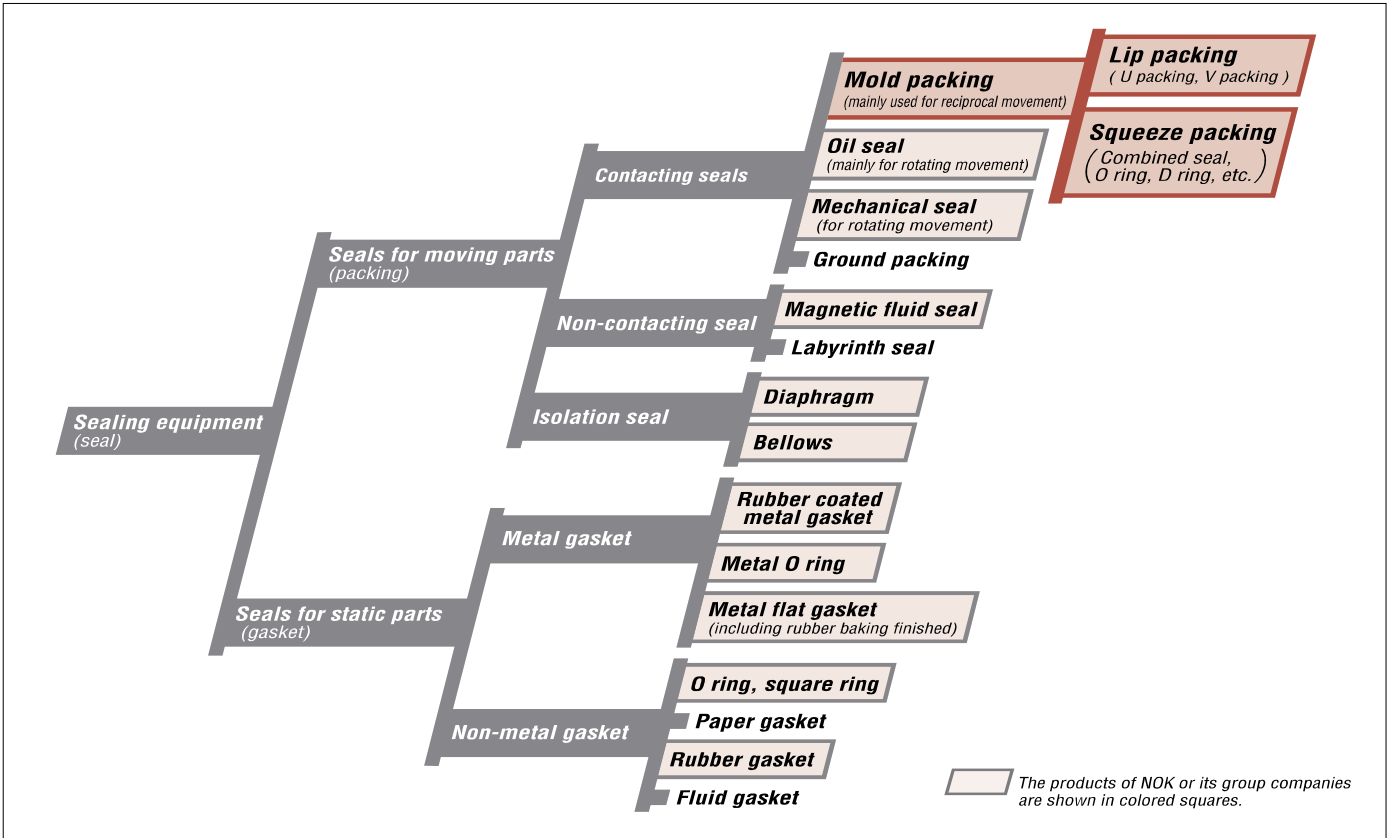

〈Fig. A-1〉 Application example for hydraulic cylinder

For effective application, hydraulic sealing systems should combine various sealing devices most appropriate for specific operating conditions and usage.

■ What are lip packings?

As its name suggests, a U packing is a general term describing a packing with a U-shaped groove as shown in **Fig. A-2**. This packing has an inner lip “A” and outer lip “B”.

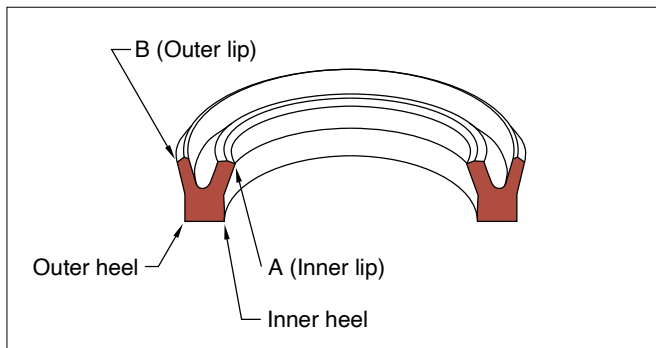

〈Fig. A-2〉 U packing

Fig. A-3 shows a U packing deformed by interference when fitted into the installation groove, which makes the lip contact with the rod. When fluid pressure (oil pressure) is added, the heel of the packing becomes deformed so the complete sliding surface is intact with the rod surface. The condition of contacting pressure distribution of the lip and heel is closely related with the sealing characteristics of the packing.

The relationship between sealing characteristics and contacting pressure distribution is described on **page A-4**.

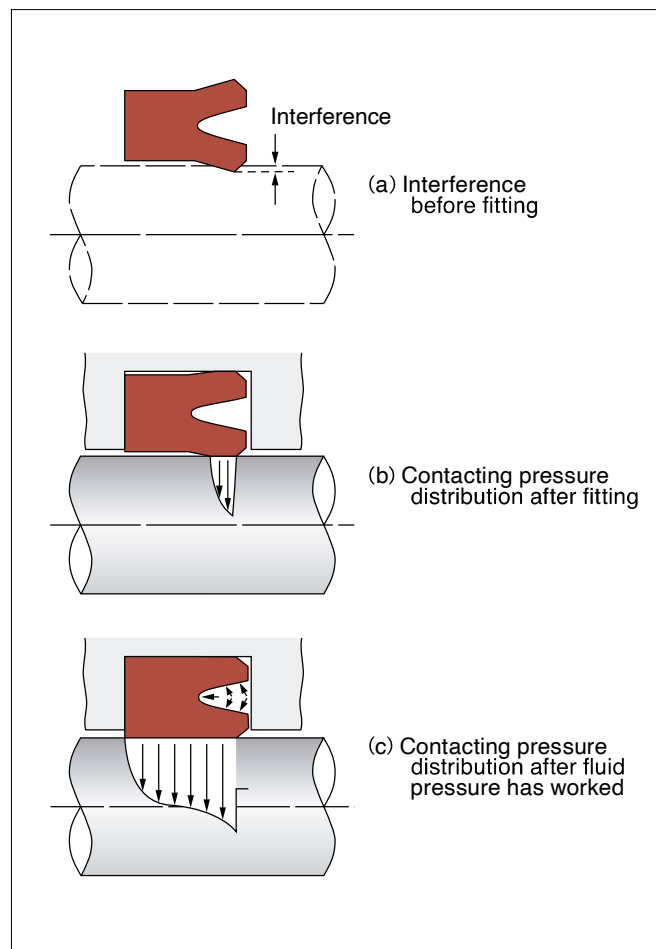

〈Fig. A-3〉 Contacting pressure distribution of U packing

■ What are squeeze packings?

This type of packing applies a rubber-like elastic object onto the sealed surface.

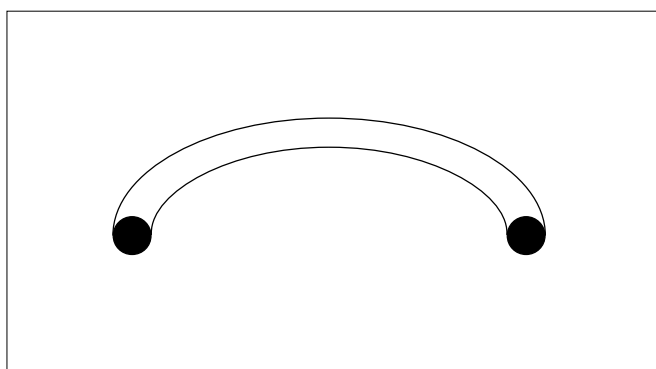

〈Fig. A-4〉 O ring

An O-ring (**Fig. A-4**) with an O-shaped profile is a typical squeeze packing. Significant pressure on the sealing surface is required to compress and deform the profile for sealing. For this reason, significant frictional resistance and high-sliding frictional heat is created resulting in a short life of the packing. To reduce sliding frictional resistance and frictional heat, the compression and deformation ratio of the O-ring should be decreased, which will, however, reduce the sealing ability.

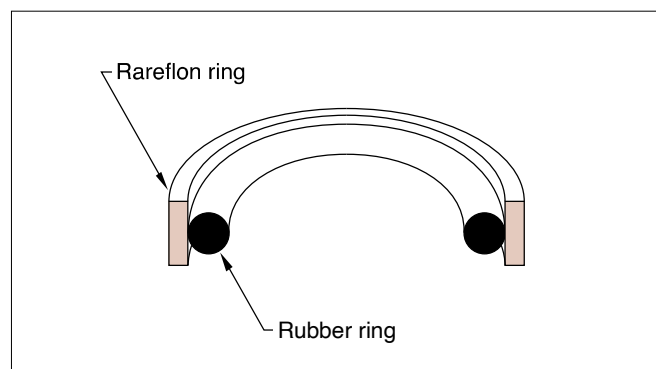

〈Fig. A-5〉 Example of combined seal

To decrease friction, a combined seal (called a SP seal) has been developed with low-friction rareflon (PTFE) on the sliding surface (**Fig. A-5**).

Compared to the lip packing, the combined seal has a lower sealing ability but offers lower sliding resistance. Because of these characteristics, this seal is mainly used as a piston packing for hydraulic cylinders.

How do packings seal?

By what means do packings for reciprocal movement seal hydraulic fluid? A U packing serves as a good example to illustrate sealing capability.

As shown in Fig. A-6, when the rod moves to the right, the U packing is contacting with the rod under pressure distribution created by the peak pressure ($P_{1 \max}$) that is higher than the inner pressure (P_1). Thickness of the fluid/oil passing through the packing becomes thinner as the absolute value of the maximum contacting pressure gradient of the hydraulic pressure of the pressure distribution $|dp/dx|_{\max,P}$ becomes greater.

Conversely, when the rod moves to the left by the inner pressure (P_2) on the U packing (Fig. A-7), the thickness of the fluid/oil passing through the packing depends on absolute value of the maximum contacting pressure gradient of the atmospheric pressure $|dp/dx|_{\max,M}$.

To reduce friction, a fluid/oil film on the sliding surface of the packing is necessary. NOK designs packings with well-balanced contacting pressure distribution to form optimum fluid/oil film on the sliding surface.

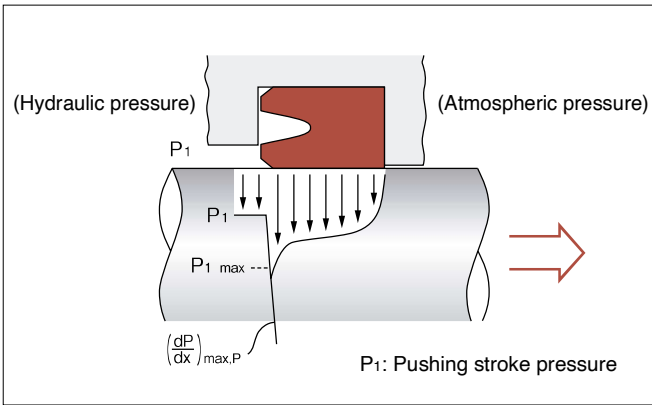

(Fig. A-6) Contacting pressure distribution (pushing stroke)

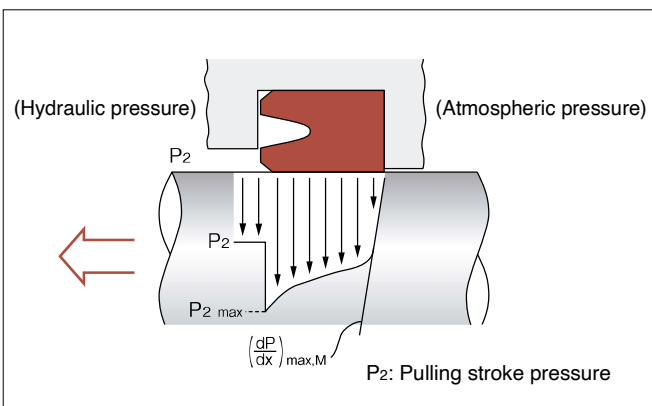

(Fig. A-7) Contacting pressure distribution (pulling stroke)

The minimum oil film thickness of the sliding surface depends on the maximum contacting pressure gradient, speed, and oil viscosity, and can be determined from the formula (1) below.

$$h = \sqrt{\frac{8\mu U}{9 |dp/dx|_{\max}}} \quad \dots\dots\dots (1)$$

μ : Oil viscosity (Pa · s)

U : Speed (m/s)

$|dp/dx|_{\max}$: Absolute value of the maximum contacting pressure gradient (Pa/m)

In the case of a hydraulic cylinder, the thickness of the fluid/oil film created at the pushing stroke (when the rod extends) (h_P) and at the pulling stroke (when the rod compresses) (h_M) can be determined respectively by the formula (2) and (3).

$$h_P = \sqrt{\frac{8\mu U_P}{9 |dp/dx|_{\max,P}}} \quad \dots\dots\dots (2)$$

$$h_M = \sqrt{\frac{8\mu U_M}{9 |dp/dx|_{\max,M}}} \quad \dots\dots\dots (3)$$

U_P : Speed of the pushing stroke (m/s)

U_M : Speed of the pulling stroke (m/s)

$|dp/dx|_{\max,P}$: Absolute value of the maximum contacting pressure gradient of hydraulic pressure at the pushing stroke (Pa/m)

$|dp/dx|_{\max,M}$: Absolute value of the maximum contacting pressure gradient of atmospheric pressure at the pulling stroke (Pa/m)

Therefore, if the speed of both the pushing and pulling stroke is the same ($U_P=U_M$), $h_P \leq h_M$ is the condition for sealing and the packing satisfying the formula below

$$|dp/dx|_{\max,P} \geq |dp/dx|_{\max,M}$$

can be regarded to have a good sealing performance.

■ Lubrication characteristics

One of the most important features of a packing for reciprocal movement is to have low friction on the sliding surface to assure long life.

To reduce friction, proper lubricant (oil film) is necessary for the sliding surface of the packing for reciprocal movement. How do lubrication characteristics change according to operating conditions?

To understand globally the lubricating requirements of a packing's sliding surface, it is necessary to know dynamic friction characteristics when pressure, speed and fluid oil viscosity effecting the surface have changed.

An example of a U packing for a hydraulic cylinder rod helps explain this. The relationship between non-dimensional characteristics value G , that is determined by the form of U packings and its operating condition and the friction coefficient f , is determined in **Fig. A-8**. The range where the friction coefficient has a positive gradient is described as fluid lubrication in the lubrication theory. Within this range, the rod and the packing are in contact with each other through oil film, assuring a long packing life without wearing, even if a relative reciprocal movement occurs.

Within the range where the coefficient (f) has a negative gradient, the oil film between the packing and the rod is destroyed. This range is called the non-fluid lubrication area.

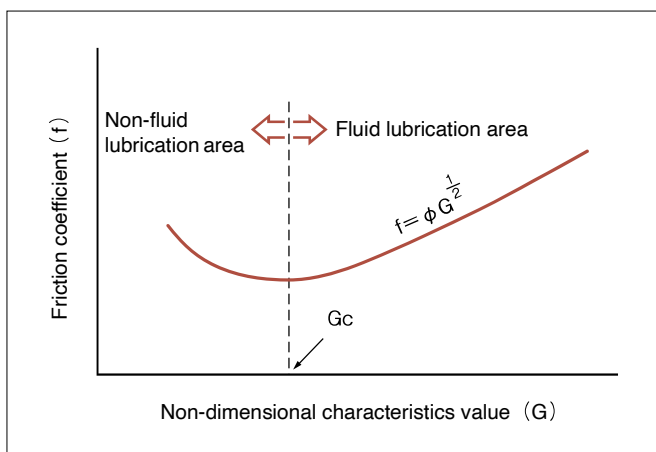

〈Fig. A-8〉 Example of non-dimensional characteristics graph (U packing)

Where,

- f : Friction coefficient
- ϕ : Constant that is determined by the condition of oil film
- G : Non-dimensional characteristics value ($= \mu LU / Pr$)
- Pr : Compression force of packing (N)
- μ : Viscosity of fluid oil (Pa·s)
- L : Circumference length of the shaft (m)
- U : Speed (m/s)

Switching point G_c of the non-dimensional characteristics value where the fluid lubrication area shifts to the non-fluid lubrication area varies depending on the maximum contacting pressure gradient of the packing and the surface roughness of the rod and can be obtained by the formula (4) below.

$$G_c = \frac{9}{8\pi} \left(\frac{b}{p} \right) \left| \frac{dp}{dx} \right|_{\max} \left(\frac{Rz}{b} \right)^2 \dots\dots (4)$$

Where,

- b : Contacting width of the packing (m)
- p : Average contacting pressure of the packing (Pa)
- Rz : Maximum surface roughness of the rod (m)

Note: The surface roughness notation in this catalogue conforms to JIS B 0601 : 2001.

About compression force and extension force

The forces created by the rod or piston packings that are fitted on the mounting groove and in contact with the contacting surface (the surface of the rod or the inner surface of the cylinder) is called compression force and extension force, respectively.

The sealing ability of packings for reciprocal movement depends on the maximum contacting pressure gradient of the pushing and pulling stroke. Therefore, the values of the compression and extension force are not sufficient to judge the sealing ability of a packing for reciprocal movement.

B

SELECTING, TYPES, AND FEATURES

1. Types and Features of Hydraulic Seals for Reciprocating Application

- (1) Special packings for piston seals ———— 14~15
- (2) Special packings for rod seals ———— 16~17
- (3) Packings for both piston and rod seals ———— 18~19

2. Types and Features of Dust Seals

- (1) Dust seals for reciprocating application ———— 20~21
- (2) Dust seals for oscillating application ———— 22~23

3. Types and Features of Related Products for Hydraulic Equipment — 22~23

4. Application Range of Backup Rings ———— 24~25

5. Application Range of Wear Rings ———— 26~27

6. Flow chart for selecting the packing type

- (1) Rod seals ———— 28~29
- (2) Piston seals ———— 30~31
- (3) Dust seals ———— 32

The packings in this catalogue are neither designed nor manufactured to the use for medical application. Please do not use the products in this catalogue for the application physically contacting body fluid or biosystem, or as a transplant material to human body.

B. SELECTING, TYPES, AND FEATURES

Selecting material and the type most suitable for the operating condition is necessary to obtain optimal performance of the packing. In this chapter, we will describe the application range of seals and related products for hydraulic equipment, plus means of selection.

1. Types and Features of Hydraulic Seals for Reciprocating Application

(1) Special packings for piston seals

(Table B-1) Hydraulic Seals for Reciprocating Motion (Special packings for piston seals)

Type	Classification	NOK Type	Shape	Material	Main applicable fluid	Pressure (MPa)		Temperature (°C)		Speed (m/s)		
						Without backup ring	With backup ring	Without backup ring	With backup ring			
U Packing		ODI		Iron rubber (U801)	•General petroleum hydraulic fluid	Without backup ring	With backup ring	Without backup ring	With backup ring	0.03~1.0		
		OSI		Iron rubber (U801)		Without backup ring	With backup ring	Without backup ring	With backup ring			
		OUIS		Iron rubber		Without backup ring	With backup ring	Without backup ring	With backup ring			
		OUHR		Nitrile rubber		A505	Without backup ring	With backup ring	Without backup ring		With backup ring	
						A567	Without backup ring	With backup ring	Without backup ring		With backup ring	
OKH			Nitrile rubber	A566	Without backup ring	With backup ring	Without backup ring	With backup ring	0.008~1.0			
				A567	Without backup ring	With backup ring	Without backup ring	With backup ring				
Combination Seals		SPGO		① Rareflon (19YF)	•General petroleum hydraulic fluid oil •Water-glycol type hydraulic fluid oil •Oil-water emulsion type hydraulic fluid oil	Without backup ring	With backup ring	Without backup ring	With backup ring	0.005~1.5		
				② Nitrile rubber Fluoro rubber								
		SPG		① Rareflon (19YF)	•General petroleum hydraulic fluid oil •Water-glycol type hydraulic fluid oil •Oil-water emulsion type hydraulic fluid oil	Without backup ring	With backup ring	Without backup ring	With backup ring		Without backup ring	With backup ring
				② Nitrile rubber Fluoro rubber								
		SPGM		① Rareflon (55YF)	•General petroleum hydraulic fluid oil •Water-glycol type hydraulic fluid oil •Oil-water emulsion type hydraulic fluid oil	Without backup ring	With backup ring	Without backup ring	With backup ring		Without backup ring	With backup ring
				② Nitrile rubber Fluoro rubber								
		SPGN		① Polyamide resin (21NB) ② Nitrile rubber (A626)	•General petroleum hydraulic fluid oil •Water-glycol type hydraulic fluid oil •Oil-water emulsion type hydraulic fluid oil	Without backup ring	With backup ring	Without backup ring	With backup ring		Without backup ring	With backup ring
		SPGW		① Rareflon (19YF)	•General petroleum hydraulic fluid oil •Water-glycol type hydraulic fluid oil •Oil-water emulsion type hydraulic fluid oil	Without backup ring	With backup ring	Without backup ring	With backup ring		Without backup ring	With backup ring
② Polyamide resin (12NM or 80NP)												
③ Nitrile rubber Fluoro rubber Hydrogenated nitrile rubber												
SPGC		① Rareflon (31BF)	•General petroleum hydraulic fluid oil •Water-glycol type hydraulic fluid oil •Oil-water emulsion type hydraulic fluid oil	Without backup ring	With backup ring	Without backup ring	With backup ring	Without backup ring	With backup ring			
		② Nitrile rubber Fluoro rubber										
C Packing		CPI		Iron rubber (U801)	•General petroleum hydraulic fluid oil •Water-glycol type hydraulic fluid oil •Oil-water emulsion type hydraulic fluid oil	Without backup ring	With backup ring	Without backup ring	With backup ring	0.01~0.3		
		CPH		Nitrile rubber (A102) (A103) (A104) (A505)								

※ Temperature

- Nitrile rubber
- Nitrile rubber for low temperature
- Hydrogenated nitrile rubber
- Fluoro rubber
- Iron rubber
- Heat resistant Iron rubber

※ Pressure

- Without backup ring
- With backup ring

- Remark 1)** Depending on the size of extrusion gap, backup ring might be necessary. Refer to Fig.B-7 on page 25 and dimension table.
- Remark 2)** Applicable temperature ranges for packings are indicated by colors for each rubber material. (←See the figure to the left.)
- Remark 3)** When using the packing at a low speed, stick slip may occur depending on the cylinder structure or the using condition. In this case, consult NOK separately.
- Remark 4)** Some small diameter type cannot be installed with internal groove.
- Remark 5)** Items with a “—” mark in the dimension table column have unique specifications. Please consult NOK before ordering since there is no dimension description.
- Remark 6)** When using a special fluid, consult NOK.

In the following case, the combined effect of operating conditions must be carefully considered, therefore, please consult NOK.

- (1) In case of minimum pressure exceeding 3MPa at all times
- (2) In case of using packing at the border range of applicable temperature and pressure
- (3) In case of using packing with extremely short strokes (See examples of using with extremely short strokes on page 260 and 261.)
- (4) In case of using packing when speed of extending stroke of rod is greater than that of contracting stroke

Stroke (mm)	Sliding resistance	Installation with integrated groove <small>Remark 4</small>	Feature	Dimension table (page)
2,000 or below	Medium	No	•Designed for large section, applicable for wide pressure range	•Iron rubber U801, has excellent wear resistance and sealing ability. 59
	Medium	Yes	•Designed for smaller section, and able to be fitted into integrated groove	•Packings with a smaller section than ODI 67
	Medium	Yes		•Improvement has been made to prevent damages caused by back pressure. •Material with heat resistance, U641 is also available. 70
	Small	Yes		•Improvement against stick slip has been made. •The friction resistance is low and an improvement has been made to prevent damages caused by back pressure. •Nitrile rubber that has excellent low temperature resistance is employed and can be used with special low temperature hydraulic fluid oil (MIL H 5606E). 72
	Small	Yes		•Improvement against stick slip has been made. •Nitrile rubber that has excellent low temperature resistance is employed and can be used with special low temperature hydraulic fluid oil (MIL H 5606E). •It can be used with combination of Back-Up Ring BRL. (See the page 49) 74
	Very small	Yes	•Rareflon is used for sliding material. This packing has low frictional resistance, eliminating stick slip and assuring high wear resistance. •Installation space is saved because of bidirectional sealing ability by single packing.	•This is a standard type of combination seal for wide range of application. •This has the same performance as that of SPG. Installation space is saved because of JIS standard O ring. 77
	Very small	Yes		•This has the same performance as SPGO. This is used in case the service range of pressure 81
	Very small	Yes		•This has the same performance as SPGO. This is used in case the service range of pressure is wide and sliding speed is high. 86
	Very small	Yes		•This has the same performance as SPGO. This is used in case the service range of pressure is wide and sliding speed is high. 86
	Small	Yes	•Polyamide resin is used for sliding material. This packing has assuring high durability. •Installation space is saved because of bidirectional sealing ability by single packing.	•Suppresses venting leaks; provided with slit to allow hydraulic insertion at edge of seal ring. •Easy to attach using one point step cut on seal ring. •More compact than SPGW. 88
	Very small	Yes	•Rareflon is used for sliding material. This packing has low friction resistance eliminating stick slip and assuring high wear resistance. •Installation space is saved because of bidirectional sealing ability by single packing.	•This is a seal for high pressure operation with improved ability of SPG for oil scraping off. •Backup ring material of polyamide resin to improve the durability. 91
	Very small	Yes		•This packing can be fitted on to O ring groove (JIS B 2406 P series). •This has less sliding friction than O ring to improve the durability. •This can also be used for pneumatic equipment. 94
	Very small	Yes <small>Remark 4</small>		•This packing can be fitted on to O ring groove (JIS B 2406 P series). •This has less sliding friction than O ring to improve the durability. •This can also be used for pneumatic equipment. 94
	Small	No	•This packing is used for relatively low pressure operation.	•Packing material, Iron rubber U801 has excellent wear resistance and sealing ability. 98
Small	No	•Packing material, nitrile rubber, has excellent oil resistance and reduces sliding friction. 100		

1. Types and Features of Hydraulic Seals for Reciprocating Application

(2) Special packings for rod seals

(Table B-2) Hydraulic Seals for Reciprocating Motion (Special packings for rod seals)

Type	Classification	NOK Type	Shape	Material	Main applicable fluid	Pressure (MPa)		Temperature (°C)		Speed (m/s)
						Remark 1	Remark 2			
Special packings for rod seals	U Packing	IDI		Iron rubber (U801)	U801	•General petroleum hydraulic fluid	Without backup ring: 35, 70	With backup ring: 35, 70	Temperature: -35 to 100	0.03 ~ 1.0
		ISI		Iron rubber	U801 U641		Without backup ring: 30, 42	With backup ring: 30, 42	Temperature: -30 to 100, -10 to 110	
		IUIS		Iron rubber	U801 U641		Without backup ring: 30, 42	With backup ring: 30, 42	Temperature: -30 to 100, -10 to 110	
		IUH		Nitrile rubber	A505 A567 G928	•General petroleum hydraulic fluid oil •Water-glycol type hydraulic fluid oil •Oil-water emulsion type hydraulic fluid oil •Low temperature petroleum hydraulic fluid oil (General petroleum hydraulic fluid oil) Note: When using general petroleum-derived operating oil, we recommend A527.	Without backup ring: 14, 21	With backup ring: 14, 21	Temperature: -55 to 100, -25 to 80, -25 to 120	
		UNI		① Iron rubber (U801) ② Silicon rubber (S813) (Combination)	U801	•General petroleum hydraulic fluid •Low temperature petroleum hydraulic fluid oil	Without backup ring: 30, 42	With backup ring: 30, 42	Temperature: -45 to 100	
		SPNO		① Rareflon (19YF) ② Nitrile rubber Fluoro rubber (Combination)	A305 F201	•General petroleum hydraulic fluid oil •Water-glycol type hydraulic fluid oil •Oil-water emulsion type hydraulic fluid oil •General petroleum hydraulic fluid oil •Phosphate ester type hydraulic fluid oil	Without backup ring: 35	With backup ring: 35	Temperature: -30 to 100, -20 to 160	
	Combination Seals	SPN		① Rareflon (19YF) ② Nitrile rubber Fluoro rubber (Combination)	A980 F201	•General petroleum hydraulic fluid oil •Water-glycol type hydraulic fluid oil •Oil-water emulsion type hydraulic fluid oil •General petroleum hydraulic fluid oil •Phosphate ester type hydraulic fluid oil	Without backup ring: 35	With backup ring: 35	Temperature: -40 to 100, -20 to 160	0.005 ~ 1.5
		SPNS		① Rareflon (55YF) ② Nitrile rubber Fluoro rubber (Combination)	A305 F201	•General petroleum hydraulic fluid oil •Water-glycol type hydraulic fluid oil •Oil-water emulsion type hydraulic fluid oil •General petroleum hydraulic fluid oil •Phosphate ester type hydraulic fluid oil	Without backup ring: 35	With backup ring: 35	Temperature: -30 to 100, -20 to 160	
		SPNC		① Rareflon (31BF) ② Nitrile rubber Fluoro rubber (Combination)	A305 F201	•General petroleum hydraulic fluid oil •Water-glycol type hydraulic fluid oil •Oil-water emulsion type hydraulic fluid oil •General petroleum hydraulic fluid oil •Phosphate ester type hydraulic fluid oil	Without backup ring: 2	With backup ring: 2	Temperature: -30 to 100, -20 to 160	

※ Temperature

- Nitrile rubber
- Nitrile rubber for low temperature
- Hydrogenated nitrile rubber
- Fluoro rubber
- Iron rubber
- Heat resistant Iron rubber

※ Pressure

- Without backup ring
- With backup ring

- Remark 1)** Depending on the size of extrusion gap, backup ring might be necessary. Refer to Fig.B-7 on page 25 and dimension table.
- Remark 2)** Applicable temperature ranges for packings are indicated by colors for each rubber material. (←See the figure to the left.)
- Remark 3)** When using the packing at a low speed, stick slip may occur depending on the cylinder structure or the using condition. In this case, consult NOK separately.
- Remark 4)** Some small diameter type cannot be installed with internal groove.
- Remark 5)** Items with a “—” mark in the dimension table column have unique specifications. Please consult NOK before ordering since there is no dimension description.
- Remark 6)** When using a special fluid, consult NOK.

In the following case, the combined effect of operating conditions must be carefully considered, therefore, please consult NOK.

- (1) In case of minimum pressure exceeding 3MPa at all times
- (2) In case of using packing at the border range of applicable temperature and pressure
- (3) In case of using packing with extremely short strokes (See examples of using with extremely short strokes on page 260 and 261.)
- (4) In case of using packing when speed of extending stroke of rod is greater than that of contracting stroke

Stroke (mm)	Sliding resistance	Installation with integrated groove <small>Remark 4</small>	Feature	Dimension table (page)
2,000 or below	Medium	No	•Packings with large section can be used for wide range of pressure.	•Packing material, Iron rubber U801 has excellent wear resistance and sealing ability. 103
	Medium	Yes	•Packings with small section can be fitted in integrated groove.	•Packings with a smaller section of IDI. •Material with heat resistance, U641 is also available. 111
	Medium	Yes		•Improvement is made to prevent damage caused by back pressure. •Heat resistant U641 is also available. 114
	Small	Yes <small>Remark 4</small>	•This packing is used for low temperature and high pressure operations.	•Improvement is made to prevent the damages caused by back pressure. •Material with excellent cold resistance, nitrile rubber A567 is also available. This can be used for special low temperature oil (MIL H 5606E). •Heat resistant, wear resistant hydrogenated nitrile rubber (H-NBR) G928 material also available. 117
	Medium	No		•Iron rubber is used for material and back ring can prevent the lack of interference at low temperature. 120
	Very small	Yes <small>Remark 4</small>	•Rareflon is used for sliding material. This packing has low frictional resistance, eliminating stick slip and assuring high wear resistance.	•This is a standard type of combination seal and can be used for wide range of operation. 123
	Very small	Yes <small>Remark 4</small>		•This has the same performance as SPNO. This is used in case the service range of pressure is wide and sliding speed is high. 126
	Very small	Yes <small>Remark 4</small>	•Rareflon is used for sliding material. This packing has low friction resistance eliminating stick slip and assuring high wear resistance.	•Compared to SPNO and SPN, the product is excellent in the sealing performance. 129
	Very small	No		•This packing can be fitted on to O ring groove (JIS B 2406 P series). •This has less sliding friction than O ring to improve the durability. •This can also be used for pneumatic equipment. 133

1. Types and Features of Hydraulic Seals for Reciprocating Application

(3) Packings for both piston and rod seals

(Table B-3) Hydraulic Seals for Reciprocating Motion (Packings for both piston and rod seals)

Type	Classification	NOK Type	Shape	Material	Main applicable fluid	Pressure (MPa)		Temperature (°C)		Speed (m/s)
						Remark 1	Remark 2			
Packings for both piston and rod seals	U Packing	UPI		Iron rubber (U801)	U801	General petroleum hydraulic fluid	30, 35	-35, 100	0.03 ~ 1.0	
		USI		Iron rubber (U593)	U593		21	-35, 80		
		UPH		Nitrile rubber Fluoro rubber	A505	General petroleum hydraulic fluid oil Water-glycol type hydraulic fluid oil Oil-water emulsion type hydraulic fluid oil	15, 32	-25, 100		
					F357	General petroleum hydraulic fluid oil Phosphate ester type hydraulic fluid oil	-10, 150			
	USH		Nitrile rubber Fluoro rubber	A505	General petroleum hydraulic fluid oil Water-glycol type hydraulic fluid oil Oil-water emulsion type hydraulic fluid oil	14, 21	-25, 100			
				A567	Low temperature petroleum hydraulic fluid oil (General petroleum hydraulic fluid oil) Note: When using general petroleum-derived operating oil, we recommend A527.			-55, 80		
				F357	General petroleum hydraulic fluid oil Phosphate ester type hydraulic fluid oil			-10, 150		
	V Packing	V99F		Fabric reinforced nitrile rubber	21AG	General petroleum hydraulic fluid oil Water-glycol type hydraulic fluid oil Oil-water emulsion type hydraulic fluid oil Water	4, 16, 30 (5 sheet)	-25, 100	0.05 ~ 1.0	
		V96H		Nitrile rubber Fluoro rubber	A505	General petroleum hydraulic fluid oil Water-glycol type hydraulic fluid oil Oil-water emulsion type hydraulic fluid oil Water	4, 8, 30 (5 sheet)	-25, 100	0.05 ~ 0.5	
	F357				General petroleum hydraulic fluid oil Phosphate ester type hydraulic fluid oil Agricultural chemicals	-10, 150				

※ Temperature

- Nitrile rubber
- Nitrile rubber for low temperature
- Fluoro rubber
- Iron rubber
- Heat resistant Iron rubber

※ Pressure

- Without backup ring
- With backup ring

- Remark 1)** Depending on the size of extrusion gap, backup ring might be necessary. Refer to Fig.B-7 on page 25 and dimension table.
- Remark 2)** Applicable temperature ranges for packings are indicated by colors for each rubber material. (←See the figure to the left.)
- Remark 3)** When using the packing at a low speed, stick slip may occur depending on the cylinder structure or the using condition. In this case, consult NOK separately.
- Remark 4)** Some small diameter type cannot be installed with internal groove.
- Remark 5)** Items with a “—” mark in the dimension table column have unique specifications. Please consult NOK before ordering since there is no dimension description.
- Remark 6)** When using a special fluid, consult NOK.

In the following case, the combined effect of operating conditions must be carefully considered, therefore, please consult NOK.

- (1) In case of minimum pressure exceeding 3MPa at all times
- (2) In case of using packing at the border range of applicable temperature and pressure
- (3) In case of using packing with extremely short strokes (See examples of using with extremely short strokes on page 260 and 261.)
- (4) In case of using packing when speed of extending stroke of rod is greater than that of contracting stroke

Stroke (mm)	Sliding resistance	Remark 4) Installation with integrated groove	Feature	Dimension table(page)	
2,000 or below	Medium	No	<ul style="list-style-type: none"> •This can be used both for piston and rod seals. •This packing has large section and can be used for wide range of operations. 	<ul style="list-style-type: none"> •Material, Iron rubber U801, has excellent wear resistance and sealing ability. 	137
	Small	Remark 4) Yes	<ul style="list-style-type: none"> •This can be used both for piston and rod seals. •This packing has small section and can be fitted in integrated groove. 	<ul style="list-style-type: none"> •This is a type with smaller section of UPI. •Improvement has been made to prevent damages caused by back pressure. 	143
	Medium	No	<ul style="list-style-type: none"> •This can be used both for piston and rod seals. •This packing has large section and can be used for wide range of operations. 	<ul style="list-style-type: none"> •Nitrile rubber and fluoro rubber are available for material to assure wide range of operating temperature. •Wide variation of size is available. 	147
	Small	Remark 4) Yes	<ul style="list-style-type: none"> •This can be used both for piston and rod seals. •This packing has small section and can be fitted in integrated groove. 	<ul style="list-style-type: none"> •This is a type with a smaller section of UPH. 	155
	Large	No	<ul style="list-style-type: none"> •This can be used for severe operating conditions by plying packings according to the operation pressure. 	<ul style="list-style-type: none"> •This is a standard type of V packing. 	159
	Large	No	<ul style="list-style-type: none"> •Installation width is larger than U packings. Less sealing ability than U packings. 	<ul style="list-style-type: none"> •Compared with V99F, this is selected in case the sealing performance is more important. 	165
					—

2. Types and Features of Dust Seals

(1) Dust seals for reciprocating motion





The main feature of a dust seal is to seal outside dust. In addition, a sealing system using a dust seal, combined with rod packings and a buffer ring, can prevent oil film being scraped out.

Specific performance will vary depending upon the type of dust seal. Therefore, if maintaining oil film on a cylinder is more important, please consult NOK.

※ Temperature

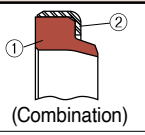
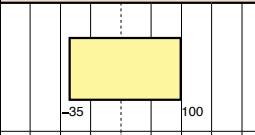
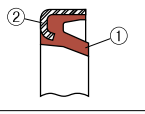
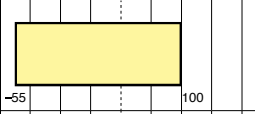
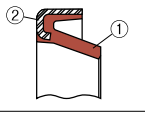
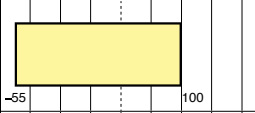
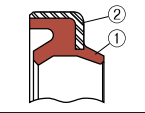
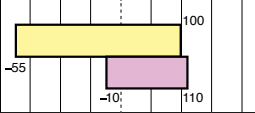
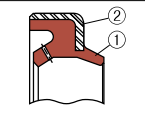
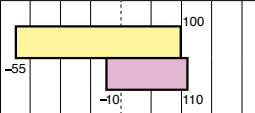
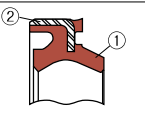
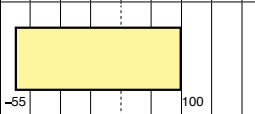
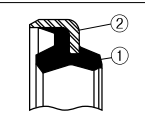
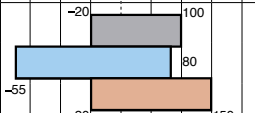
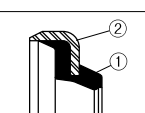
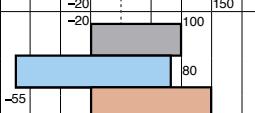
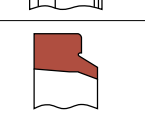
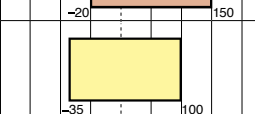
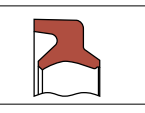
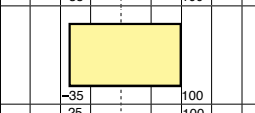
- Nitrile rubber
- Nitrile rubber for low temperature
- Fluoro rubber
- Iron rubber
- Heat resistant Iron rubber

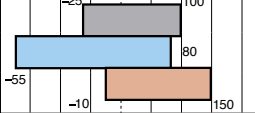
〈Table B-4〉 Dust seals for reciprocating motion

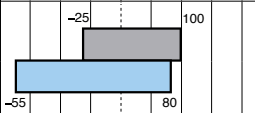
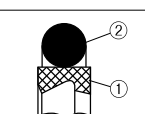
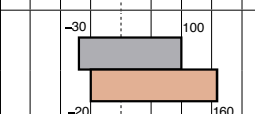
Type	NOK Type	Shape	Material	Main applicable fluid	Pressure (MPa) <small>Remark 1)</small>		Dust proof performance	Oil scraping proof performance
					-50 -40 -20 0 100 200			
Dust seals	DKI	 (Combination)	① Iron rubber (U801) ② Cold rolled steel plate sheet (SPCC)	U801	• Outside dust		◎	Medium
	DWI		① Iron rubber (U801) ② Cold rolled steel plate sheet (SPCC)	U801			◎	Small
	DWIR		① Iron rubber (U801) ② Cold rolled steel plate sheet (SPCC)	U801			○	Very small
	DKBI		① Iron rubber (U801) ② Cold rolled steel plate sheet (SPCC)	U801 U641			◎	Very small
	DKBI3		① Iron rubber (U801) ② Cold rolled steel plate sheet (SPCC)	U801 U641			◎	Very small
	DKBZ		① Iron rubber (U801) ② Cold rolled steel plate sheet (SPCC)	U801			◎	Very small
	DKB		① Nitrile rubber Fluoro rubber ② Cold rolled steel plate sheet (SPCC)	A795 A980 F975			○	Very small
	DKH		① Nitrile rubber Fluoro rubber ② Cold rolled steel plate sheet (SPCC)	A104 A795 A980 F975			○	Medium
	DSI		Iron rubber (U801)	U801			○	Medium
	LBI		Iron rubber (U593)	U593			○	Small
	LBH		Nitrile rubber Fluoro rubber	A505 A567 F357			○	Small
	LBHK		Nitrile rubber	A505 A567			○	Small
	DSPB		① Rareflon (11YF) ② Nitrile rubber Fluoro rubber	A305 F201			○	Small

Remark 1) Applicable temperature ranges for dust seals are indicated by colors for each rubber material. (←See the figure to the left.)

Remark 2) When using the packing at a low speed, stick slip may occur depending on the cylinder structure or the using condition. In this case, consult NOK separately.

Remark 3) Some small diameter type cannot be installed with internal groove.

Remark 4) Items with a “—” mark in the dimension table column have unique specifications. Please consult NOK before ordering since there is no dimension description.

	Requirement of stopper	Installation with integrated groove	Feature	Dimension table (page)
	No	No	•This is a standard type of dust seal of Iron rubber with high dust proof performance.	171
	No	No	•Employing Iron rubber as material, this seal serves under severe dust conditions such as construction equipment.	174
	No	No	•Employing Iron rubber as material, this has the same performance as DWI, excellent in preventing of oil scraping out and in follow-ability to the eccentricity.	176
	No	No	•Employing Iron rubber as material, this is a double-lip dust seal to prevent oil scraping off.	178
	Yes	No	•Small one point hole in DKBI oil lip allows pressure build-up to escape and prevents loss or damage to the dust seal.	180
	Yes	No	•Thanks to the improved dust resistance of the DKBI, the dust seal provides a better balance between dust resistance and oil scraping performance.	182
	Yes	No	•Employing nitrile rubber as material, this is a double-lip dust seal to prevent oil scraping off.	184 — —
	No	No	•Employing nitrile rubber as material, this is a single-lip dust seal. •Material A795: for diameter ø300 or below A104: for diameter over ø300	186 — —
	—	Yes	•Employing Iron rubber as material, this is a single-lip all rubber dust seal.	189
	—	Yes	•This product uses the iron rubber as the material, and is a double-lip rubber-only dust seal aiming at preventing scrape-out of oil.	192
	—	Yes	•This is a double-lip all rubber dust seal to prevent oil scraping off. •Nitrile rubber and fluoro rubber are available as material for wide range of operating temperature.	195 — 195
	—	Yes	•This product has a sub-lip in the dust lip, is effective in preventing water from entering, and can be used both indoor and outdoor. •This product has a notch in the oil lip and lower back of the packing, and is excellent in accumulation pressure prevention characteristics.	198
	—	Yes <small>Remark 3)</small>	•Prevents entry of dust, protects equipment, and maintain, sealing performance of packings. •Rareflon is used for sliding material. This packing has low frictional resistance, eliminating stick slip.	201 —

2. Types and Features of Dust Seals

(2) Dust seals for oscillating application

Dust seals for oscillating motion are mainly used for hinge pin and bush parts. In contrast to dust seals for reciprocating motion, the shape of lip is specially designed to reduce torque and have a relief effect by rear-side greasing, this assures good performance in severe dust conditions.

<Table B-5> Dust seals for oscillating and rotating movement

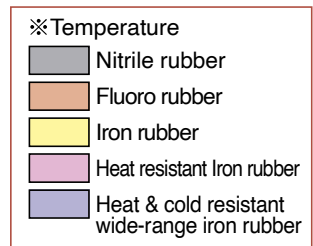

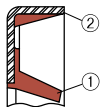
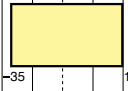
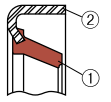







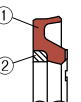
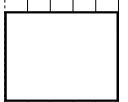
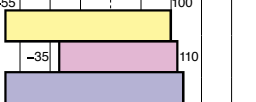
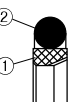
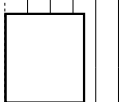
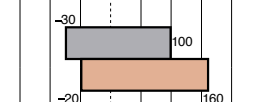

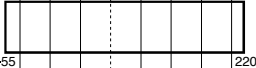

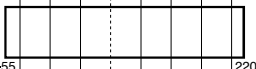

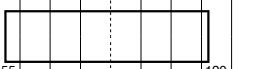

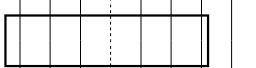

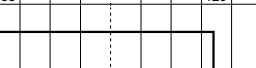

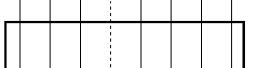
Type	Classification	NOK Type	Shape	Material	Main applicable fluid	Pressure (MPa) ^{Remark 1)}	Temperature (°C) ^{Remark 2)}
Dust seals for oscillating application	Hinge pin dust seals	DLI		① Iron rubber ② Cold rolled steel plate sheet (SPCC)	•Outside dust	-	
		DLI2		① Iron rubber (U451) ② Cold rolled steel plate sheet (SPCC)			

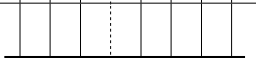
3. Types and Features of Related Products for Hydraulic Equipment

Selecting the right combination of packings and related products for the specific operating conditions will insure proper sealing effectiveness.

<Table B-6> Relating products for reciprocal movement

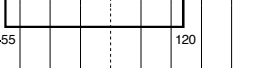
Type	Classification	NOK Type	Shape	Material	Main applicable fluid	Pressure (MPa) ^{Remark 1)}	Temperature (°C) ^{Remark 2)}				
Special packing for rod seals	Buffer ring	HBV		① Iron rubber ② Polyamide resin (12NM or 80NP)	•General petroleum hydraulic fluid						
		HBTS		① Rareflon (55YF) ② Nitrile rubber Fluoro rubber				•General petroleum hydraulic fluid oil •Water-glycol type hydraulic fluid oil •Oil-water emulsion type hydraulic fluid oil •General petroleum hydraulic fluid oil •Phosphate ester type hydraulic fluid oil			
Relating products for reciprocal movement	Wear rings	RYT		Rareflon (05ZF)	•General petroleum hydraulic fluid oil •Water-glycol type hydraulic fluid oil •Oil-water emulsion type hydraulic fluid oil •Phosphate ester type hydraulic fluid oil •Low temperature petroleum hydraulic fluid oil	-					
		WRT2		Rareflon (08GF)							
		WR		Fabric reinforced phenolic resin							
		WRR		Fabric reinforced phenolic resin							
		WR		Resin fiber polyester (88RS)							
	Contami seals	KZT		Rareflon (05ZF)							
	Backup ring	BRT2		Rareflon (19YF)				•General petroleum hydraulic fluid oil •Phosphate ester type hydraulic fluid oil •Low temperature petroleum hydraulic fluid oil	-		
		BRT3									no cut endless type
		BRN2		Polyamide resin (80NP)							
		BRN3									
BRL		Polyamide resin (63NP)									

- Remark 1)** Permissible temperature ranges for dust seals are indicated by colors for each rubber material. (←See the figure to the left.)
- Remark 2)** When using the packing at a low speed, stick slip may occur depending on the cylinder structure or the using condition. In this case, consult NOK separately.
- Remark 3)** Combination Backup Ring Part Numbers are listed on each applicable packing's dimension table.

In the following case, the combined effect of operating conditions must be carefully considered, therefore, please consult NOK.

- (1) In case of minimum pressure exceeding 3MPa at all times
- (2) In case of using packing at the border range of applicable temperature and pressure
- (3) In case of using packing with extremely short strokes (See examples of using with extremely short strokes on page 260 and 261.)

Speed (m/s)	Feature	Dimension table (page)
—	<ul style="list-style-type: none"> This is a dust seal for oscillating and rotating movement for hinge pin and bush. This can be used under severe dust conditions to improve the durability of the equipment. 	204
—	<ul style="list-style-type: none"> Relief effect makes easy to drain used grease when filling up new grease. This is mainly used to the housing diameter exceeding $\phi 160$. 	206

Speed (m/s)	Feature	Dimension table (page)	
0.03 ~1.0	<ul style="list-style-type: none"> This is used in combination with rod packing to absorb the impact and fluctuating pressure at high load, to isolate high temperature fluid, and to improve the durability of the packing. 	208	
0.005 ~1.5	<ul style="list-style-type: none"> This has the same function as that of HBY. This has small friction resistance and suits for high speed, extremely short stroke operation. A slit on the tapered surface (non-sliding surface) can leak back pressure. 	211	
0.005 ~1.5	<ul style="list-style-type: none"> Supplied in hoop (10m/roll) enabling to be cut according to the cylinder diameter. Rareflon is used for material. This wear ring has low frictional resistance eliminating stick slip. 	214	
	<ul style="list-style-type: none"> Rareflon is used for sliding material. This packing has low frictional resistance, eliminating stick slip. 	—	
0.005 ~1.0	<ul style="list-style-type: none"> This is used as bearing of piston to prevent its scoring or eccentricity and to improve the durability of the packings. 	217	
	<ul style="list-style-type: none"> Excellent compression proof and wear resistance because of its fabric reinforced laminated phenolic resin material. One bias-cut is provided on the ring. 	—	
	<ul style="list-style-type: none"> This is used as bearing of rod to prevent its scoring or eccentricity and to improve the durability of the packings. 	—	
0.005 ~1.5	<ul style="list-style-type: none"> This is used as bearing of piston & rod to prevent its scoring or eccentricity and to improve the durability of the packings. 	221	
	<ul style="list-style-type: none"> Resin fiber polyester material is used to boost impact strength and prevent cracking. The excellent compression characteristics of this material also enable a more compact design. Resin fiber polyester has low bending strength and is easy to assemble, making it suitable for thin rods. 	221	
0.005 ~1.5	<ul style="list-style-type: none"> This is used in combination with piston packings and wear rings to prevent damages of packings caused by foreign object in oil within the cylinder and to improve the durability of packings. When used in combination with rod packing and metal bush, damages of the rod can be prevented because of the foreign object submerging function of rareflon. One point cut is provided and oil pressure bypass slot is also provided to prevent pressure accumulation. 	224	
—	<ul style="list-style-type: none"> This is used to prevent extrusion of packings and to improve the pressure resistance of the packings. 	<ul style="list-style-type: none"> Standard cutting shape is bias-cut (BRT2). If there are no problem for installation, no cut endless type (BRT3) can be also used. 	Remark 3) —
—	<ul style="list-style-type: none"> This is used to prevent extrusion of packings and to improve the pressure resistance of the packings. 	<ul style="list-style-type: none"> Standard cutting shape is bias-cut (BRN2). If there are no problem for installation, no cut endless type (BRN3) can be also used. 	Remark 3) —
—	<ul style="list-style-type: none"> This is a backup ring that also serves as a wear ring. It can be used as the OKH type wear ring and as an OKH backup ring. 	<ul style="list-style-type: none"> This is a backup ring that also serves as a wear ring. It can be used as the OKH type wear ring and as an OKH backup ring. 	Remark 3) —

4. Application Range of Backup Ring

(1) The role of backup ring

If the extrusion gap is too large for the operating pressure of the packing, the heels of the packing may be damaged by extrusion (Fig. B-1).

In such case, a backup ring is necessary to prevent extrusion of the packing and to improve the durability (Fig. B-2).

Fig. B-7 on page 25 shows the relationship between operating pressure and extrusion gap.

(2) Mechanism preventing extrusion

When the pressure is loaded, the backup ring is compressed and deformed to reduce the gap ($g' \rightarrow 0$), which prevents the extrusion of the packing heel (Fig. B-3 and 4).

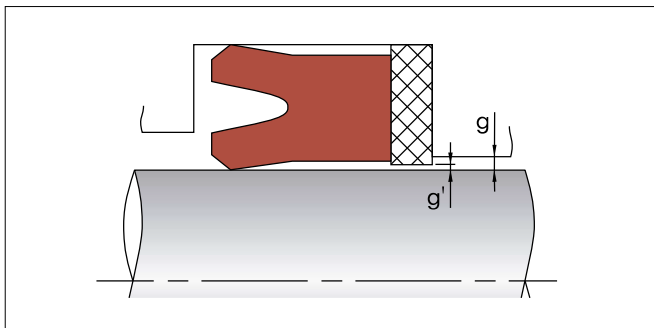

<Fig. B-3>

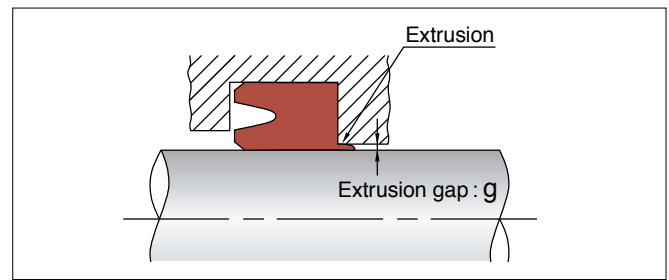

<Fig. B-1>

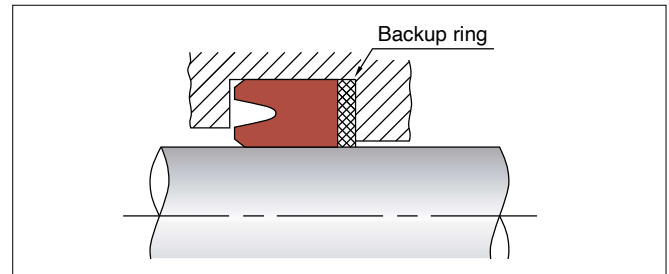

<Fig. B-2>

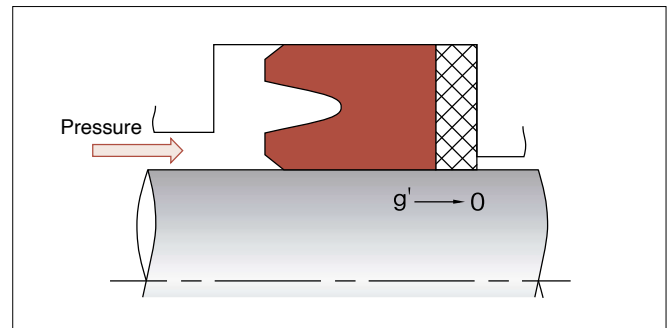

<Fig. B-4>

(3) Application Range of Backup Ring

Material characteristics required for a backup ring are easy compression deformation and extrusion resistance under working pressure. Friction resistance and low-friction characteristics are also important because a compressed and deformed backup ring moves in contact with the sliding surface. Considering these requirements, NOK made available two engineered plastic materials; polytetra-

fluoro-ethylene (PTFE) resin (NOK rareflon) and polyamide resin. Rareflon is mainly used, while polyamide resin with high rigidity against deformation is used in high pressure conditions. Table B-7 shows guidelines for material selection and Table B-8 on page 25 shows the sign and characteristics of these materials and applicable packing type signs.

<Table B-7> Guideline for backup ring material selection

Packing material	Pressure (MPa)	0	14	32	35	70
	Iron rubber		Rareflon		Polyamide resin	
Nitrile, fluororubber, etc.		Rareflon		※ Combination of NOK rareflon and polyamide resin (Fig. B-5) ※ Thin rareflon sheet (see Fig. B-6): Effective in adapting to the current groove or as a measure against abrasion (wear) in the heel section.		

Remark 1) This table is a guideline for backup ring material selection. In selecting a packing, conditions other than pressure, such as extrusion gap, temperature, and packing shape, should also be considered.

Remark 2) Some of the packing profiles, especially small sizes, may not fit in the appropriate groove.

Remark 3) The dimensions of the polyamide resin may change due to moisture adsorption. If moisture-proof packaging is necessary, consult NOK.

Remark 4) When using larger diameter (inner diameter (d) exceeding the classification 300mm), consult NOK.

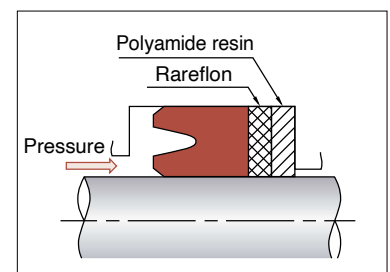

<Fig. B-5>

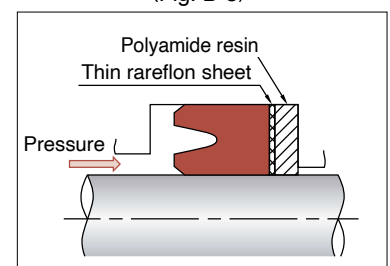

<Fig. B-6> An example of using the Thin rareflon sheet

〈Table B-8〉 Material code and characteristics of backup ring

Material	NOK material code	Features	Durability	Applicable packing type sign
Rareflon	10FF	Pure PTFE. This material is excellent in heat resistance, cold resistance, and chemical resistance		OUHR UPH, USH IUH
	31BF	Low frictional resistance material with improved frictional and creep resistance against pure PTFE		
	34WF	Material boasts pure PTFE characteristics with enhanced wear resistance and creep resistance.		
	19YF	Standard material with high resistance against extrusion and friction under high pressure operation		
	49YF	Special material with improved extrusion resistance of 19YF		
Polyamide resin	80NP	Material with high resistance against extrusion and friction for high pressure. Its machining manufacturing process makes large diameter seals available		ODI, OSI, OUIS, UPI, USI IDI, ISI, IUIS, UNI
	12NM	Material for injection molding having the same performance as 80NP with smaller dimension changes by water absorption		

※ The dimensions of the polyamide resin may change due to moisture adsorption. If the moisture-proof packaging is necessary, consult NOK separately.

(4) Extrusion limit

Fig. B-7 is extrusion limit curves prescribed by JFPS1003 showing extrusions of rubber material for packings. This figure also shows the extrusion limit curves of NOK backup ring materials. The extrusion value of packings and backup rings varies depending

on the temperature, pressure, and operating time. Therefore, please refer to the extrusion limit curves on dimension tables of each type for proper application.

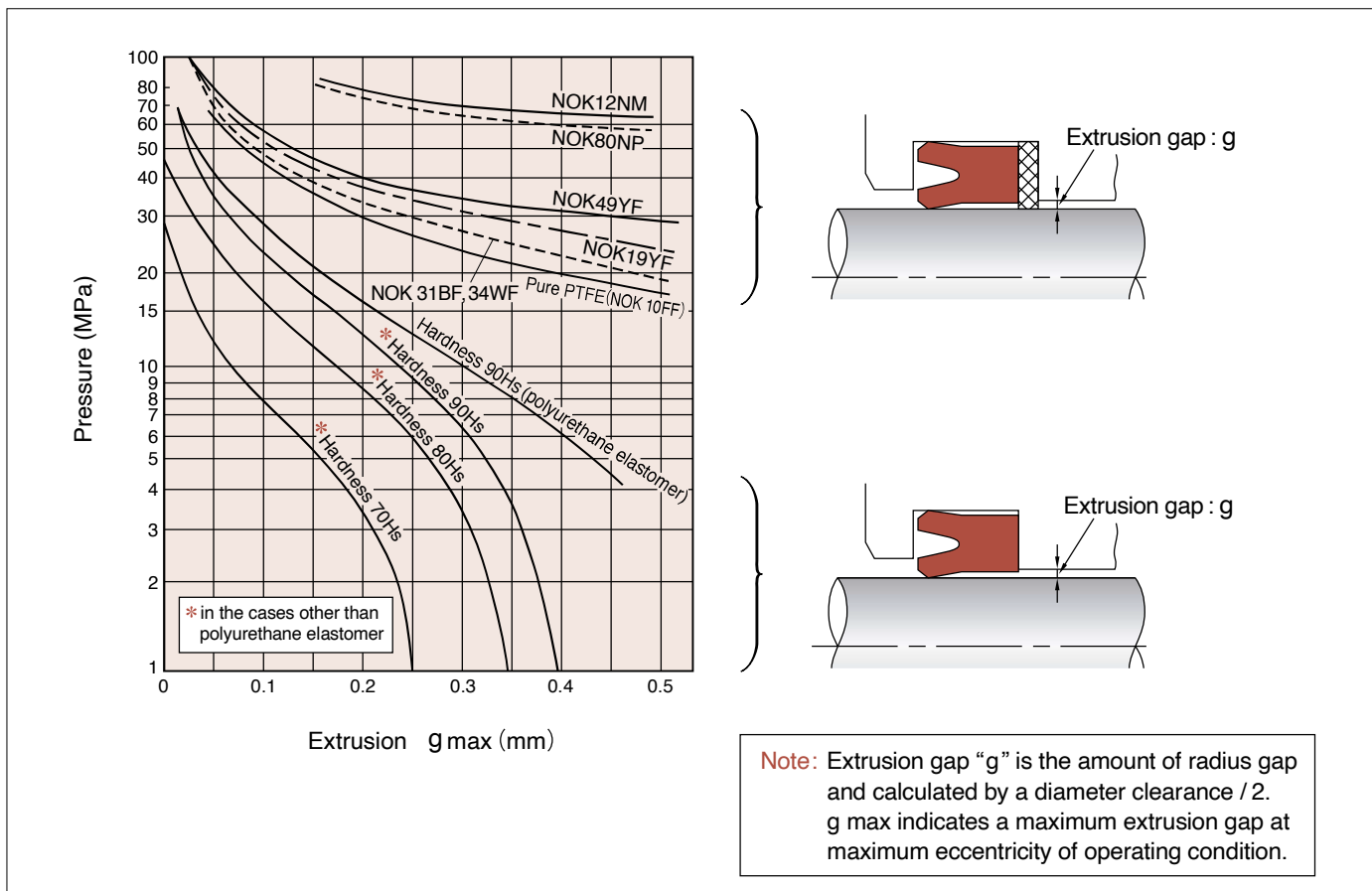

〈Fig. B-7〉 Extrusion limit curves

※ Extrusion limit may vary depending on the temperature, pressure, and operating time. Therefore, please consult NOK when using under excessive high temperature and high pressure condition for long term use.

5. Application Range of Wear Ring

(1) The role of wear rings

Wear rings are used as bearings on a piston to prevent scuffing the piston and cylinder, minimize the eccentricity, and improve the durability of packings.

(2) Selecting the wear rings

Select the shape and material of a wear ring according to the operating condition. For low speed and heavy load operations such as construction equipment, type WR with fabric reinforced phenolic

resin (NOK 12RS·15RS)·resin fiber polyester (NOK 88RS) is recommended.

This material has excellent characteristics against compression load. For high speed and light load operations or operations where stick slip may be possible, type RYT of rareflon (NOK 05ZF) or type WRT (NOK 88RS) is recommended. This material has excellent characteristics against friction and wear. **Table B-9** shows the characteristics and application range of each wear ring type.

<Table B-9> Characteristics and application range of wear ring

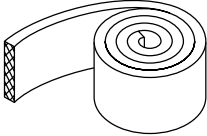
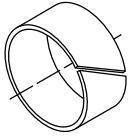
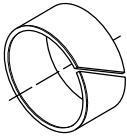
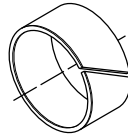
Type	RYT	WRT2	WR·WRR	WR
Shape				
Material (NOK sign)	Rareflon (rareflon 05ZF)	Rareflon (rareflon 08GF)	Fabric reinforced phenolic resin (12RS, 15RS)	Resin fiber polyester (NOK 88RS)
Characteristics	<ul style="list-style-type: none"> ●Low friction and stick slip suppresses wear ring ●Excellent wear resistance under high speed and light load operation ●Supplied in hoop (10m/roll) enabling to be cut according to the cylinder diameter 	<ul style="list-style-type: none"> ●Low friction and stick slip suppresses wear ring ●Excellent wear resistance under high speed and light load operation ●Thin rareflon sheet has a bias cut at one location and any required size for diameter and width is available 	<ul style="list-style-type: none"> ●NOK standard wear ring having excellent compression resistance characteristics ●Excellent wear resistance under low speed and heavy load operation ●Wide range of diameter and width size are available. Each piece has one point biascut. (Sizes other than those on the dimension table are available.) ●Wear rings of rareflon (WRT) are also available 	<ul style="list-style-type: none"> ●Wear ring with high impact strength and lateral load resistance ●Suitable for pistons and rods ●Each piece has one point biascut. (Sizes other than those on the dimension table are available.)
Allowable temperature range	-55 ~ 220°C		-55 ~ 120°C	-60 ~ 130°C

(3) Dimension Set up of Wear Rings

RYT (NOK 05ZF) and WR (NOK 12RS) of various diameter sizes and width sizes are prepared so that the customer can select them according to cylinder diameter and groove size. For details, see the dimension table on pages 214 to 222. Consult NOK for WRT2 (NOK 08GF) and WR (NOK 15RS) manufacturing. Set width size "h", using the following calculation expression.

$$h_{\min} \geq \frac{F \cdot S_0}{\sigma \cdot D \cdot \pi \cdot (1/3)} + 2C \dots\dots(a)$$

- h min : Minimum width size of wear ring (mm)
- F : Load charged on wear ring (N)
- S₀ : Safety coefficient
- σ : Allowable surface pressure of wear ring material (MPa)
- D : Inner diameter of cylinder tube (mm)
- C : Chamfer width of wear ring (mm)
(12RS·15RS : C=0.8, 05ZF·08GF : C=0)

Allowable Surface Pressure of Wear Ring Material : σ

Fig. B-8 shows the allowable surface pressure of wear ring material under the oil lubrication condition. The allowable surface pressure varies with sliding speed.

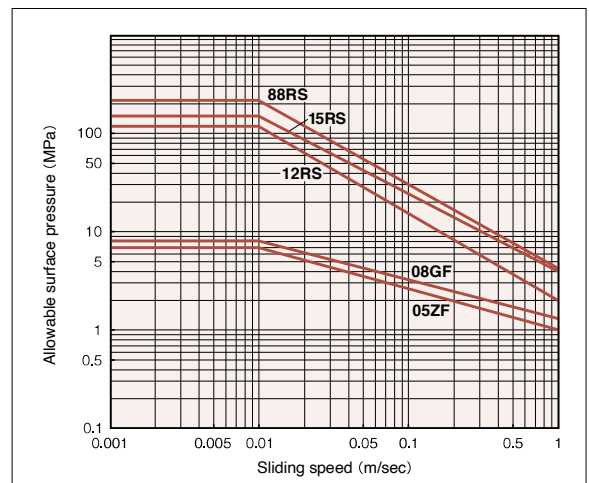

<Fig. B-8> Sliding speed and wear ring material's allowable surface pressure

Load that is Applied to Wear Ring : F

The load that is applied to wear rings is based on the principle of leverage and is calculated using the following calculation expression.

① When lateral load exists

〈Piston〉

$$W \times L_2 = F_1 \times L_1$$

$$F_1 = W \times \frac{L_2}{L_1} \dots\dots(b)$$

〈Rod〉

$$F_2 = F_1 + W$$

$$F_2 = W \times \frac{L_1 + L_2}{L_1} \dots\dots(c)$$

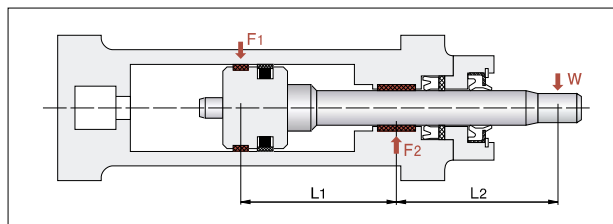

〈Fig. B-9〉

② When lateral load does not exist

〈For both piston and rod〉

$$F^* = (\text{Piston's weight} + \text{rod's weight}) + \frac{1}{200} \times \frac{\pi \cdot D^2}{4} \times P_{\text{max}} \dots(d)$$

$$* F = F_1 = F_2$$

- W : Lateral load (N)
- L1, L2 : Distance (mm)
- D : Inner diameter of cylinder tube (mm)
- P max : Maximum pressure (MPa)
- F1 : Load that is applied to wear ring for piston (N)
- F2 : Load that is applied to wear ring for rod (N)

Safety Rate : S₀

① When lateral load exists

- S₀ { When impact lateral load does not exist : 1.5
- { When impact lateral load exists : 4

② When lateral load does not exist

$$S_0 = 1$$

Set width size "h", using the calculation expression described in (3).

$$L = \pi \cdot (D - t) - S$$

Calculate length "L" which is cut according to the inner diameter of the cylinder, using the following calculation expression:

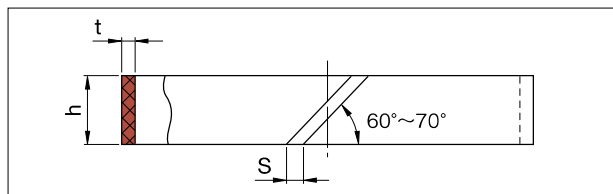

〈Fig. B-10〉

- D : Inner diameter of cylinder tube (mm)
- t : Thickness of wear ring (mm)
- S : Clearance of wear ring (mm)

Note: For t and S, see the dimension table on page 214.

Example Calculation Example of Width Size of Wear Ring

Calculate the width size of wear ring (type: WR, material: 12RS) for the piston, based on the following using condition.

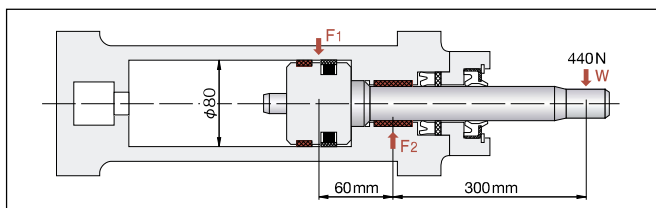

〈Conditions〉

Item	Description
Maximum lateral load (W)	440 N
Maximum rod length (L2)	300 mm
Minimum bearing clearance (L1)	60 mm
Speed (V)	0.3 m/s
Cylinder tube inner diameter (D)	φ80
Impact lateral load	Yes

Step 1 What is the load applied to the wear ring?

First, calculate load F1 for the wear ring. Since the above condition includes lateral load, calculate the load that is applied to the wear ring, using expression (b).

$$F_1 = W \times \frac{L_2}{L_1} = 440 \times \frac{300}{60} = 2200 \text{ (N)}$$

Step 2 What is the allowable surface pressure of wear ring material?

The line drawing in Fig. B-8 shows that the allowable surface pressure of 12RS material at V=0.3 m/s is 6 MPa.

Step 3 What is the dimension of wear ring width?

Assign the values obtained in the above steps (1) and (2) to the expression (a) that calculates width size "h" (minimum). Also, when impact lateral load exists, set the safety rate S₀ to 4.

$$h_{\text{min}} \geq \frac{2200 \times 4}{6 \times 80 \times \pi \times (1/3)} + 1.6$$

$$= 19.1 \text{ mm}$$

From the above, 20 mm is obtained for the width size of wear ring for the piston under the above conditions.

Note: When setting width size, round up the value after the decimal point.

6. Flow Chart for Selecting the Packing Type

NOK provides a wide range of seals in various conditions. A selection flow chart is shown to determine the optimum seal.

1. After selecting the packing type, check if the working temperature, the speed, and the stroke are in the applicable range for each seal, by referring to pages 14 and 19.

(1) Rod seals (Fig. B-11)

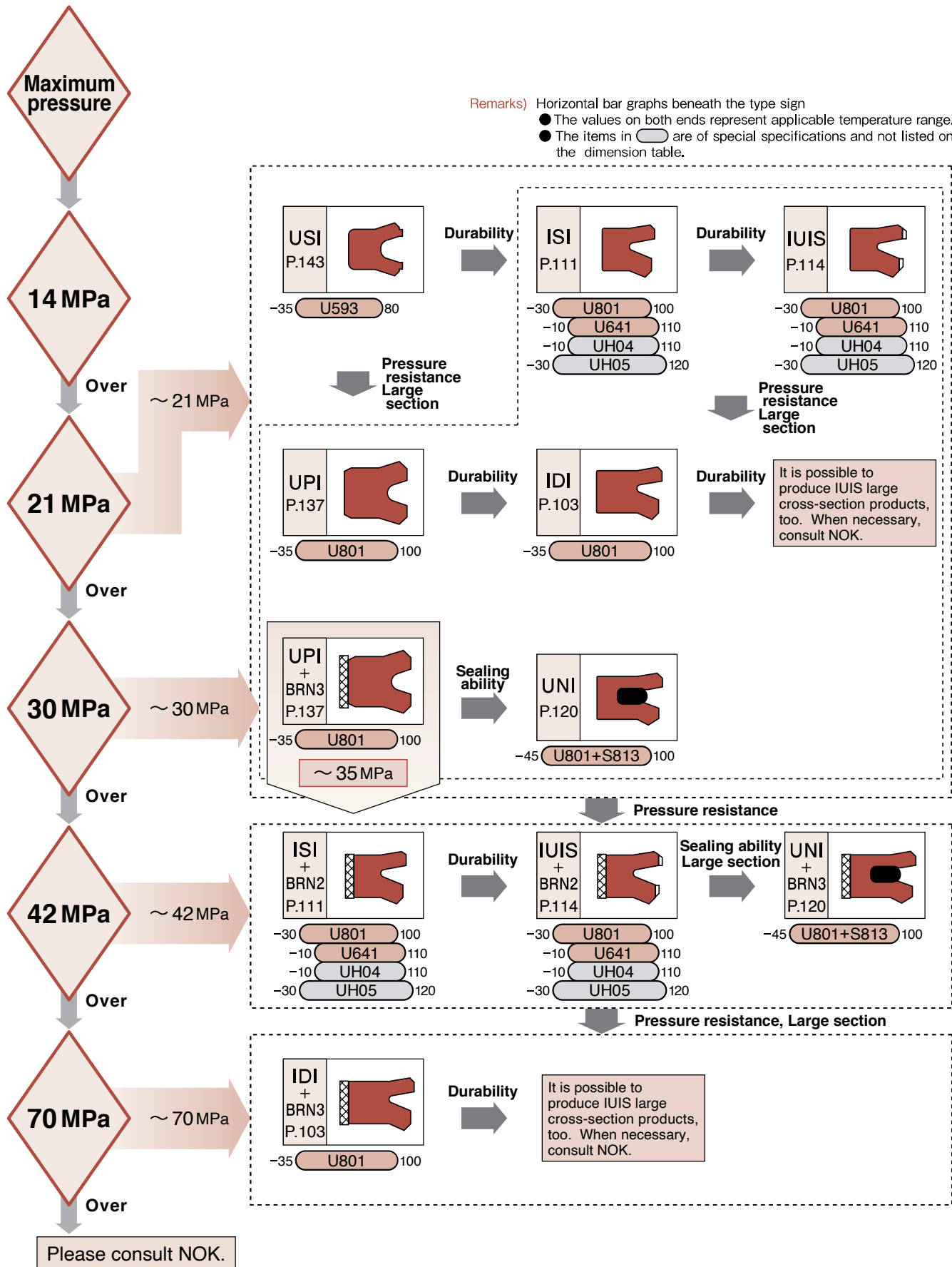

- Check the affinity between the oil that is used and the seal material, by referring to pages 271 to 292 and to the oil resistance data in Chapter I.
 - Check the sealing system of the equipment and model that are used, by referring to page 39 and to the use example in Chapter D.
- When using a special oil or using the under the condition outside the applicable range, consult NOK separately.

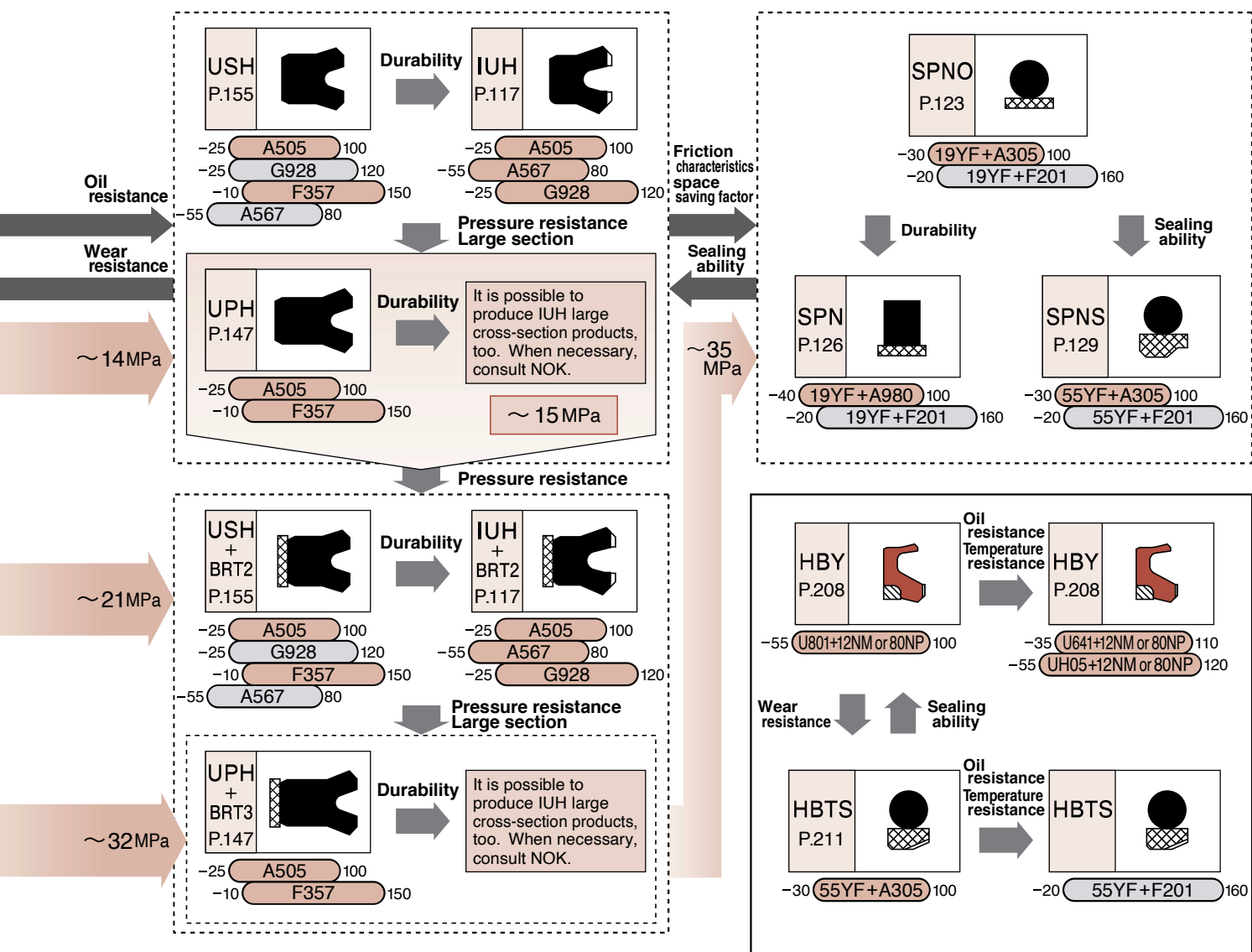

In combination with the buffer ring, the rod seal is effective in buffering the impact pressure, in inhibiting the oil temperature transfer, and in reducing the sliding heat generation, thus being able to improve the durability of the rod seal. (See "Buffer ring" on page 259.)

Example of sealing system using buffer rings

Example of system 1

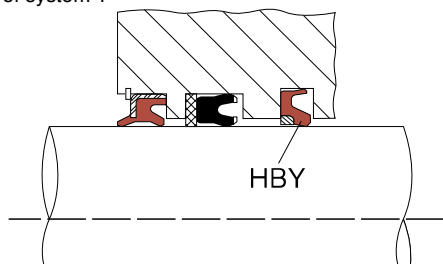

Example of system 2

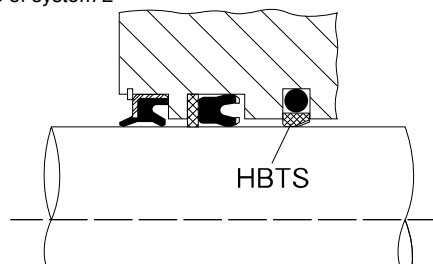

- ※1. When the minimum pressure that is applied is usually 3 MPa or larger, the life of the seal is decreased, so we recommend that the customer use the seal in combination with the buffer ring.
- ※2. In combination with the buffer ring, the customer can use the seal under high pressure. For example, in the case of IUH type packing, up to 34.3 MPa can be applied (see Hydraulic excavator, rod sealing system on page 47).

(2) Piston seals (Fig. B-12)

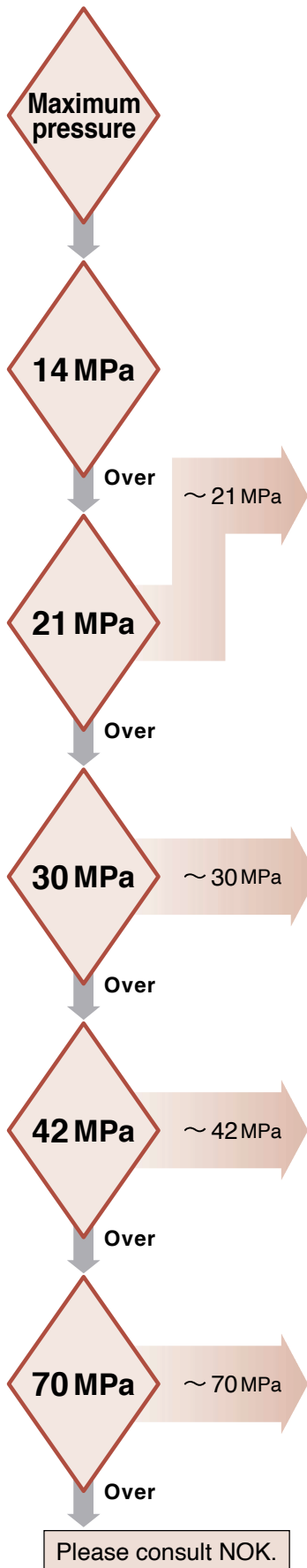

Remarks) Horizontal bar graphs beneath the type sign
 ● The values on both ends represent applicable temperature range.
 ● The items in are of special specifications and not listed on the dimension table.

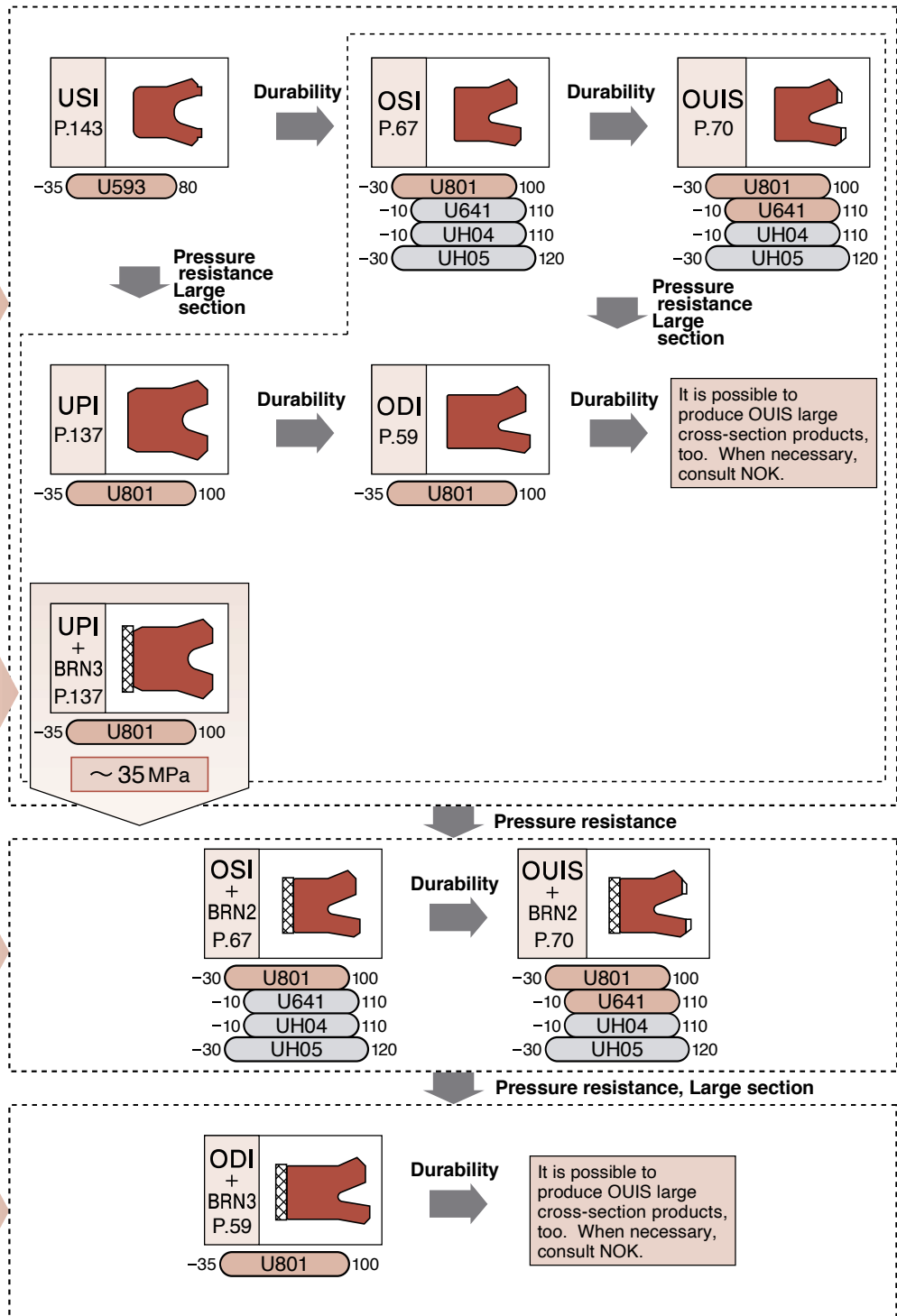

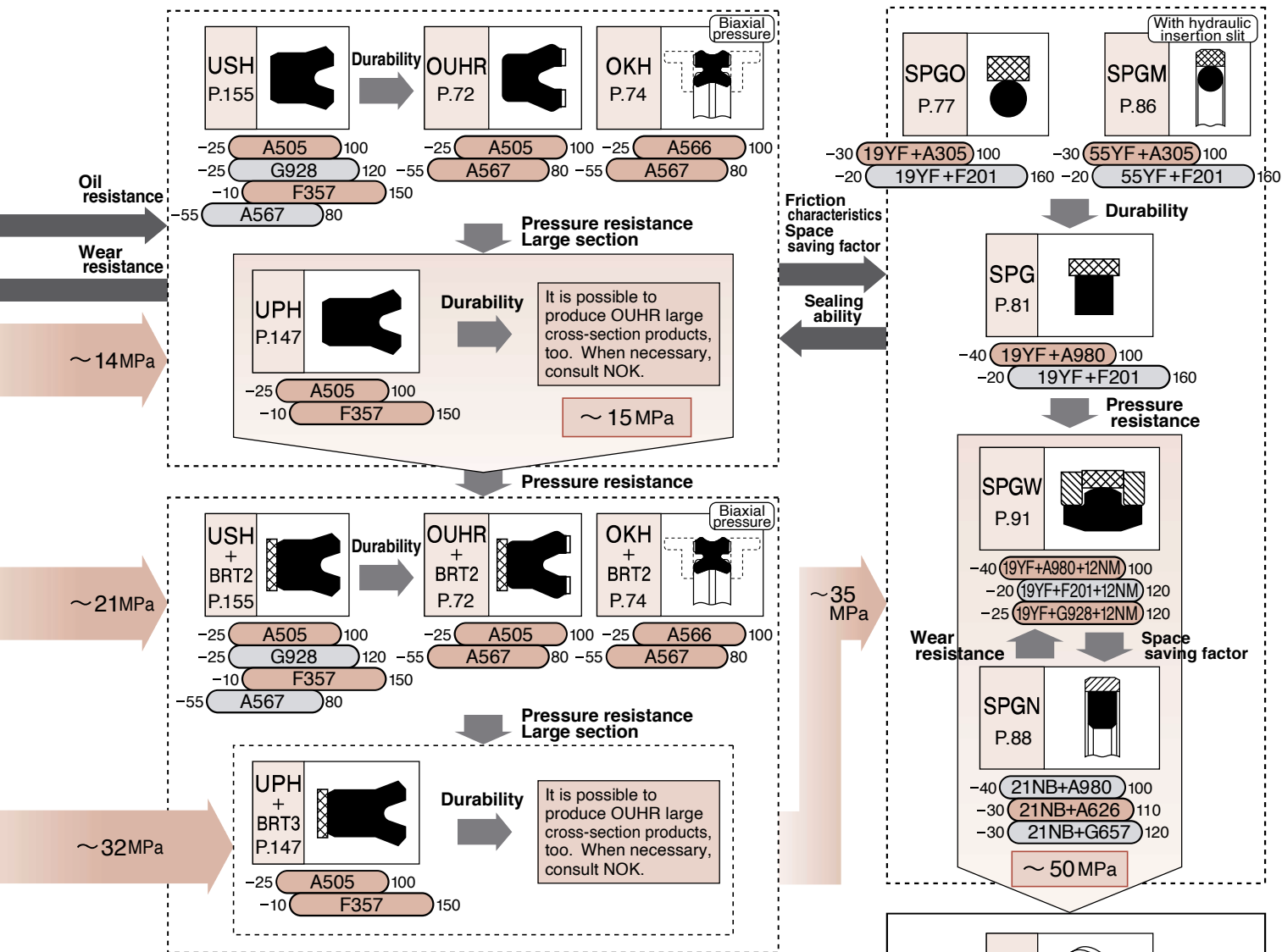

In combination with the contamination seal, the piston seal prevents damage due to foreign objects or adiabatic compression, thus being able to improve the durability of the piston seal. (See "Burnout phenomenon" on page 246.)

Example of sealing system using contami seals

Example of system 1

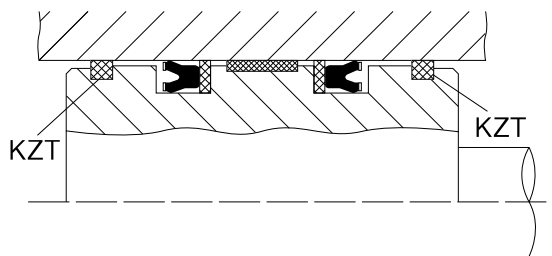

Example of system 2

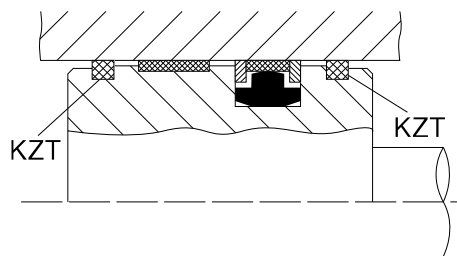

(3) Dust Seal

(Fig. B-13) Flow chart for selecting dust seal types

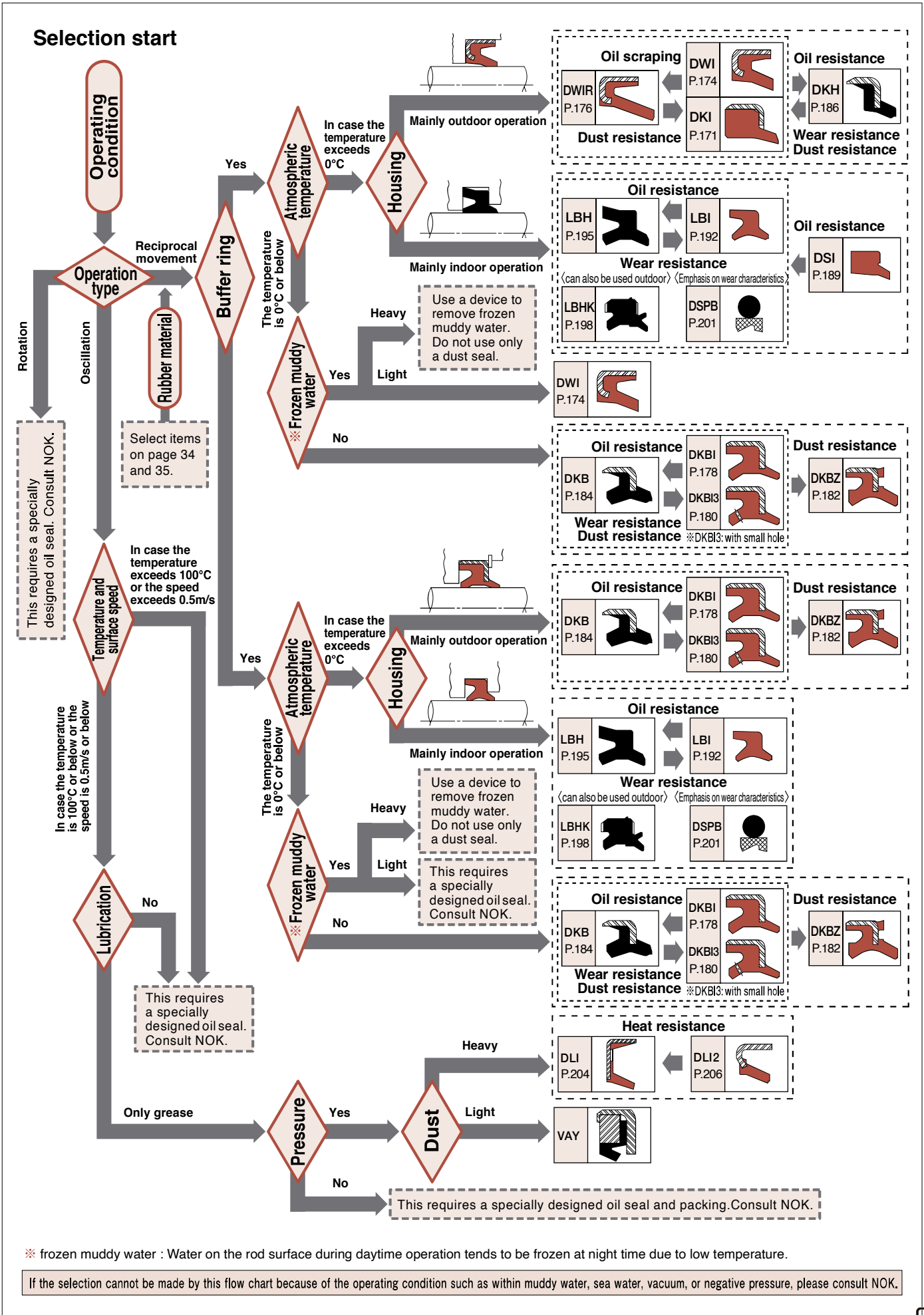

C

TYPES AND FEATURES OF NOK PACKINGS

Types and characteristics of rubber material ————— 34 ~ 35

Types and characteristics of resin material ————— 36 ~ 37

Low temperature retraction of rubber material ————— 36

Hardness of the material ————— 37

C. TYPES AND FEATURES OF NOK PACKINGS

NOK supplies several different types of packing materials to suit various applications. **Table C-1** shows the type and characteristics of rubber materials and **Table C-2** shows the type and characteristics of resin material. Standard materials are offered for items in this catalog to best meet the operating conditions. Refer to **chapter B** for the types and features of each type of packing. Compatibility in the following tables indicates general tendencies. For a specific brand-wise oil resistance, refer to pages **271 to 292** and to the oil resistance data in **chapter I**.

<Table C-1> Types and characteristics of NOK rubber material

Material	NOK material code	Material							Resistivity								
		Hardness (Durometer A) (Instant value)	Tensile strength (MPa)	100% modulus (MPa)	Elongation (%)	Permanent compression set (%) Test condition	Hardness change by air oven aging test (point) A : 80°C 70h B : 100°C 70h C : 120°C 70h D : 175°C 70h	Low temperature brittleness TR ₁₀ (°C)	Lubricating oil (agent)								
									Engine oil	Gear oil	Machine oil	Spindle oil	Refrigerator oil	Cup grease	Lithium grease	Silicon grease	
Nitrile rubber [NBR]	A102 (Black)	60	17	2.6	470	32 (B)	+ 7 (B)	- 22	○	○	○	○	○	○	○	○	○
	A103 (Black)	70	19	4.5	430	33 (B)	+ 5 (B)	- 22	○	○	○	○	○	○	○	○	○
	A104 (Black)	80	19	7.3	340	31 (B)	+ 5 (B)	- 21	○	○	○	○	○	○	○	○	○
	A216 (Black)	85	19	11	190	26 (B)	+ 5 (B)	- 36	○	○	○	○	○	○	○	○	○
	A297 (Black)	75	22	4.8	260	18 (B)	+ 5 (B)	- 34	○	○	○	○	○	○	○	○	○
	A305 (Black)	70	21	4.3	340	10 (B)	+ 2 (B)	- 23	○	○	○	○	○	○	○	○	○
	A402 (Black)	60	13	2.3	440	13 (B)	+ 3 (B)	- 26	○	○	○	○	○	○	○	○	○
	A505 (Black)	90	21	15	170	31 (B)	+ 2 (B)	- 22	○	○	○	○	○	○	○	○	○
	A527 (Black)	85	20	12	160	18 (B)	+ 3 (B)	- 57	○	○	○	○	○	○	○	○	○
	A566 (Black)	90	17	14	130	15 (B)	+ 3 (B)	- 34	○	○	○	○	○	○	○	○	○
	A567 (Black)	82	17	16	130	20 (B)	+ 4 (B)	- 55	○	○	○	○	○	○	○	○	○
	A626 (Black)	70	18	5	260	13 (B)	+ 7 (B)	- 35	○	○	○	○	○	○	○	○	○
	A795 (Black)	80	20	7.8	400	48 (B)	+ 6 (B)	- 11	○	○	○	○	○	○	○	○	○
A980 (Black)	80	14	11	150	17 (B)	+ 3 (B)	- 52	○	○	○	○	○	○	○	○	○	
Fluoro rubber [FKM]	F201 (Black)	70	14	5	230	7 (D)	0 (D)	- 15	○	△	○	○	○	○	○	○	○
	F357 (Black)	90	17	12	140	18 (D)	+ 1 (D)	- 15	○	△	○	○	○	○	○	○	○
	F548 (Black)	85	11	7.7	230	22 (D)	+ 1 (D)	- 16	○	△	○	○	○	○	○	○	○
	F975 (Brown)	80	11	7.9	220	33 (D)	0 (D)	- 18	○	△	○	○	○	○	○	○	○
Silicon rubber [VMQ]	S813 (Brown)	70	7.2	5.4	150	16 (D)	+ 1 (D)	- 49	○	△	○	△	△	△	△	△	×
Iron rubber [PUR]	U451 (Green)	92	43	11	500	30 (A)	0 (B)	- 30	○	△	○	○	○	○	○	○	○
	U593 (Green)	92	29	17	200	28 (A)	0 (B)	- 34	○	△	○	○	○	○	○	○	○
	U641 (Blue)	94	41	15	370	36 (A)	0 (B)	- 18	○	△	○	○	○	○	○	○	○
	U652 (Blue)	96	47	17	380	35 (A)	0 (B)	- 17	○	△	○	○	○	○	○	○	○
	U801 (Yellowish white)	94	52	13	500	32 (A)	0 (B)	- 29	○	△	○	○	○	○	○	○	○
	UH04 (Blue)	92	46	11	370	37 (A)	0 (B)	- 22	○	△	○	○	○	○	○	○	○
	UH08 (Brown)	90	37	9.5	340	29 (A)	0 (B)	- 26	○	△	○	○	○	○	○	○	○
UH05 (Purple)	95	51	19	430	36 (A)	0 (B)	- 27	○	△	○	○	○	○	○	○	○	
Fabric reinforced rubber	21AG (Black)	—	—	—	—	—	—	—	○	○	○	○	○	○	○	○	○
Hydrogenated nitrile rubber [H-NBR]	G869 (Black)	90	27	13	220	19 (C)	+ 2 (C)	- 28	○	○	○	○	○	○	○	○	○
	G928 (Black)	85	20	13	200	9 (C)	+ 1 (C)	- 22	○	○	○	○	○	○	○	○	○

Resistivity standards

- : Very good
 - : Good for most applications*
 - △ : Fair, can be used if no other materials exist, otherwise not recommended*
 - × : Not recommended
 - : No resistivity data available or the resistivity varies depending on the ingredient. Please consult NOK.
- * Please consult NOK before using these materials.

Resistivity																Features	Recommended NOK types	
Hydraulic fluid oil										Water and others				Heat resistance	Cold-temperature resistance			Wear resistance
Turbine oil	Oil-water emulsion type	Water + glycol type	Water soluble hydraulic fluid oil	Raw resolution type hydraulic fluid oil	Phosphate ester type	Silicon oil	Brake fluid	Torque converter oil	Water	Steam and hot water	Water soluble cutting oil	Chloric cutting oil	Sulfuric cutting oil					
○	○	○	○	○	×	○	△	○	△	△	○	×	○	○	○	○		CPH
○	○	○	○	○	×	○	△	○	△	△	○	×	○	○	○	○	Standard material of C shaped packings	CPH
○	○	○	○	○	×	○	△	○	△	△	○	×	○	○	○	○		CPH·DKH·VAY
○	○	○	○	○	×	○	△	△	△	×	△	×	○	○	○	○	Standard material of valve unit seals	SVY
○	○	○	○	○	×	○	△	△	△	×	△	×	○	○	○	○	Standard material of power steering seals	SCJY
○	○	○	○	○	×	○	△	△	○	×	△	×	○	○	○	○	Standard material of O ring (JIS B 2401 1 type A)	SPGC·SPNC·SPNO·SPGO SPNS·DSPB
○	○	○	○	○	×	○	△	△	○	×	△	×	○	○	○	○	Standard material of back ring for large diameter combination seals	SPG
○	○	○	○	○	×	○	△	○	○	×	△	×	○	○	○	○	Standard material of nitrile rubber packings	IUH·UPH·OUHR·LBH·LBHK·V96H·USH·CPH
○	○	○	○	△	×	○	△	△	△	×	△	×	△	○	○	○	Material of cold resistant packing (for general petroleum hydraulic fluid oil <small>Remark 2</small>)	OUHR·IUH·USH·LBH·LBHK
○	○	○	○	○	×	○	△	△	○	×	△	×	○	○	○	○	Standard material of OKH shaped packings	OKH
○	○	○	○	△	×	○	△	△	△	×	△	×	△	○	○	○	Material of cold resistant packing (mainly for Low temperature petroleum hydraulic fluid oil <small>Remark 3</small>)	OUHR·IUH·USH·LBH·LBHK
○	○	○	○	○	×	○	△	△	△	×	△	×	○	○	○	○	Standard material of back ring (O ring) for buffer rings	HBTS
○	○	○	○	○	×	○	△	△	△	○	×	○	○	△	○	○	Standard material of dust seals for reciprocal movement and oil seal for pressure resistance	TCV·TCZ·DKB·DKH
○	○	○	○	△	×	○	△	△	○	△	○	×	△	○	○	○	Standard material of back ring for combined seals	SPG·SPGW·SPN·DKB
○	△	△	○	○	○	○	△	○	△	△	○	○	○	△	○	○	Heat resistant material of back ring for combined seals	HBTS·SPG·SPGW·SPGC SPNC·SPNO·SPN·SPNS·DSPB
○	△	△	○	○	○	○	△	○	△	△	○	○	○	△	○	○	Standard material for heat resistant packings	UPH·USH·LBH·V96H
○	△	△	○	○	○	○	△	○	△	△	○	○	○	△	○	○	Heat resistant material of oil seals for pressure resistance	TCV·TCZ
○	△	△	○	○	○	○	×	○	△	×	△	○	○	○	△	○	Heat resistant material of dust seals for reciprocal movement	DKB·DKH
○	○	○	-	-	○	×	○	○	○	△	△	-	-	○	○	△	Material of back ring for U packings	UNI
○	×	×	×	○	×	○	×	○	△	×	×	-	-	○	○	○	Material of hinge pin dust seals	DLI2
○	×	×	×	○	×	○	×	○	△	×	×	-	-	○	○	○	Iron rubber improved for better cold resistance	USI·LBI·DLI
○	△	△	△	○	×	○	×	○	△	△	-	-	○	△	○	○	Iron rubber improved for better heat and water resistance	ISI·OUI·IUIS·HBY
○	△	△	△	○	×	○	×	○	△	△	-	-	○	△	○	○	Material for center swivel seals	CSI
○	×	×	×	○	×	○	×	○	△	×	×	-	-	○	○	○	Standard material of Iron rubber packings	ODI·OSI·CPI·IDI·ISI·UNI·UPI·IUIS·DKI·DKB·DKBZ·DWI·CSI·DSI·HBY·DWIR·DLI
○	△	△	△	○	×	○	×	○	△	△	-	-	○	○	○	○	Material for improving installation to the integrated groove	(Packings)
○	△	△	△	○	×	○	×	○	△	△	-	-	○	○	○	○	Material for improving installation to the integrated groove	(Packings)
○	△	△	△	○	×	○	×	○	△	△	-	-	○	○	○	○	Heat & cold resistant wide-range iron rubber	HBY
○	○	○	○	○	×	○	△	○	△	△	○	×	○	○	△	○	Standard material of fabric reinforced V packings (nitrile rubber)	V99F
○	○	○	○	○	×	○	△	○	○	○	○	×	○	○	○	○	Heat, water & water vapor resistant special nitrile rubber	(Packings)
○	○	○	○	○	×	○	△	○	×	△	×	○	○	○	○	○	Special nitrile rubber for better heat and wear resistance	SPGW·IUH

Remark 1) The property value is the measured value, not the guaranteed value.

Remark 2) A527 cannot be used for petroleum-derived work oil in low temperatures. (Rubber material may swell and soften, lowering the sealing performance.) When using petroleum-derived work oil in low temperatures, use A567.

Remark 3) A567 can be used for both general petroleum-derived work oil and petroleum-derived operating oil in low temperatures, however, when using general petroleum-derived work oil, we recommend using A527 which has superior oil-resistant properties. (Material for improving the extension of A903)

<Table C-2> Types and characteristics of NOK resin material

Material	NOK material code	Material						Resistivity								
		Hardness	Tensile strength (MPa)	Elongation (%)	Compression strength (MPa)		Applicable temperature range (°C)	Lubricating oil (agent)								
					2.5% deformation	10% deformation		Engine oil	Gear oil	Machine oil	Spindle oil	Refrigerator oil	Cup grease	Lithium grease	Silicon grease	
Rareflon [PTFE]	10FF (White)	58 (Durometer D)	38	400	9	16	-200 ~ 260	○	○	○	○	○	○	○	○	○
	34WF (White)	65 (Durometer D)	27	390	12	19	-200 ~ 260	○	○	○	○	○	○	○	○	○
	19YF (Brown)	70 (Durometer D)	20	180	14	22	-200 ~ 260	○	○	○	○	○	○	○	○	○
	49YF (Brown)	70 (Durometer D)	18	140	16	25	-200 ~ 260	○	○	○	○	○	○	○	○	○
	55YF (Brown)	70 (Durometer D)	20	200	16	23	-200 ~ 260	○	○	○	○	○	○	○	○	○
	11YF (Black)	66 (Durometer D)	19	320	12	18	-200 ~ 260	○	○	○	○	○	○	○	○	○
	31BF (Black)	66 (Durometer D)	21	330	13	20	-200 ~ 260	○	○	○	○	○	○	○	○	○
	05ZF (Brown)	68 (Durometer D)	25	290	12	20	-200 ~ 260	○	○	○	○	○	○	○	○	○
	08GF (Black)	68 (Durometer D)	20	260	14	22	-200 ~ 260	○	○	○	○	○	○	○	○	○
Polyamide resin [PA]	63NP (Blue)	109 (Rockwell R)	42	200	20	49	-55 ~ 100	○	○	○	○	○	○	○	○	○
	80NP (Black)	120 (Rockwell R)	79	15	39	73	-55 ~ 120	○	○	○	○	○	○	○	○	○
	12NM (Navy blue)	123 (Rockwell R)	102	8	38	100	-55 ~ 140	○	○	○	○	○	○	○	○	○
	21NB (gray)	122 (Rockwell R)	194	3	94	155	-55 ~ 130	○	○	○	○	○	○	○	○	○
Fabric reinforced phenolic resin	12RS (Dark brown)	105 (Rockwell M)	105 *Flex strength	—	207 *Destruction	—	-55 ~ 120	○	○	○	○	○	○	○	○	○
	15RS (Black)	105 (Rockwell M)	112 *Flex strength	—	234 *No Destruction	—	-55 ~ 120	○	○	○	○	○	○	○	○	○
Resin fiber polyester	88RS (light blue)	98 (Rockwell M)	85 *Flex strength	—	316 *No Destruction	—	-55 ~ 120	○	○	○	○	○	○	○	○	○

Resistivity standards ○ : Very good
 ○ : Good for most applications *
 △ : Fair, can be used if no other materials exist, otherwise not recommended *
 ※ Please consult NOK before using these materials.

Remark) The property value is the measured value, not the guaranteed value.

Low temperature retraction of rubber material

Apply to TR₁₀ Value

TR₁₀ value is used to judge low temperature capability of material. TR is an abbreviation for "Temperature-Retraction" as described by ASTM D 1329 and expresses the distortion recovery ability in low temperature. This is roughly the same as recovery of rubber-like elastomer. TR₁₀ value is the temperature where initial distortion has recovered by 10%. Fig. C-1 shows an example of measuring this value.

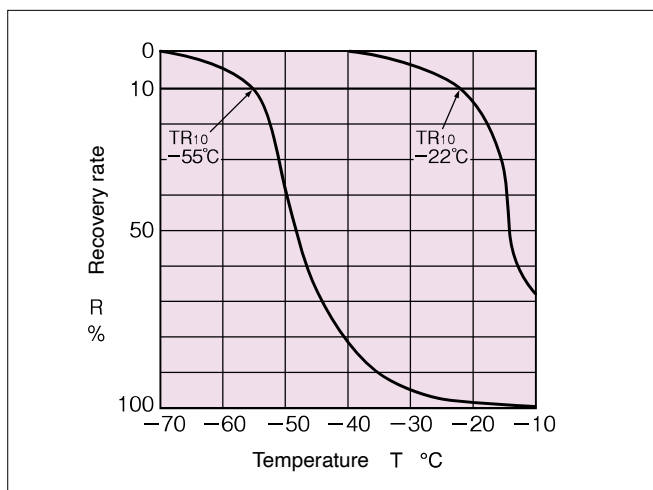

<Fig. C-1> TR graph

TR₁₀ values can indicate allowable low temperature service range of rubber material for packings. For allowable low temperature service range of specific types of packings, refer to page 14 to 19.

Resistivity															Features	Recommended NOK types	
Hydraulic fluid oil					Water and others					Heat resistance	Cold-temperature resistance	Wear resistance					
Turbine oil	Oil-water emulsion type	Water + glycol type	Water soluble hydraulic fluid oil	Raw resolution type hydraulic fluid oil	Phosphate ester type	Silicon oil	Brake fluid	Torque converter oil	Water				Steam and hot water	Water soluble cutting oil	Chloric cutting oil	Sulfuric cutting oil	
○	○	○	○	○	○	○	○	○	○	○	○	○	○	○	△	Pure PTFE. This material is the standard backup ring material for the O-ring.	(Backup ring)
○	○	○	○	○	○	○	○	○	○	○	○	○	○	○	○	This material is a rareflon material having better creep resistance than the pure PTFE.	(Backup ring)
○	○	○	○	○	○	○	○	○	○	○	○	○	○	○	○	Rareflon material with high extrusion and wear resistance.	BRT2,3·SPG·SPGW·SPGO·SPN·SPNO
○	○	○	○	○	○	○	○	○	○	○	○	○	○	○	○	Special material improving extrusion resistance of 19YF.	(Combined seals, backup ring)
○	○	○	○	○	○	○	○	○	○	○	○	○	○	○	○	This material is a special material that can be used in low lubrication areas.	SPGM·SPNS·HBTS
○	○	○	○	○	○	○	○	○	○	○	○	○	○	○	○	This material is a special material that can be used for water.	DSPB
○	○	○	○	○	○	○	○	○	○	○	○	○	○	○	○	Rareflon material with better wear and creep resistance than with pure PTFE.	SPGC·SPNC·BRT2,3
○	○	○	○	○	○	○	○	○	○	○	○	○	○	○	○	Bearing material containing bronze for high speed and light load.	KZT·RYT
○	○	○	○	○	○	○	○	○	○	○	○	○	○	○	○	This material is a bearing material excellent in load resistance and abrasion resistance.	(Piston seal, wear ring)
○	○	○	○	○	○	○	○	△	△	△	○	○	○	○	○	Material of backup ring for special seals.	BRL
○	○	○	○	○	○	○	○	△	△	△	○	○	○	○	○	Material of high pressure backup ring with high-wear resistance and mechanical strength. Its cutting manufacturing process makes large diameter seals available.	BRN2,3·SPGW·HBY
○	○	○	○	○	○	○	○	△	△	△	○	○	○	○	○	Material for injection molding having the same performance as 80NP with smaller dimension changes by water absorption	HBY·SPGW
○	○	○	○	○	○	○	○	△	△	△	○	○	○	○	○	Seal ring material with special filling, offering excellent wear resistance and mechanical strength.	SPGN
○	△	○	△	○	○	○	△	○	△	△	△	○	○	○	○	Material for bearing with excellent wear resistance and mechanical strength	(wear ring)
○	△	○	△	○	○	○	△	○	△	△	△	○	○	○	○	This material is a bearing material for improving the load resistance and abrasion resistance of 12RS.	(wear ring)
○	△	○	△	○	○	○	△	○	△	△	△	○	○	○	○	Bearing material with improved load resistance and easier assembly than the 12RS and 15RS.	(wear ring)

TYPES AND FEATURES OF NOK PACKINGS

■ Hardness of the material

Hardness of the material indicates pressure resistance and strength of a seal, including tensile strength. For example, the pressure resistance of rubber for a packing (extrusion resistance) is indicated by the hardness of the rubber (refer to **Fig. B-7** on page 25).

The testing method for material hardness is expressed by the industrial standard for each material as shown in **Table C-3**.

In this catalog, rubber hardness is expressed by spring-type hardness (JIS A) of JIS K 6253. **Fig. C-2** shows the correlation of each material hardness.

〈Table C-3〉 Testing method of material hardness

Vulcanized rubber	Rareflon (polytetrafluoroethylene resin)	Polyamide resin (thermoplastics resin)	Phenolic resin (thermosetting resin)
JIS K 6253	JIS K 7215	JIS K 7202	JIS K 6911

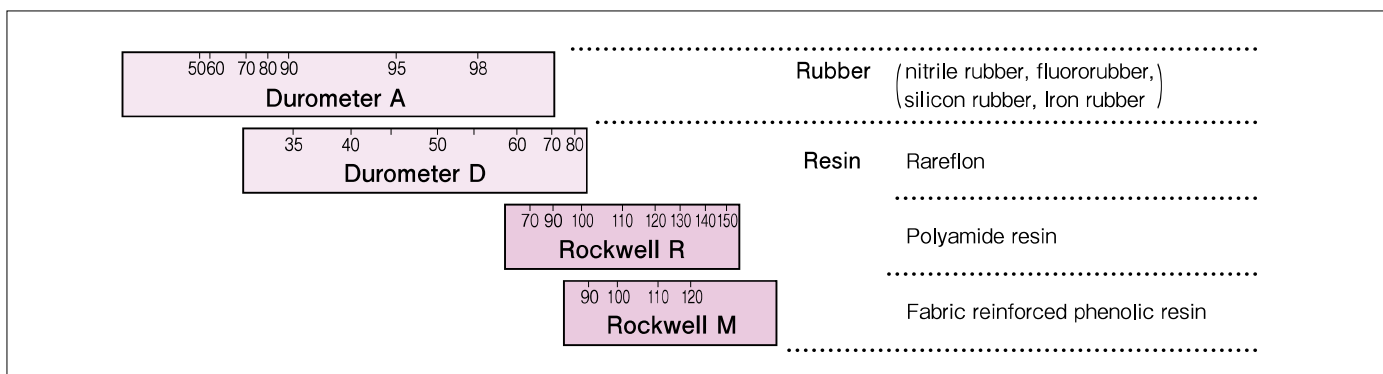

〈Fig. C-2〉 Correlation of each material hardness

D

APPLICATION EXAMPLES OF NOK PACKING

JIS Standard Cylinder
Application Examples — 40 ~ 43

Application Examples by
Equipments — 44 ~ 55

D. APPLICATION EXAMPLES OF NOK PACKING

The following classification shows typical application examples of various hydraulic equipment seals, including packings for reciprocal movement, dust seals for oscillating and rotating movement, and oil seals. These examples are NOK's recommended applications based on its significant experience in the market. Some special types without dimension tables are introduced here. If any types and materials with unique specifications are required, please consult NOK.

Classification of Application Example

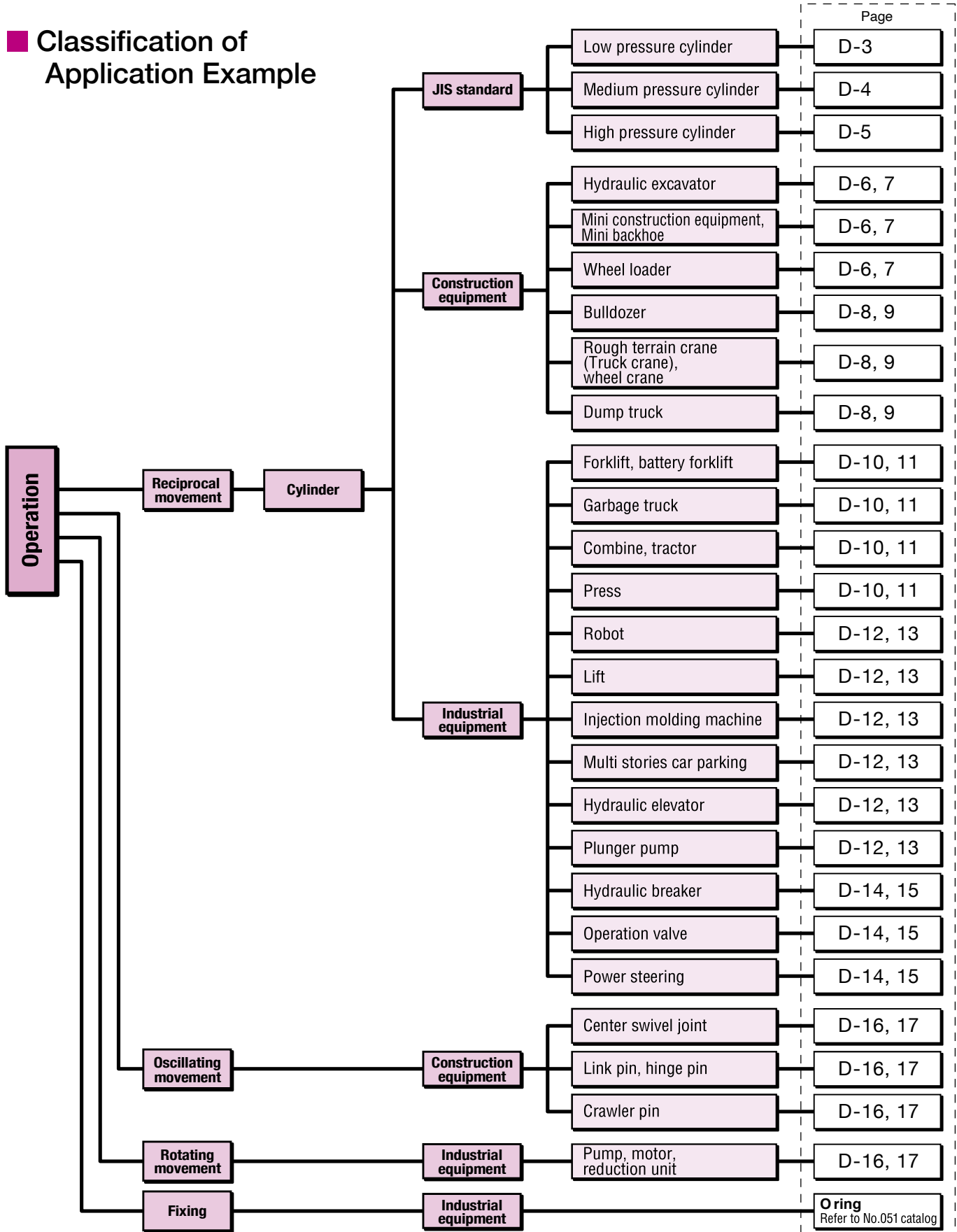

JIS Standard Cylinder (Old JIS B 8354 : 1992)

Hydraulic cylinder for low pressure : 7 MPa or below

◆Applicable temperature range: Standard specifications -20 ~ 80°C
Heat resistant specifications -10 ~ 120°C
Low temperature specifications -55 ~ 60°C

※ Old JIS B 8354 : 1992, the ambient temperature range is prescribed from -5 to 80°C. NOK, however, provides packings applicable for a wider range of temperature.

Remark) Items having — sign in the column of dimension table indicate special specifications. If the data of such items are required, please consult NOK.

Recommended example 1

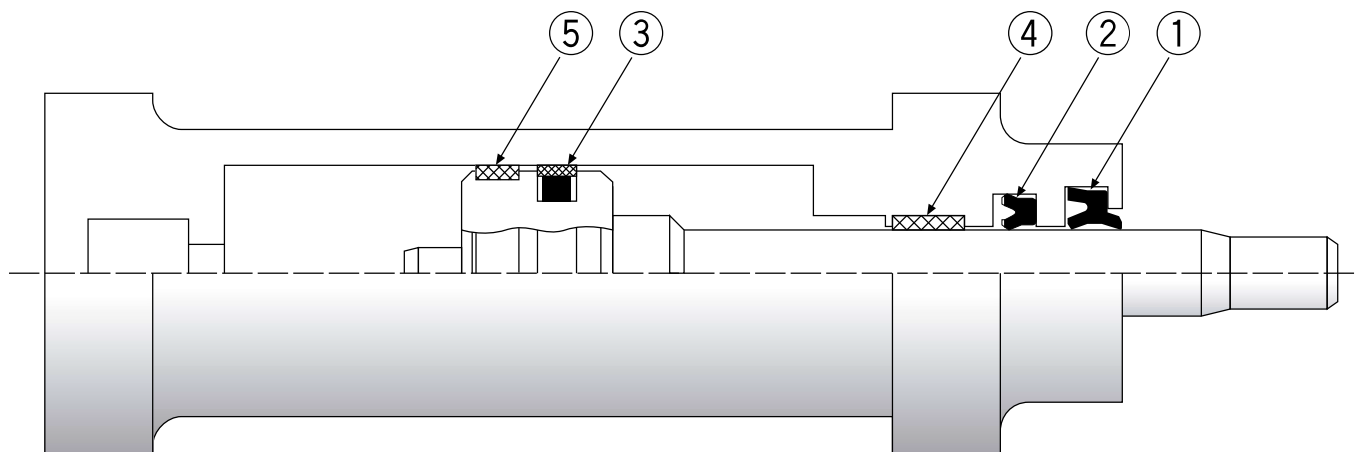

	Item	Standard specifications			Heat resistant specifications			Low temperature specifications			To reduce the sliding friction, The SPG is employed for the piston packing and small section U packing for rod packing. For the dust seal of low temperature application, instead of LBH, we recommend DKB with a metal case that has low shrinkage percentage of diameter at low temperature.
		Type	Material code	Dimension table (page)	Type	Material code	Dimension table (page)	Type	Material code	Dimension table (page)	
①	Dust seal	LBH	A505	195	LBH	F357	195	DKB	A980 SPCC	—	
②	Rod packing	IUH	A505	117	USH	F357	155	IUH	A567	117	
③	Piston packing	SPG	19YF A980	81	SPG	19YF F201	—	SPG	19YF A980	81	
④	Wear ring	RYT	05ZF	214	RYT	05ZF	214	RYT	05ZF	214	
⑤	Wear ring	RYT	05ZF	214	RYT	05ZF	214	RYT	05ZF	214	

Recommended example 2

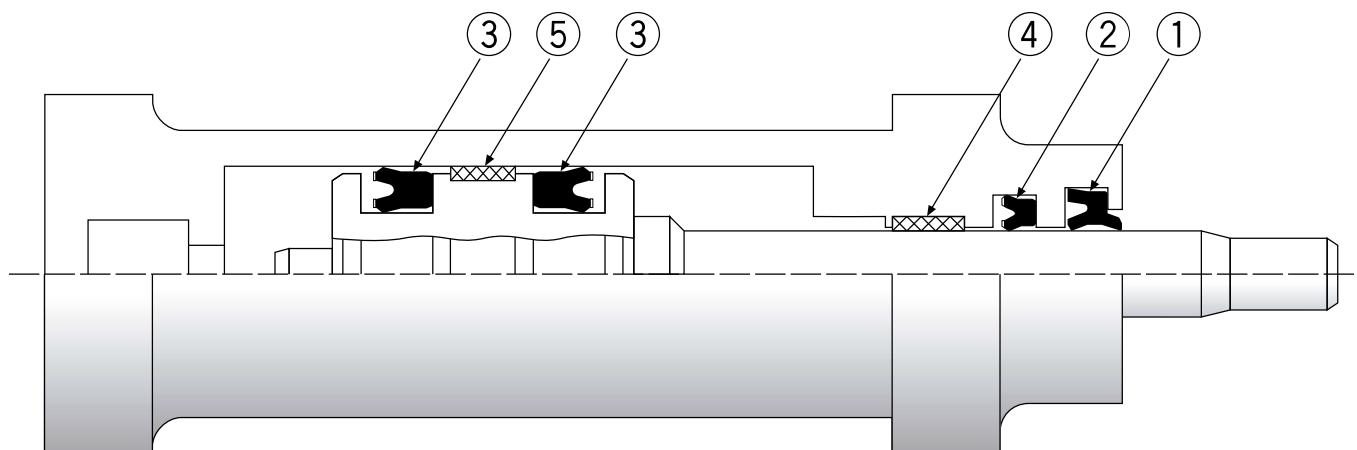

	Item	Standard specifications			Heat resistant specifications			Low temperature specifications			To reduce the sliding friction, The SPG is employed for the piston packing and small section U packing for rod packing. For the dust seal of low temperature application, instead of LBH, we recommend DKB with a metal case that has low shrinkage percentage of diameter at low temperature.
		Type	Material code	Dimension table (page)	Type	Material code	Dimension table (page)	Type	Material code	Dimension table (page)	
①	Dust seal	LBH	A505	195	LBH	F357	195	DKB	A980 SPCC	—	
②	Rod packing	IUH	A505	117	USH	F357	155	IUH	A567	117	
③	Piston packing	OUHR	A505	72	USH	F357	155	OUHR	A567	72	
④	Wear ring	RYT	05ZF	214	RYT	05ZF	214	RYT	05ZF	214	
⑤	Wear ring	RYT	05ZF	214	RYT	05ZF	214	RYT	05ZF	214	

JIS Standard Cylinder (Old JIS B 8354:1992)

Hydraulic cylinder for medium pressure : 14 MPa or below

◆Applicable temperature range: Standard specifications -20 ~ 80°C
Heat resistant specifications -10 ~ 120°C
Low temperature specifications -55 ~ 60°C

※ Old JIS B 8354:1992, the ambient temperature range is prescribed from -5 to 80°C. NOK, however, provides packings applicable for a wider range of temperature.

Remark) Items having — sign in the column of dimension table indicate special specifications. If the data of such items are required, please consult NOK.

Recommended example 3

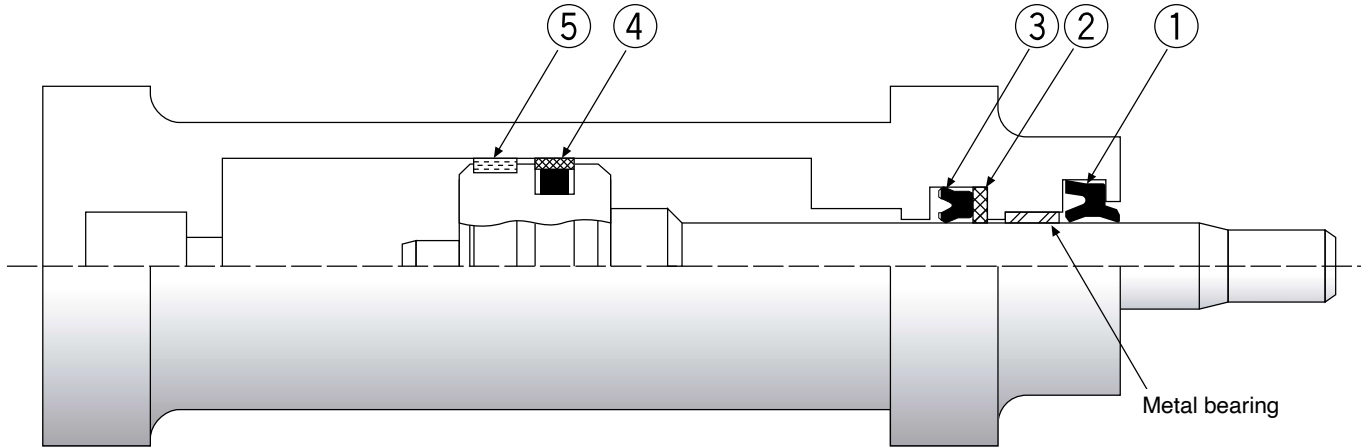

	Item	Standard specifications			Heat resistant specifications			Low temperature specifications			The low friction SPG packing and high load durability wear ring are employed for the piston. For the dust seal of low temperature application, instead of LBH, we recommend DKB with a metal case that has low shrinkage percentage of diameter at low temperature.
		Type	Material code	Dimension table (page)	Type	Material code	Dimension table (page)	Type	Material code	Dimension table (page)	
①	Dust seal	LBH	A505	195	LBH	F357	195	DKB	A980 SPCC	—	
②	Backup ring	BRT2	19YF	117	BRT2	19YF	155	BRT2	19YF	117	
③	Rod packing	IUH	A505	117	USH	F357	155	IUH	A567	117	
④	Piston packing	SPG	19YF A980	81	SPG	19YF F201	—	SPG	19YF A980	81	
⑤	Wear ring	WR	12RS	217	WR	12RS	217	WR	12RS	217	

Recommended example 4

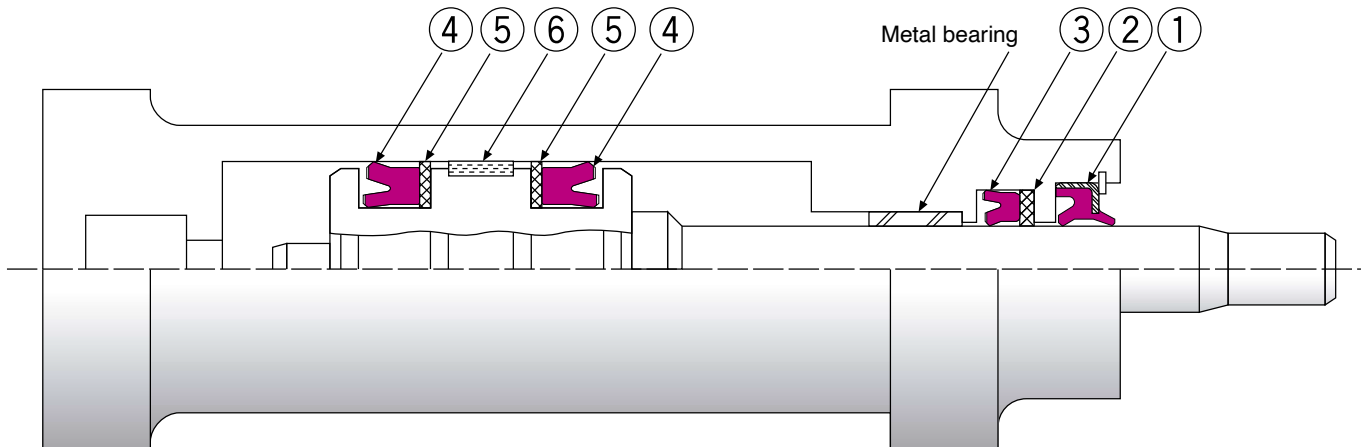

	Item	Standard specifications			Heat resistant specifications			Low temperature specifications			The U packings are employed to improve the sealing ability of piston.
		Type	Material code	Dimension table (page)	Type	Material code	Dimension table (page)	Type	Material code	Dimension table (page)	
①	Dust seal	DKBI	U801 SPCC	178	LBH	F357	195	DKB	A980 SPCC	—	
②	Backup ring	—	—	—	BRT2	19YF	155	BRT2	19YF	117	
③	Rod packing	IUIS	U801	114	USH	F357	155	IUH	A567	117	
④	Piston packing	OUIS	U801	70	USH	F357	155	OUHR	A567	72	
⑤	Backup ring	—	—	—	BRT2	19YF	155	BRT2	19YF	72	
⑥	Wear ring	WR	12RS	217	WR	12RS	217	WR	12RS	217	

JIS Standard Cylinder (Old JIS B 8354 : 1992)

Hydraulic cylinder for high pressure : 21 MPa or below

◆Applicable temperature range : Standard specifications -20 ~ 80°C
Heat resistant specifications -10 ~ 120°C
Low temperature specifications -55 ~ 60°C

※ Old JIS B 8354 : 1992, the ambient temperature range is prescribed from -5 to 80°C. NOK, however, provides packings applicable for a wider range of temperature.

Remark) Items having — sign in the column of dimension table indicate special specifications. If the data of such items are required, please consult NOK.

Recommended example 5

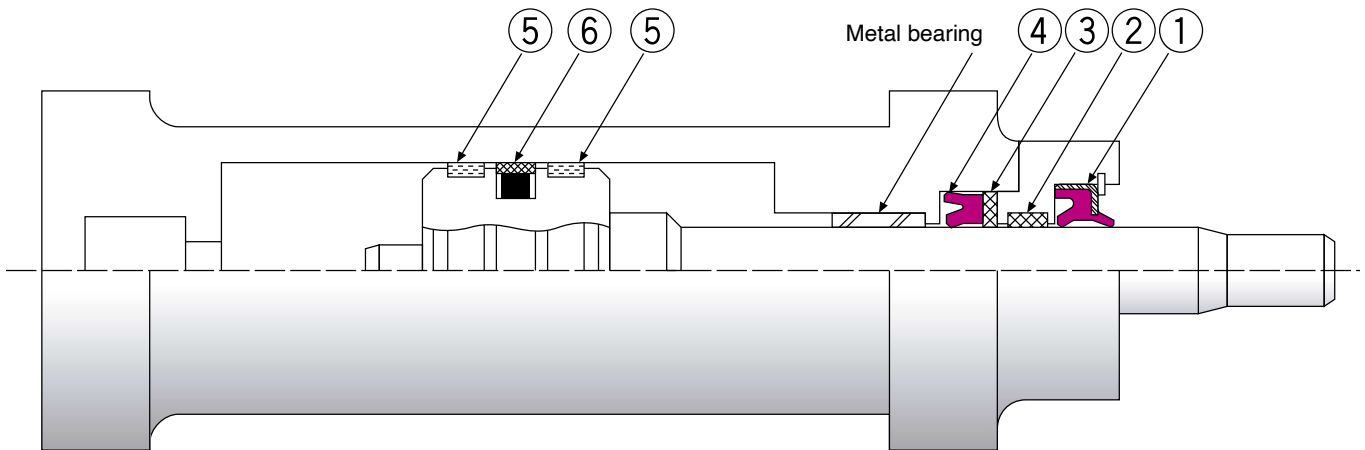

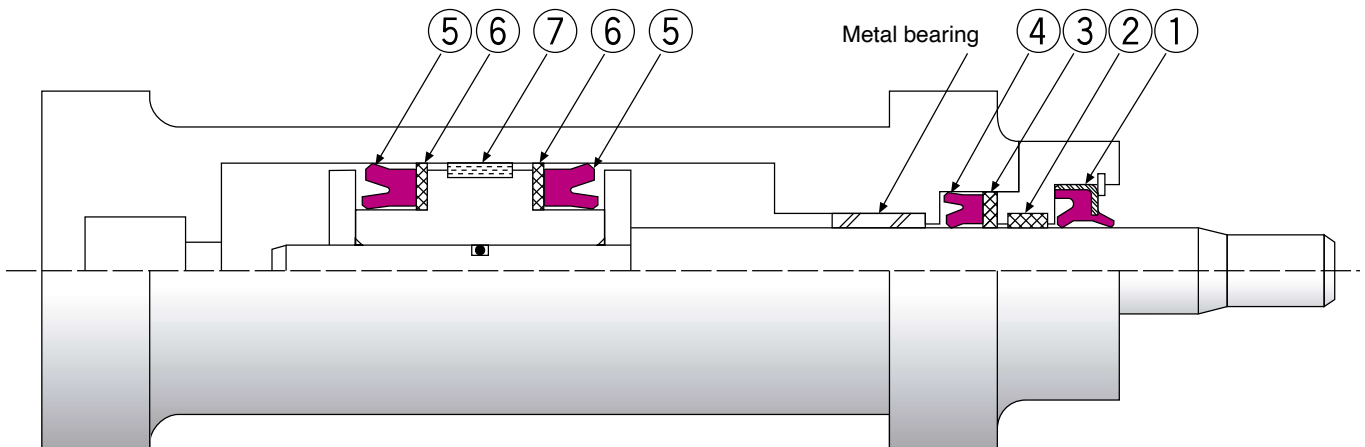

	Item	Standard specifications			Heat resistant specifications			Low temperature specifications			The low friction SPG packing and the high load durability wear ring are employed for the piston. The large section U packing are employed for the rod packing considering its high durability.
		Type	Material code	Dimension table (page)	Type	Material code	Dimension table (page)	Type	Material code	Dimension table (page)	
①	Dust seal	DKBI	U801 SPCC	178	LBH	F357	195	DKBI	U801 SPCC	178	
②	Wear ring	RYT	05ZF	214	RYT	05ZF	214	RYT	05ZF	214	
③	Backup ring	—	—	—	BRT2	19YF	147	BRT2	19YF	—	
④	Rod packing	IDI	U801	103	UPH	F357	147	UPH	A567	—	
⑤	Wear ring	WR	12RS	217	WR	12RS	217	WR	12RS	217	
⑥	Piston packing	SPG	19YF A980	81	SPG	19YF F201	—	SPG	19YF A980	81	

Recommended example 6



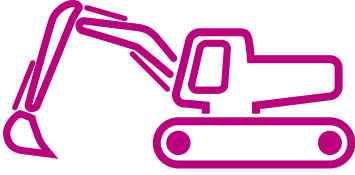

	Item	Standard specifications			Heat resistant specifications			Low temperature specifications			The U packings are employed to improve the sealing ability of piston.
		Type	Material code	Dimension table (page)	Type	Material code	Dimension table (page)	Type	Material code	Dimension table (page)	
①	Dust seal	DKBI	U801 SPCC	178	LBH	F357	195	DKBI	U801 SPCC	178	
②	Wear ring	RYT	05ZF	214	RYT	05ZF	214	RYT	05ZF	214	
③	Backup ring	—	—	—	BRT2	19YF	147	BRT2	19YF	—	
④	Rod packing	IDI	U801	103	UPH	F357	147	UPH	A567	—	
⑤	Piston packing	ODI	U801	59	UPH	F357	147	UPH	A567	—	
⑥	Backup ring	—	—	—	BRT2	19YF	147	BRT2	19YF	—	
⑦	Wear ring	WR	12RS	217	WR	12RS	217	WR	12RS	217	

Application Examples by Equipment

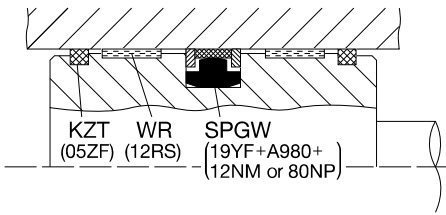
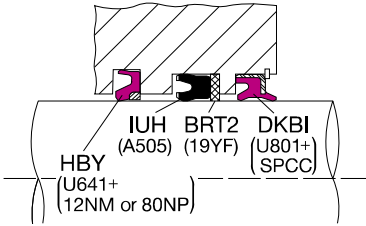
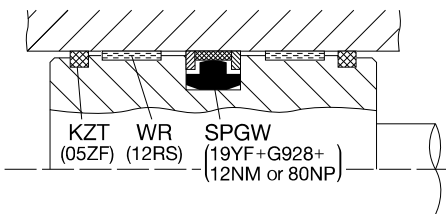
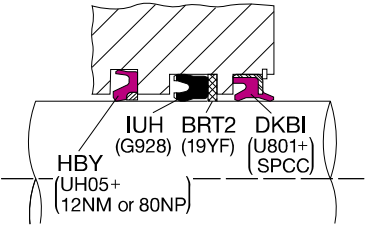
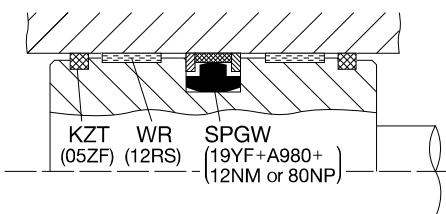
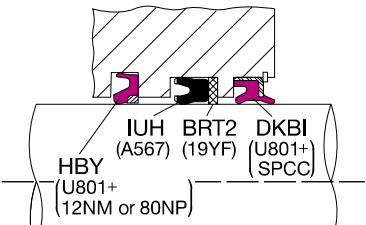
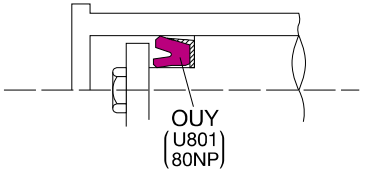
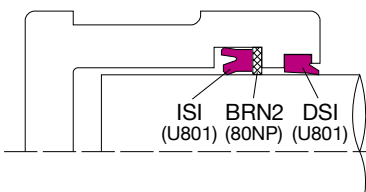
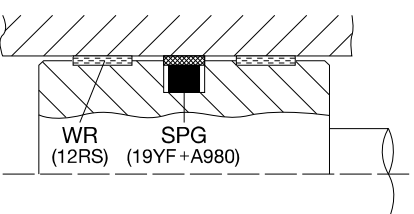
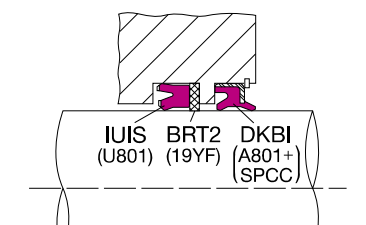
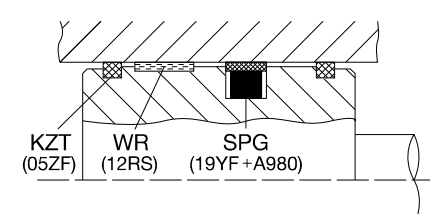
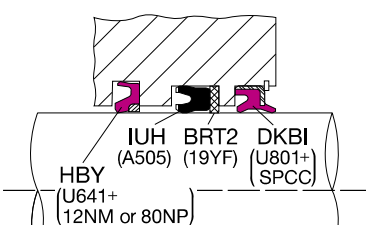
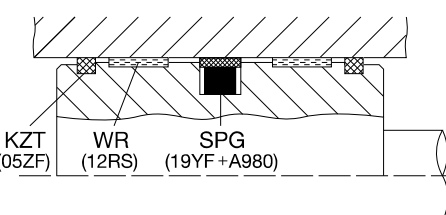
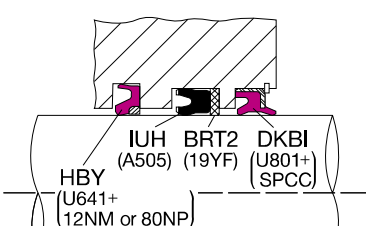
Equipment	Application	Operating condition
 <p>Hydraulic excavator</p>		Standard specifications 0 ~ 34MPa -30 ~ 100°C
	Boom cylinder Arm cylinder Bucket cylinder	Heat resistance specifications 0 ~ 34MPa -30 ~ 120°C
		Cold resistance specifications 0 ~ 34MPa -50 ~ 80°C
	Adjust cylinder (grease cylinder)	0 ~ 79MPa -30 ~ 100°C
 <p>Mini construction equipment Mini back hoe</p>	Boom cylinder Arm cylinder Bucket cylinder Blade cylinder	0 ~ 21MPa -30 ~ 100°C
 <p>Wheel loader</p>	Hoist cylinder Bucket cylinder	0 ~ 21MPa -30 ~ 100°C
	Steering cylinder	0 ~ 21MPa -30 ~ 100°C



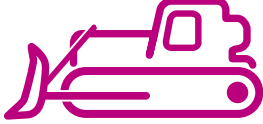
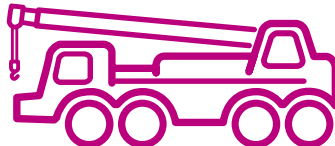

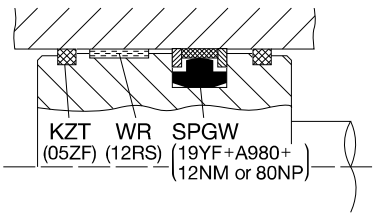
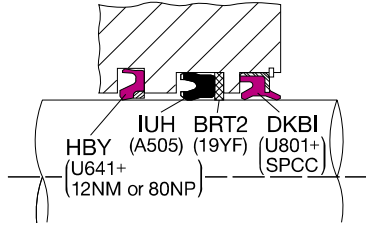
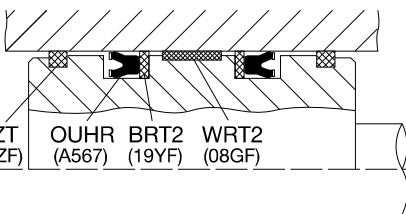
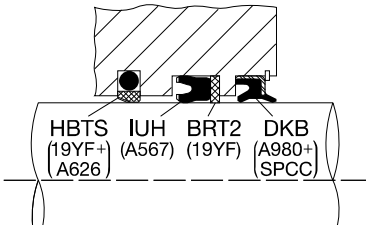
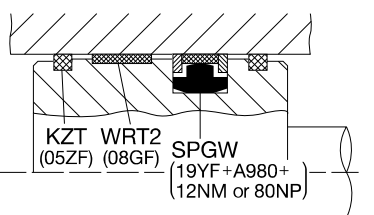
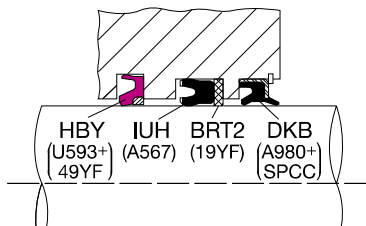
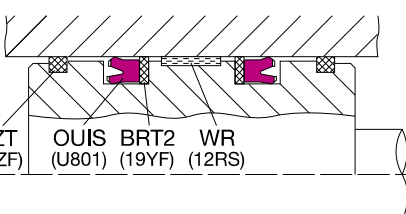
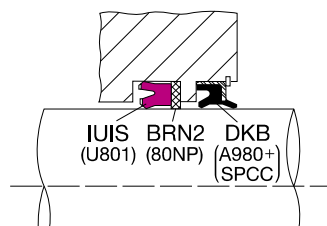
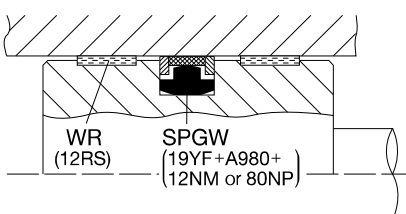
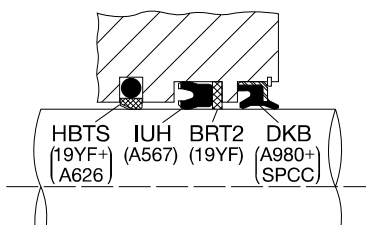
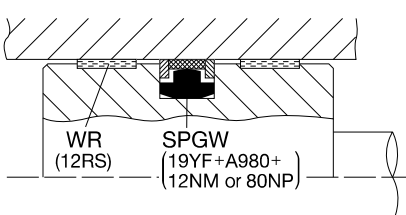
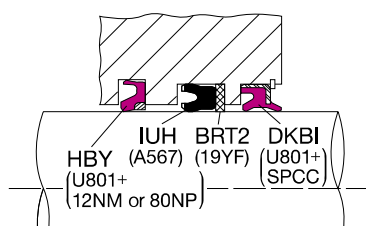

Piston sealing system	Feature	Rod sealing system	Feature
 <p>KZT (05ZF) WR (12RS) SPGW (19YF+A980+ (12NM or 80NP))</p>	<p>High durability for severe operating condition with the selected materials; SPGW that is applicable for high pressure and KZT that removes foreign objects in hydraulic fluid oil and prevents seal damages caused by adiabatic compression</p>	 <p>IUH (A505) BRT2 (19YF) DKBI (U801+) (SPCC) HBY (U641+ (12NM or 80NP))</p>	<p>HBY is used to prolong life of the rod seal, and nitrile rubber. (A505) having good oil resistance and backup ring (19YF) are used for rod seals.</p>
 <p>KZT (05ZF) WR (12RS) SPGW (19YF+G928+ (12NM or 80NP))</p>	<p>Hydrogenated nitrile rubber (G928) is applied to the back ring of SPGW to enable high temperature operation.</p>	 <p>IUH (G928) BRT2 (19YF) DKBI (U801+) (SPCC) HBY (UH05+ (12NM or 80NP))</p>	<p>Cold to heat resistant Iron rubber (UH05) is used for HBY and hydrogenated nitrile rubber (G928) for rod seals. Oil scraping can be prevented by using DKBI.</p>
 <p>KZT (05ZF) WR (12RS) SPGW (19YF+A980+ (12NM or 80NP))</p>	<p>Standard material for back ring of SPGW is low temperature resistant nitrile rubber.</p>	 <p>IUH (A567) BRT2 (19YF) DKBI (U801+) (SPCC) HBY (U801+ (12NM or 80NP))</p>	<p>Low temperature resistant nitrile rubber (A567) is used for IUH.</p>
 <p>OUY (U801) (80NP)</p>	<p>Special seal for piston OUY is used to enable the operation of extremely short strokes under high pressure (under such operation, oil film can be broken with ordinary seals).</p>	 <p>ISI (U801) BRN2 (80NP) DSI (U801)</p>	<p>Because of small operation range of pressure, ISI is used in combination with backup ring of polyamide resin(80NP) of high extrusion proof characteristics.</p>
 <p>WR (12RS) SPG (19YF+A980)</p>	<p>Compact SPG for medium pressure is used. Two WR are used to prevent scoring between the piston head and the cylinder tube that can be caused by high lateral load typical for such operating condition.</p>	 <p>IUIS (U801) BRT2 (19YF) DKBI (A801+) (SPCC)</p>	<p>To prevent extrusion, the backup ring is used for IUIS. To prevent oil scrape-out, DKBI is used for dust seals.</p>
 <p>KZT (05ZF) WR (12RS) SPG (19YF+A980)</p>	<p>Compact SPG for medium pressure is used.</p>	 <p>IUH (A505) BRT2 (19YF) DKBI (U801+) (SPCC) HBY (U641+ (12NM or 80NP))</p>	<p>HBY (U641 + 80NP) is used to prevent sliding heat increase at the packings. Nitrile rubber (A505) is used for IUH.</p>
 <p>KZT (05ZF) WR (12RS) SPG (19YF+A980)</p>		 <p>IUH (A505) BRT2 (19YF) DKBI (U801+) (SPCC) HBY (U641+ (12NM or 80NP))</p>	<p>Because of wide operation range of pressure, HB Y (U641 + 80NP) is used. Nitrile rubber (A505) is used for IUH.</p>

Application Examples by Equipment

Equipment	Application	Operating condition
 <p>Bulldozer</p>	<p>Hoist cylinder</p> <p>Blade cylinder</p>	<p>0 ~ 34MPa</p> <p>-30 ~ 100°C</p>
 <p>Rough terrain crane (Truck crane)</p>  <p>Wheel crane</p>	<p>Derricking cylinder</p> <p>Telescopic cylinder</p> <p>Slide cylinder</p>	<p>0 ~ 21MPa</p> <p>-40 ~ 80°C</p>
	<p>Jack cylinder</p>	<p>0 ~ 31MPa</p> <p>-30 ~ 100°C</p>
	<p>Hydraulic suspension cylinder</p>	<p>0 ~ 21MPa</p> <p>-30 ~ 100°C</p>
	 <p>Dump truck</p>	<p>Dump cylinder</p>



Piston sealing system	Feature	Rod sealing system	Feature
 <p>KZT (05ZF) WR (12RS) SPGW (19YF+A980+ (12NM or 80NP))</p>	<p>SPGW is used in high impact pressure. KZT is used for both ends to prevent heat damage of packings by adiabatic compression.</p>	 <p>IUH (A567) BRT2 (19YF) DKBI (U801+ (SPCC)) HBY (A505) (19YF) (U641+ (12NM or 80NP))</p>	<p>HBY is used to improve durability of the rod seal. Nitrile rubber (A505, high oil resistance material) and backup ring (19YF) are used for rod seals.</p>
 <p>KZT (05ZF) OUHR (A567) BRT2 (19YF) WRT2 (08GF)</p>	<p>OUHR with stick slip proof characteristics is used considering operating conditions that require keeping extended work pressure. 08GF having small friction resistance is used for wear ring material.</p>	 <p>HBTS (19YF+) (A626) IUH (A567) BRT2 (19YF) DKB (A980+ (SPCC))</p>	<p>HBTS is also used to prevent stick slip.</p>
 <p>KZT (05ZF) WRT2 (08GF) SPGW (19YF+A980+ (12NM or 80NP))</p>	<p>SPGW is used in high pressure operating conditions. 08GF having small friction resistance is used for wear ring material to prevent stick slip. KZT is used to prevent heat damage of the seals. By the combination of all above features, this system is excellent for severe operating condition.</p>	 <p>HBY (U593+ (49YF)) IUH (A567) BRT2 (19YF) DKB (A980+ (SPCC))</p>	<p>HBY, specially designed, absorbs surge pressure for improving durability of the rod seal.</p>
 <p>KZT (05ZF) OUIS (U801) BRT2 (19YF) WR (12RS)</p>	<p>OUIS is used in combination with backup rings to improve sealing ability.</p>	 <p>IUIS (U801) BRN2 (80NP) DKB (A980+ (SPCC))</p>	<p>To prevent extrusion, backup rings are used for IUIS. DKB (A980) excellent in low temperature sealing characteristics and in scrape-out resistance is used for dust seals.</p>
 <p>WR (12RS) SPGW (19YF+A980+ (12NM or 80NP))</p>	<p>SPGW is used to meet the operating condition that requires durability against impact pressure and extremely short strokes.</p>	 <p>HBTS (19YF+) (A626) IUH (A567) BRT2 (19YF) DKB (A980+ (SPCC))</p>	<p>To reduce the damage to rod seals, HBTS is used. IUH (A567) with high sealing ability in low temperature is also used.</p>
 <p>WR (12RS) SPGW (19YF+A980+ (12NM or 80NP))</p>	<p>For the operating condition that requires extremely high pressure, SPGW is used. Two WR are used considering lateral load that is typical for such operating condition.</p>	 <p>IUH (A567) BRT2 (19YF) DKBI (U801+ (SPCC)) HBY (U801+ (12NM or 80NP))</p>	<p>Considering the extremely high operating pressure, HBY is used to reduce damage to rod seals. IUH (A567) with high sealing ability in low temperature is used.</p>

Application Examples by Equipment

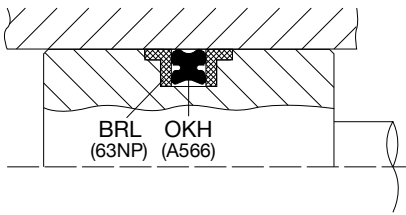
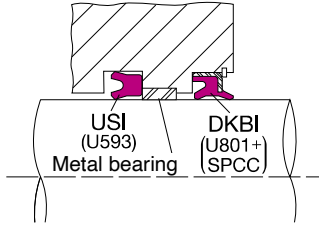
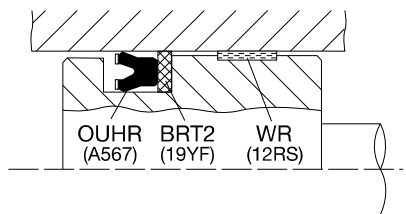
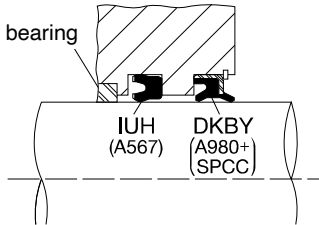
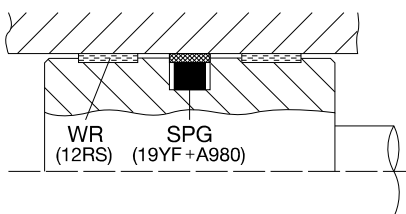
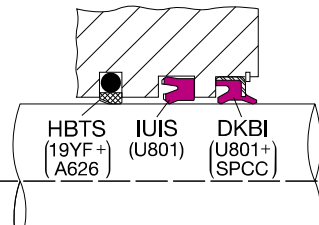
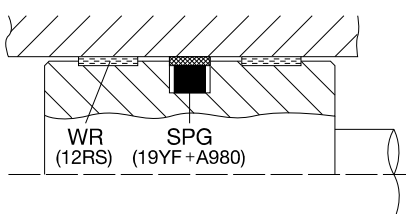
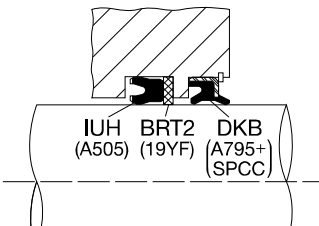
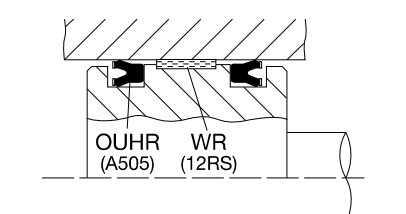
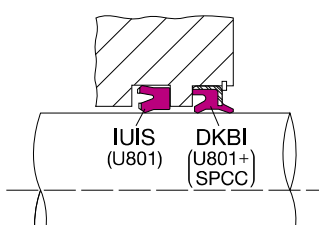
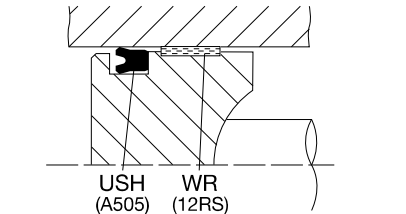
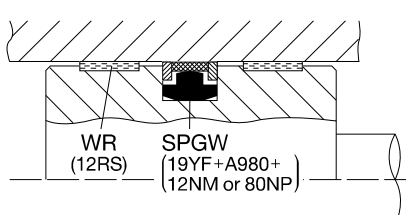
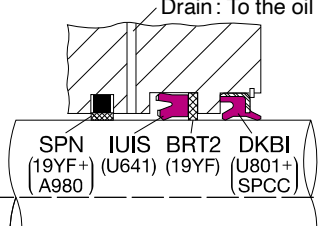
Equipment	Application	Operating condition
 Forklift  Battery forklift	Tilt cylinder	0 ~ 21MPa -30 ~ 100°C
	Lift cylinder (low temperature specifications)	0 ~ 21MPa -55 ~ 80°C
	Steering cylinder	0 ~ 21MPa -30 ~ 100°C
 Garbage truck	—	0 ~ 21MPa -30 ~ 100°C
 Combine  Farm tractor	Double acting cylinder	0 ~ 14MPa -30 ~ 100°C
	Single acting cylinder	0 ~ 14MPa -30 ~ 100°C
 Pressing machine	—	0 ~ 28MPa -10 ~ 80°C

Piston sealing system	Feature	Rod sealing system	Feature
 <p>BRL (63NP) OKH (A566)</p>	Compact OKH assures easy assembly and high sealing ability.	 <p>USI (U593) Metal bearing DKBI (U801+ SPCC)</p>	The combination of USI and DKBI is used to realize compact sealing system.
 <p>OUHR (A567) BRT2 (19YF) WR (12RS)</p>	OUHR is used because maintaining oil film is important for such single acting cylinder.	 <p>Metal bearing IUH (A567) DKBY (A980+ SPCC)</p>	IUH is used in combination with DKBY because of the fluid filling type single acting cylinder. Dust seals are specially designed DKBY.
 <p>WR (12RS) SPG (19YF+A980)</p>	SPG is usable for operating condition requiring extremely short strokes. If there is a high frequency of pressurization, we recommend SPGY with slits on the Rareflon ring side to prevent venting leaks	 <p>HBTS (19YF+ A626) IUIS (U801) DKBI (U801+ SPCC)</p>	HBTS is used for buffer rings because this system is used in sealed conditions.
 <p>WR (12RS) SPG (19YF+A980)</p>	SPG with high durability is used. Two WR are used to prevent scoring between the piston head and the cylinder tube that can be caused by high lateral load typical for such operating condition.	 <p>IUH (A505) BRT2 (19YF) DKB (A795+ SPCC)</p>	Packing and dust seal of nitrile rubber are used.
 <p>OUHR (A505) WR (12RS)</p>	Packings of nitrile rubber are used.	 <p>IUIS (U801) DKBI (U801+ SPCC)</p>	DKBI with high dust proof characteristics is used for dust seals.
 <p>USH (A505) WR (12RS)</p>	Because of less severe operating condition, O rings are mostly used, but USH packings are recommended to improve durability.	—	—
 <p>WR (12RS) SPGW (19YF+A980+ 12NM or 80NP)</p>	SPGW is used in high impact pressure and for durability.	 <p>SPN (19YF+ A980) IUIS (U641) BRT2 (19YF) DKBI (U801+ SPCC)</p> <p>Drain : To the oil tank</p>	SPN is used for buffer rings to reduce high impact pressure. Return leaked oil (oil film) into the oil tank via the drain.

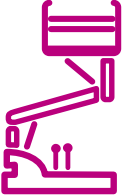
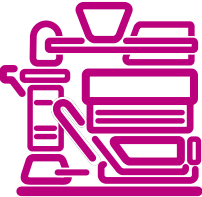
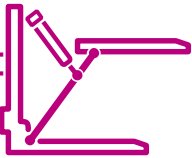
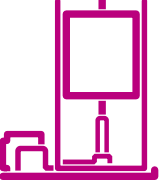

Application Examples by Equipment

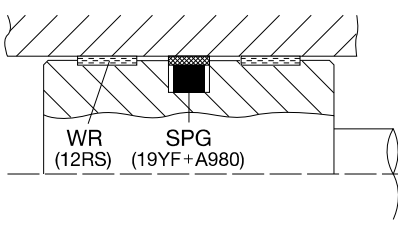
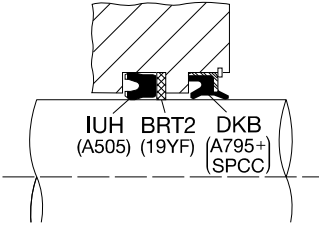
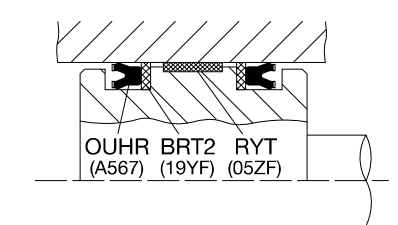
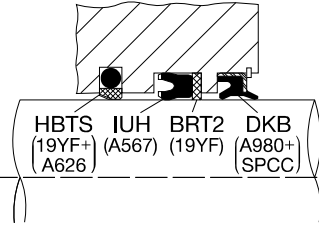
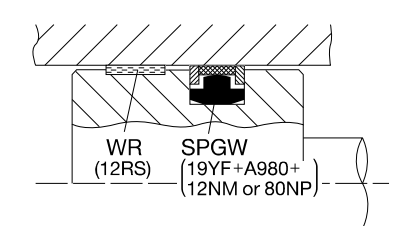
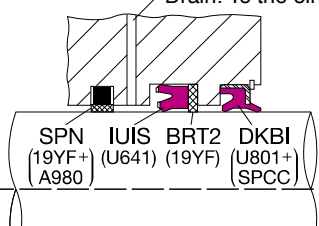
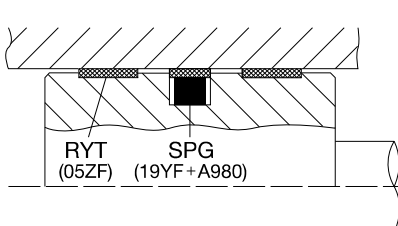
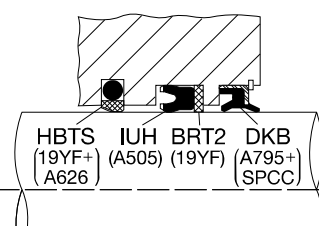
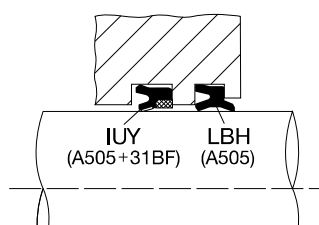
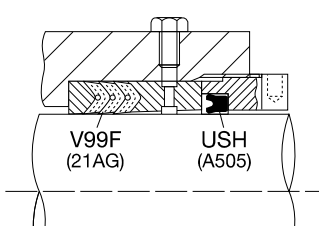
Equipment	Application	Operating condition
 <p>Robot</p>	—	0 ~ 21MPa -10 ~ 80°C
 <p>Lift</p>	—	0 ~ 21MPa -30 ~ 80°C
 <p>Injection molding machine</p>	—	0 ~ 31MPa -10 ~ 100°C
 <p>Multi stories parking</p>	—	0 ~ 14MPa -30 ~ 100°C
 <p>Hydraulic elevator</p>	—	0 ~ 5MPa -20 ~ 80°C
 <p>Plunger pump</p>	—	0 ~ 14MPa -10 ~ 80°C

Piston sealing system	Feature	Rod sealing system	Feature
 <p>WR (12RS) SPG (19YF+A980)</p>	<p>High durability SPG is used. Two WR are used to prevent scoring between the piston head and the cylinder tube that can be caused by high lateral load typical for such operating condition.</p>	 <p>IUH BRT2 DKB (A505) (19YF) (A795+ SPCC)</p>	<p>Packing and dust seal of nitrile rubber are used.</p>
 <p>OUHR BRT2 RYT (A567) (19YF) (05ZF)</p>	<p>OUHR with stick slip proof characteristics is used considering the operating condition that requires to keep working pressure for a long time. 05ZF having small friction resistance is used for wear ring material.</p>	 <p>HBTS IUH BRT2 DKB (19YF+ A626) (A567) (19YF) (A980+ SPCC)</p>	<p>HBTS is used to prevent stick slip.</p>
 <p>WR (12RS) SPGW (19YF+A980+ 12NM or 80NP)</p>	<p>SPGW is used since such operating conditions mainly performed under high pressure require the durability. This packing has also excellent durability for the operations requiring extremely short strokes.</p>	 <p>SPN IUIS BRT2 DKBI (19YF+ A980) (U641) (19YF) (U801+ SPCC)</p> <p>Drain: To the oil tank</p>	<p>SPN is used for buffer rings to reduce high impact pressure. Return leaked oil (oil film) into the oil tank via the drain.</p>
 <p>RYT (05ZF) SPG (19YF+A980)</p>	<p>High durability SPG is used. 05ZF having small friction resistance is used for wear ring material.</p>	 <p>HBTS IUH BRT2 DKB (19YF+ A626) (A505) (19YF) (A795+ SPCC)</p>	<p>HBTS is used to prevent stick slip.</p>
<p>—</p>	<p>—</p>	 <p>IUY LBH (A505+31BF) (A505)</p>	<p>IUY (of special shape) is used for packing to prevent stick slip. Rareflon is molded on to the IUY lip.</p>
<p>—</p>	<p>—</p>	 <p>V99F USH (21AG) (A505)</p>	<p>Fabric reinforced rubber V packings are used because in such operating conditions, fluids with poor lubricity, such as water and agricultural chemicals are handled and the frequency of operation is high. When pressure and frequency of operation are low, rubber V packings can be used.</p>

D
 APPLICATION
 EXAMPLES OF
 NOK PACKING

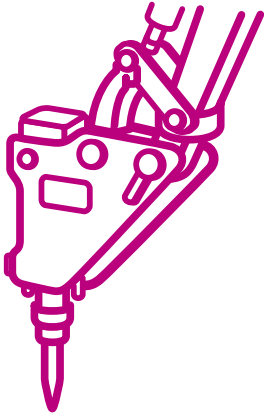
Application Examples by Equipment

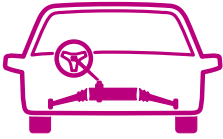
Equipment	Application	Operating condition
 <p>Hydraulic breaker</p>	—	0 ~ 17MPa -30 ~ 100°C
	—	0 ~ 18MPa -30 ~ 100°C
 <p>Operation valve</p>	—	0 ~ 0.3MPa -30 ~ 100°C
 <p>Power steering</p>	—	0 ~ 8MPa -30 ~ 100°C

Magnified view of sealing system		Feature
<p>Gas chamber</p> <p>ISI (U801)</p> <p>ISI (U801)</p> <p>Chisel side</p>	<p>ISI are used in parallel because of high speed and high pressure. Iron rubber is used for rubber material because of severe operating conditions.</p>	
<p>Gas chamber</p> <p>XRI (U563)</p> <p>HBTS (19YF+ A626)</p> <p>HBTS (19YF+ A626)</p> <p>HBY (U641+ 12NM or 80NP)</p> <p>ISI (U801)</p> <p>DSI (U801)</p> <p>Chisel side</p>	<p>HBY is used for upper hydraulic seals to reduce the friction. HBTS is also used to absorb impact pressure and reduce the friction. XRI with high wear resistance characteristics is used for gas seals to prevent oil scraping off from the gas chamber.</p>	
<p>SVY (A216+31BF+SPCC+SWP)</p>	<p>SVY is used for low friction and high lip followability to eccentricity. This packing is flat metal case type with dust lip for easy seal replacement.</p>	
<p>SPGO (19YF+A305)</p> <p>SCJY (A297+60NP+SPCC+SWP)</p>	<p>Low friction SPGO is used for the piston rings to improve system response. O ring is used for back ring to make compact the piston unit. For rod seals, oil seal SCJY with backup ring for high pressure operation is used. This seal has low friction resistance and high sealing ability.</p>	

Application Examples by Equipment

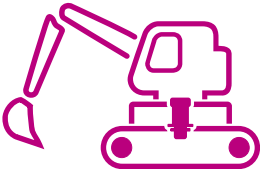
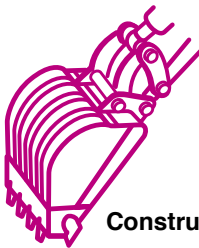
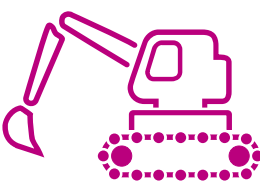
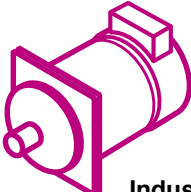
Equipment	Application	Operating condition
 <p>Construction equipment</p>	Center swivel joint	0 ~ 34MPa -30 ~ 100°C
 <p>Construction equipment</p>	Link pin Hinge pin	— -30 ~ 100°C
 <p>Construction equipment</p>	Crawler belt pin	— -30 ~ 80°C
 <p>Industrial equipment</p>	Pump Motor Reduction unit	Surge pressure: Max 2MPa -16 ~ 120°C

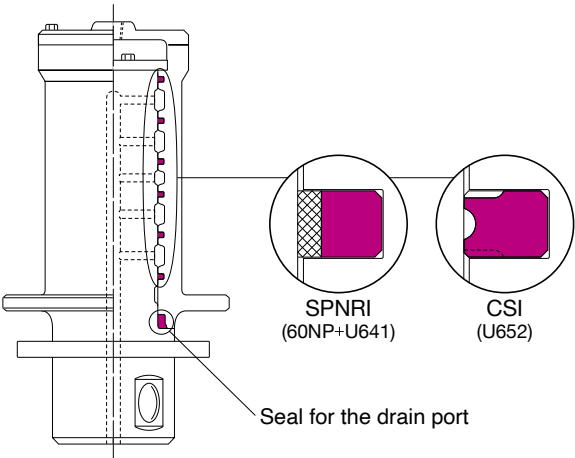
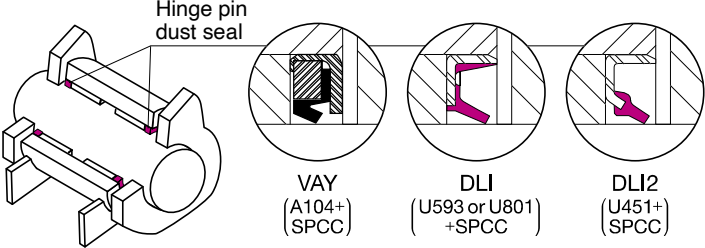
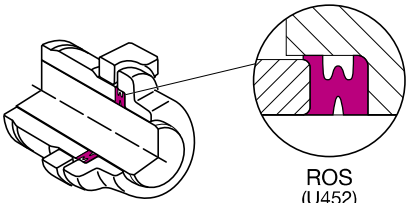
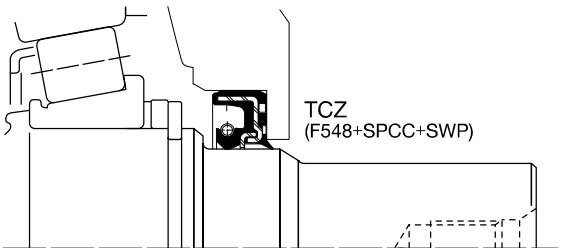
Magnified view of sealing system	Feature
 <p>SPNRI (60NP+U641)</p> <p>CSI (U652)</p> <p>Seal for the drain port</p>	<p>The seal fitting groove is mainly provided on the rotor side. CSI or SPNRI is used for each oil port seal. These packings have high durability and sealing ability. For the sealing of drain ports, oil seal or o-ring for high pressure is mainly used. This seal is used also as a dust seal.</p>
 <p>Hinge pin dust seal</p> <p>VAY (A104+ SPCC)</p> <p>DLI (U593 or U801 +SPCC)</p> <p>DLI2 (U451+ SPCC)</p>	<p>DLI2, DLI or VAY is used to protect the bearings from dust. Grease draining mechanism should be provided for periodical grease replacement.</p>
 <p>ROS (U452)</p>	<p>ROS is used for this oscillating application, in order to retain lubricant oil and prevent entry of dust. The sealing characteristics are good due to excellent abrasion resistance, even under the severe condition that mud, earth and sand, etc. exist.</p>
 <p>TCZ (F548+SPCC+SWP)</p>	<p>TCZ is used for high pressure application.</p>

SPECIAL PACKINGS FOR PISTON SEALS Page

ODI	59
OSI	67
OUIS	70
OUHR	72
OKH+BRL	74
SPGO	77
SPG	81
SPGM	86
SPGN	88
SPGW	91
SPGC	94
CPI	98
CPH	100

SPECIAL PACKINGS FOR ROD SEALS

IDI	103
ISI	111
IUIS	114
IUH	117
UNI	120
SPNO	123
SPN	126
SPNS	129
SPNC	133

PACKINGS FOR BOTH PISTON AND ROD SEALS

UPI	137
USI	143
UPH	147
USH	155
V99F	159
V96H	165

DUST SEALS FOR RECIPROCAL MOVEMENT

DKI	171
DWI	174
DWIR	176
DKBI	178
DKBI3	180
DKBZ	182
DKB	184
DKH	186
DSI	189
LBI	192
LBH	195
LBHK	198
DSPB	201

DUST SEALS FOR OSCILLATING AND ROTATING MOVEMENT

DLI	204
DLI2	206

BUFFER RINGS FOR RECIPROCAL MOVEMENT

HBY	208
HBTS	211

RELATING PRODUCTS FOR HYDRAULIC EQUIPMENT

RYT	214
WR (12RS)	217
WR (88RS)	221
KZT	224



DIMENSION TABLE

About ordering NOK packing

Please place your order with the nearest NOK branch, sales office, or agent for NOK packing.

- 1** Please designate the NOK part number, type and size with your order. (Specifying methods are described in each dimension table.)
- 2** If you require packings that are not listed in the dimension tables, or have any difficulty selecting packings because of special operating condition, consult with NOK branch, sales office, or agent.
- 3** If you require type and size that are not listed in the dimension tables or material (rubber, plastic or metal case) other than standard materials for each type, new molding tool may be necessary.

Please inquire about availability and price at your nearest NOK branch, sales office, or agent.

ODI TYPE

SPECIAL PACKINGS FOR PISTON SEALS IRON RUBBER (PUR)



● Please designate NOK Part number and type & size on your order.

(Example) Order for the packing as a single piece

· Type Dimensions	<u>ODI</u>	<u>18</u>	<u>8</u>	<u>7.5</u>	
	└─ Type Sign	└─ Nominal Size of Packing described in order of outer diameter(D), inner diameter(d), and height(h)			
· Part Number	FU2150H0				

※ When placing orders for backup rings used in combination with packing, designate the NOK part number and the model size.

· Type Dimensions	<u>BRT3</u>	<u>8</u>	<u>18</u>	<u>2</u>	
	└─ Type Sign	└─ Nominal Size of Backup ring described in order of inner diameter(d), outer diameter(D), and thickness(t)*			
· Part Number	GN0725V0				*t = H _B - H _A (Housing dimensions)

● Please check the application range on pages 14 and 15 before selecting the type.

Material	NOK U801
-----------------	----------

ODI TYPE SPECIAL PACKINGS FOR PISTON SEALS

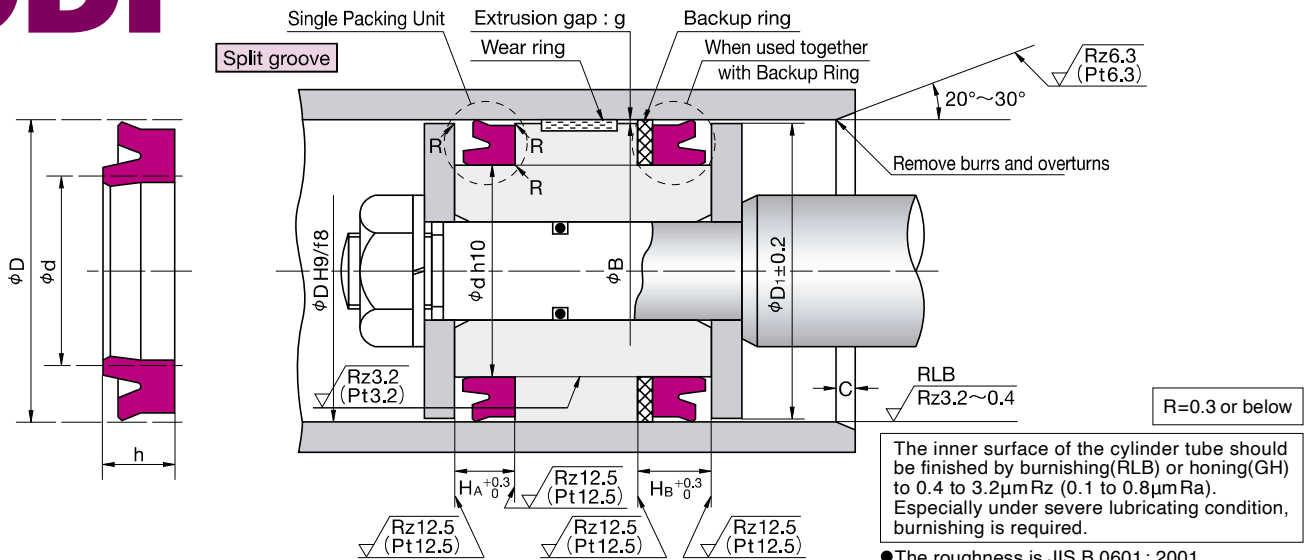

Nominal Size of Packing, and Housing dimensions							Packing Part Number	Combination Backup Ring Part Number	
D	d	h	H _A	H _B	ϕD_1	C		BRT3 (Endless) 19YF	BRN3 (Endless) 80NP
18	8	7.5	8.5	10.5	17	2.5	FU2150H0	GN0725V0	GN9101O1
19.2	11.2	5	5.7	7.7	18.2	2.5	※FU0202H0	GN7236V0	GN9792O0
20	10	6	7	9	19	2.5	※FU0205H0	GN0733V0	GN9102O1
20	10	7.5	8.5	10.5	19	2.5	FU0206H0	GN0733V0	GN9102O1
20	10	8	9	11	19	2.5	FU0207H0	GN0733V0	GN9102O1
20	12	5	5.7	7.7	19	2.5	※FU0208H0	GN7237V0	GN9793O0
22	14	5	5.7	7.7	21	2.5	※FU0242H0	GN7238V0	GN9794O0
24	14	7.5	8.5	10.5	23	3.5	FU2151H0	GN0745V0	GN9103O1
25	15	6	7	9	24	3.5	※FU0273H0	GN0749V0	GN9738O1
25	15	8	9	11	24	3.5	FU0274H0	GN0749V0	GN9738O1
25	17	5	5.7	7.7	24	3.5	※FU0275H0	GN7239V0	GN9795O0
26	16	7.5	8.5	10.5	25	3.5	FU2152H0	GN0751V0	GN9105O1
26	18	5	5.7	7.7	25	3.5	※FU0310H0	GN6377V0	GN9106O1
28	15	10	11	13	27	3.5	FU2153H0	GN6445V0	GN9104O1
28	20	5	5.7	7.7	27	2	※FU2138H0	GN6447V0	GN9108O1
30	20	5	5.7	7.7	29	3.5	※FU0351H0	GN0762V0	GN9109O1
30	20	6	7	9	29	3.5	※FU0352H0	GN0762V0	GN9109O1
30	20	8	9	11	29	3.5	FU0353H0	GN0762V0	GN9109O1
30	22.4	5	5.7	7.7	29	2	※FU2139H0	GN6450V0	GN9112O1
31	18	10	11	13	30	3.5	FU2154H0	GN6446V0	GN9107O1
31.5	18.5	8	9	11	30.5	3.5	FU0377H0	GN7240V0	GN9796O0
31.5	18.5	10	11	13	30.5	3.5	FU0378H0	GN7240V0	GN9796O0
31.5	21.5	6	7	9	30.5	3.5	※FU0379H0	GN0767V0	GN9797O0
31.5	21.5	8	9	11	30.5	3.5	FU0380H0	GN0767V0	GN9797O0
31.5	23.5	5	5.7	7.7	30.5	2	※FU0381H0	GN6452V0	GN9114O1
33	20	10	11	13	32	3.5	FU2155H0	GN6448V0	GN9110O1
33	25	5	5.7	7.7	32	2	※FU2140H0	GN6665V0	GN9786O1
35	22	10	11	13	34	3.5	FU2156H0	GN6449V0	GN9111O1
35	25	6	7	9	34	3.5	※FU0418H0	GN0781V0	GN9115O1
35	25	8	9	11	34	3.5	FU0419H0	GN0781V0	GN9115O1
35.4	22.4	10	11	13	34.4	3.5	FU2157H0	GN6017V0	GN9798O0
35.5	22.5	8	9	11	34.5	3.5	FU0446H0	GN7241V0	GN9799O0
35.5	22.5	10	11	13	34.5	3.5	FU0447H0	GN7241V0	GN9799O0
35.5	25.5	6	7	9	34.5	3.5	※FU0448H0	GN6454V0	GN9117O1
35.5	25.5	8	9	11	34.5	3.5	FU0449H0	GN6454V0	GN9117O1
38	25	10	11	13	37	3.5	FU0466H0	GN6453V0	GN9116O1
40	25	9	10	12	39	3.5	FU0485H0	GN6591V0	GN9800O0
40	25	10	11	13	39	3.5	FU0486H0	GN6591V0	GN9800O0
40	27	8	9	12	39	3.5	FU0488H0	GN6455V0	GN9118O1
40	27	10	11	14	39	3.5	FU0489H0	GN6455V0	GN9118O1
40	30	8	9	12	39	3.5	FU0491H0	GN6361V0	GN9122O1
41	28	10	11	14	40	3.5	FU2158H0	GN6458V0	GN9121O1

※ The resisting pressure limit applies to the OSI type.

HOW TO DETERMINE B DIMENSION

■ When using backup ring

Please determine B dimension according to the table below. If you require smaller B dimension because of the cylinder configuration, please consult NOK.

Maximum Service Pressure	14MPa	21MPa	35MPa
Material of Backup ring	19YF		
B Dimension	$B \geq \phi D - 1.0$	$B \geq \phi D - 0.5$	$B \geq \phi D - 0.2$
Maximum Service Pressure	35MPa	42MPa	70MPa
Material of Backup ring	80NP		
B Dimension	$B \geq \phi D - 0.8$	$B \geq \phi D - 0.4$	$B \geq \phi D - 0.2$

■ When not using backup ring

To determine B dimension, please refer to the graph in the right for the maximum extrusion gap (one side) considering the eccentricity of operating condition of the piston.

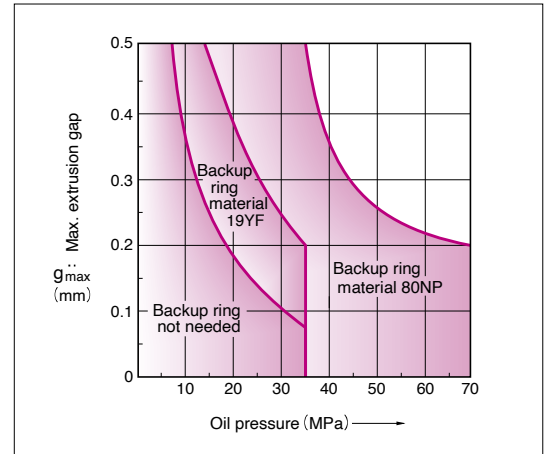

Nominal Size of Packing, and Housing dimensions							Packing Part Number	Combination Backup Ring Part Number	
D	d	h	H _A	H _B	φD ₁	C		BRT3 (Endless)	BRN3 (Endless)
								19YF	80NP
43	30	10	11	14	42	3.5	FU2159H0	GN6459V0	GN9123O1
44.5	31.5	10	11	14	43.5	3.5	FU2160H0	GN6461V0	GN9125O1
45	30	9	10	13	44	3.5	FU0559H0	GN7061V0	GN9801O0
45	30	10	11	14	44	3.5	FU0560H0	GN7061V0	GN9801O0
45	32	8	9	12	44	3.5	FU0561H0	GN7242V0	GN9802O0
45	32	10	11	14	44	3.5	FU0562H0	GN7242V0	GN9802O0
45	35	8	9	12	44	3.5	FU0564H0	GN6463V0	GN9127O1
50	34	10	11	14	49	4	FU0608H0	GN6462V0	GN9126O1
50	34	12	13	16	49	4	FU0609H0	GN6462V0	GN9126O1
50	35	9	10	13	49	4	FU0610H0	GN0816V0	GN9128O1
50	35	10	11	14	49	4	FU0611H0	GN0816V0	GN9128O1
50	35	12	13	16	49	4	FU2161H0	GN0816V0	GN9128O1
50	40	8	9	12	49	4	FU0614H0	GN6465V0	GN9131O1
51.5	35.5	12	13	16	50.5	4	FU2162H0	GN6330V0	GN9130O1
55	40	9	10	13	54	4	FU0689H0	GN6759V0	GN9948O0
55	40	10	11	14	54	4	FU0690H0	GN6759V0	GN9948O0
55	45	8	9	12	54	4	FU0693H0	GN6467V0	GN9133O1
56	40	10	11	14	55	4	FU0716H0	GN6466V0	GN9132O1
56	40	12	13	16	55	4	FU0717H0	GN6466V0	GN9132O1
56	41	9	10	13	55	4	FU0718H0	GN0835V0	GN9949O0
56	41	10	11	14	55	4	FU0719H0	GN0835V0	GN9949O0
56	46	8	9	12	55	4	FU0721H0	GN7243V0	GN9782O1
60	45	9	10	13	59	4	FU0740H0	GN0845V0	GN9950O0
60	45	10	11	14	59	4	FU0741H0	GN0845V0	GN9950O0
60	50	8	9	12	59	4	FU0743H0	GN6302V0	GN9138O1
61	45	12	13	16	60	4	FU2163H0	GN6469V0	GN9135O1
63	47	10	11	14	62	4	FU0779H0	GN6471V0	GN9137O1
63	47	12	13	16	62	4	FU0780H0	GN6471V0	GN9137O1
63	48	9	10	13	62	4	FU0781H0	GN0853V0	GN9951O0
63	48	10	11	14	62	4	FU0782H0	GN0853V0	GN9951O0
63	53	8	9	12	62	4	FU0785H0	GN6413V0	GN9140O1
65	50	9	10	13	64	4	FU0804H0	GN6439V0	GN9952O0
65	50	10	11	14	64	4	FU0805H0	GN6439V0	GN9952O0
65	55	8	9	12	64	4	FU0808H0	GN6472V0	GN9141O1
66	50	12	13	16	65	4	FU2164H0	GN6329V0	GN9139O1
69	53	12	13	16	68	4	FU0836H0	GN7008V0	GN9803O0
70	50	12	13	16	69	5	FU0842H0	GN6592V0	GN9529O0
70	55	9	10	13	69	5	FU0844H0	GN6408V0	GN9804O0
70	55	10	11	14	69	5	FU0845H0	GN6408V0	GN9804O0
70	60	8	9	12	69	5	FU0847H0	GN6444V0	GN9144O1

ODI TYPE SPECIAL PACKINGS FOR PISTON SEALS

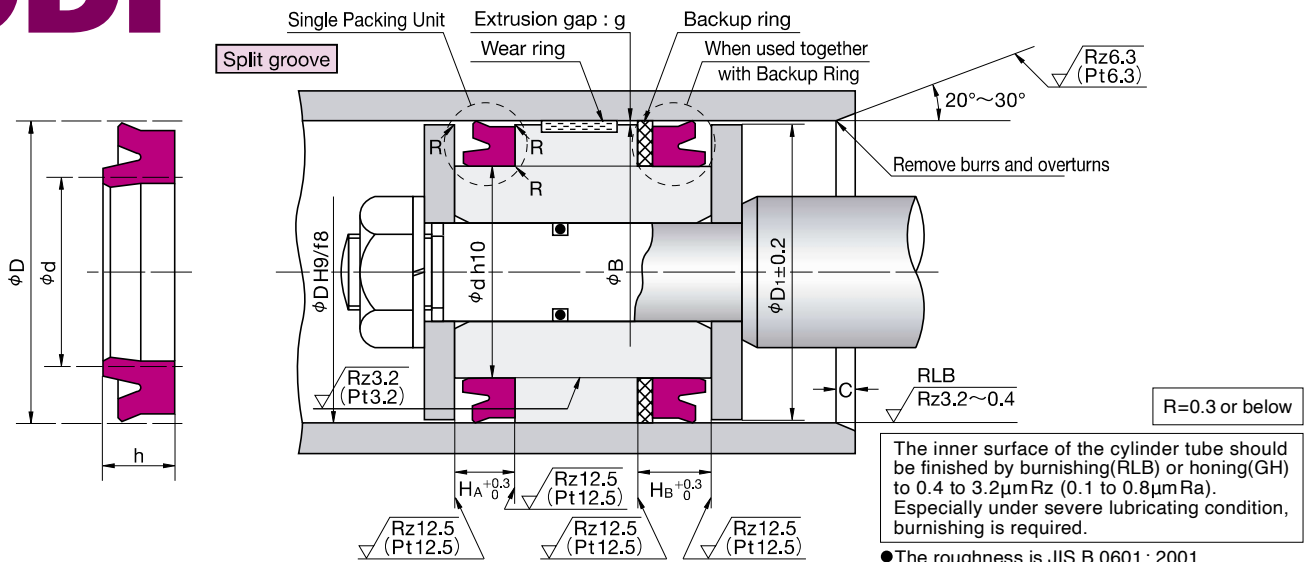

● The roughness is JIS B 0601 : 2001.
When regulation length cannot be kept, apply Pt.

Nominal Size of Packing, and Housing dimensions							Packing Part Number	Combination Backup Ring Part Number	
D	d	h	H _A	H _B	φD ₁	C		BRT3 (Endless) 19YF	BRN3 (Endless) 80NP
71	51	12	13	16	70	5	FU0872H0	GN0862V0	GN9805O0
71	55	10	11	14	70	5	FU0873H0	GN6473V0	GN9142O1
71	55	12	13	16	70	5	FU0874H0	GN6473V0	GN9142O1
71	56	9	10	13	70	5	FU0875H0	GN7247V0	GN9806O0
71	56	10	11	14	70	5	FU0876H0	GN7247V0	GN9806O0
71	61	8	9	12	70	5	FU0878H0	GN7248V0	GN9783O1
75	55	12	13	16	74	5	FU0894H0	GN7249V0	GN9807O0
75	60	9	10	13	74	5	FU0895H0	GN6363V0	GN9808O0
75	60	10	11	14	74	5	FU0896H0	GN6363V0	GN9808O0
75	65	8	9	12	74	5	FU0898H0	GN6479V0	GN9149O1
76	60	12	13	16	75	5	FU2165H0	GN6476V0	GN9146O1
80	60	12	13	16	79	5	FU0929H0	GN0886V1	GN9953O0
80	64	10	11	14	79	5	FU0931H0	GN6478V0	GN9148O1
80	64	12	13	16	79	5	FU0932H0	GN6478V0	GN9148O1
80	65	9	10	13	79	5	FU0933H0	GN6364V0	GN9754O1
80	65	10	11	14	79	5	FU0934H0	GN6364V0	GN9754O1
80	70	8	9	12	79	5	FU0937H0	GN6362V1	GN9092O1
85	65	12	13	16	84	5	FU0974H0	GN0899V0	GN9810O0
85	70	9	10	13	84	5	FU0977H0	GN6442V0	GN9411O0
85	70	10	11	14	84	5	FU0978H0	GN6442V0	GN9411O0
85	75	8	9	12	84	5	FU0980H0	GN6729V0	GN9241O1
90	70	12	13	16	89	5	FU1014H0	GN0910V0	GN9151O1
90	70	15	16	19	89	5	FU1015H0	GN0910V0	GN9151O1
90	75	9	10	13	89	5	FU1017H0	GN6443V0	GN9757O1
90	75	10	11	14	89	5	FU1018H0	GN6443V0	GN9757O1
90	80	8	9	12	89	5	FU1020H0	GN6483V0	GN9155O1
95	75	12	13	16	94	5	FU1045H0	GN0920V0	GN9154O1
95	75	15	16	19	94	5	FU1046H0	GN0920V0	GN9154O1
95	80	9	10	13	94	5	FU1047H0	GN6898V0	GN9582O0
95	80	10	11	14	94	5	FU1048H0	GN6898V0	GN9582O0
100	80	12	13	16	98	5	FU1072H0	GN0927V0	GN9156O1
100	80	15	16	19	98	5	FU1074H0	GN0927V0	GN9156O1
100	85	10	11	14	98	5	FU1079H0	GN6484V0	GN9091O1
105	85	15	16	19	103	5	FU2166H0	GN0932V0	GN9157O1
110	90	12	13	16	108	5	FU1149H0	GN0939V0	GN9159O1
110	90	15	16	19	108	5	FU1150H0	GN0939V0	GN9159O1
110	95	10	11	14	108	5	FU1153H0	GN6486V0	GN9160O1
112	92	12	13	16	110	5	FU1174H0	GN0940V0	GN9811O0
112	92	15	16	19	110	5	FU1175H0	GN0940V0	GN9811O0
112	97	9	10	13	110	5	FU1176H0	GN7250V0	GN9812O0
112	97	10	11	14	110	5	FU1177H0	GN7250V0	GN9812O0

E DIMENSION ODI

HOW TO DETERMINE B DIMENSION

■ When using backup ring

Please determine B dimension according to the table below. If you require smaller B dimension because of the cylinder configuration, please consult NOK.

Maximum Service Pressure	14MPa	21MPa	35MPa
Material of Backup ring	19YF		
B Dimension	$B \geq \phi D - 1.0$	$B \geq \phi D - 0.5$	$B \geq \phi D - 0.2$
Maximum Service Pressure	35MPa	42MPa	70MPa
Material of Backup ring	80NP		
B Dimension	$B \geq \phi D - 0.8$	$B \geq \phi D - 0.4$	$B \geq \phi D - 0.2$

■ When not using backup ring

To determine B dimension, please refer to the graph in the right for the maximum extrusion gap (one side) considering the eccentricity of operating condition of the piston.

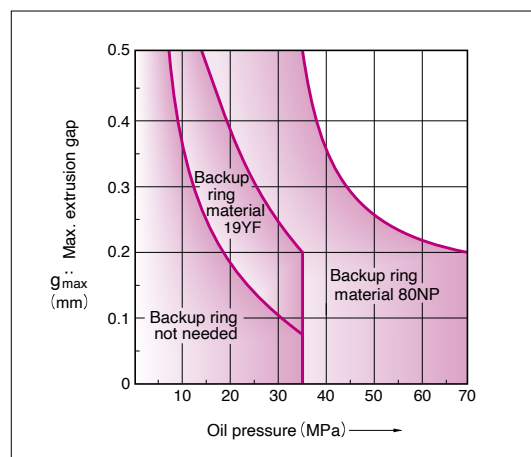

Nominal Size of Packing, and Housing dimensions							Packing Part Number	Combination Backup Ring Part Number	
D	d	h	H _A	H _B	φD ₁	C		BRT3 (Endless)	BRN3 (Endless)
								19YF	80NP
115	95	15	16	19	113	5	FU2167H0	GN0945V0	GN9161O1
120	100	12	13	16	118	5	FU1210H0	GN0952V0	GN9164O1
120	100	15	16	19	118	5	FU1211H0	GN0952V0	GN9164O1
120	105	10	11	14	118	5	FU1213H0	GN6684V0	GN9589O1
125	105	12	13	16	123	5	FU1243H0	GN0959V0	GN9165O1
125	105	15	16	19	123	5	FU1244H0	GN0959V0	GN9165O1
125	105	16	17	20	123	5	FU1245H0	GN0959V0	GN9165O1
125	110	9	10	13	123	5	FU1247H0	GN6761V0	GN9430O1
125	110	10	11	14	123	5	FU1248H0	GN6761V0	GN9430O1
130	110	12	13	16	128	5	FU1274H0	GN6790V0	GN9694O0
130	110	15	16	19	128	5	FU1275H0	GN6790V0	GN9694O0
130	110	16	17	20	128	5	FU1276H0	GN6790V0	GN9694O0
130	115	10	11	14	128	5	FU1279H0	GN6741V0	GN9274O1
132	112	15	16	19	130	5	FU2168H0	GN0970V0	GN9168O1
140	120	12	13	16	138	5	FU1316H0	GN0982V0	GN9169O1
140	120	15	16	19	138	5	FU1317H0	GN0982V0	GN9169O1
140	120	16	17	20	138	5	FU1318H0	GN0982V0	GN9169O1
140	125	10	11	14	138	5	FU1321H0	GN6491V0	GN9170O1
150	125	19	20	23	148	6.5	FU2169H0	GN6135V0	GN9171O1
150	125	20	21	24	148	6.5	FU1351H0	GN6135V0	GN9171O1
150	130	12	13	16	148	6.5	FU1352H0	GN6925V0	GN9335O1
150	130	16	17	20	148	6.5	FU1354H0	GN6925V0	GN9335O1
150	135	10	11	14	148	6.5	FU1357H0	GN6666V0	GN9539O1
157	132	20	21	24	155	6.5	FU1909H0	GN7013V0	GN9813O0
160	135	19	20	23	158	6.5	FU2170H0	GN6492V0	GN9172O1
160	135	20	21	24	158	6.5	FU1398H0	GN6492V0	GN9172O1
160	140	12	13	16	158	6.5	FU1399H0	GN1002V0	GN9668O0
160	140	16	17	20	158	6.5	FU1402H0	GN1002V0	GN9668O0
160	145	10	11	14	158	6.5	FU1405H0	GN6495V0	GN9175O1
165	140	19	20	23	163	6.5	FU1426H0	GN6494V0	GN9174O1
165	140	20	21	24	163	6.5	FU2186H0	GN6494V0	GN9174O1
170	145	19	20	23	168	6.5	FU1436H0	GN6496V0	GN9176O1
170	145	20	21	24	168	6.5	FU1437H0	GN6496V0	GN9176O1
170	150	12	13	16	168	6.5	FU1438H0	GN1011V0	GN9672O1
170	150	16	17	20	168	6.5	FU1440H0	GN1011V0	GN9672O1
170	155	10	11	15	168	6.5	FU1442H0	GN6498V0	GN9178O1
180	155	16	17	21	178	6.5	FU1475H0	GN1016V0	GN9179O1
180	155	19	20	24	178	6.5	FU2171H0	GN1016V0	GN9179O1
180	155	20	21	25	178	6.5	FU1476H0	GN1016V0	GN9179O1
180	160	12	13	17	178	6.5	FU1478H0	GN6905V0	GN9814O0
180	160	16	17	21	178	6.5	FU1479H0	GN6905V0	GN9814O0
180	165	10	11	15	178	6.5	FU1482H0	GN6500V0	GN9182O1

ODI TYPE SPECIAL PACKINGS FOR PISTON SEALS

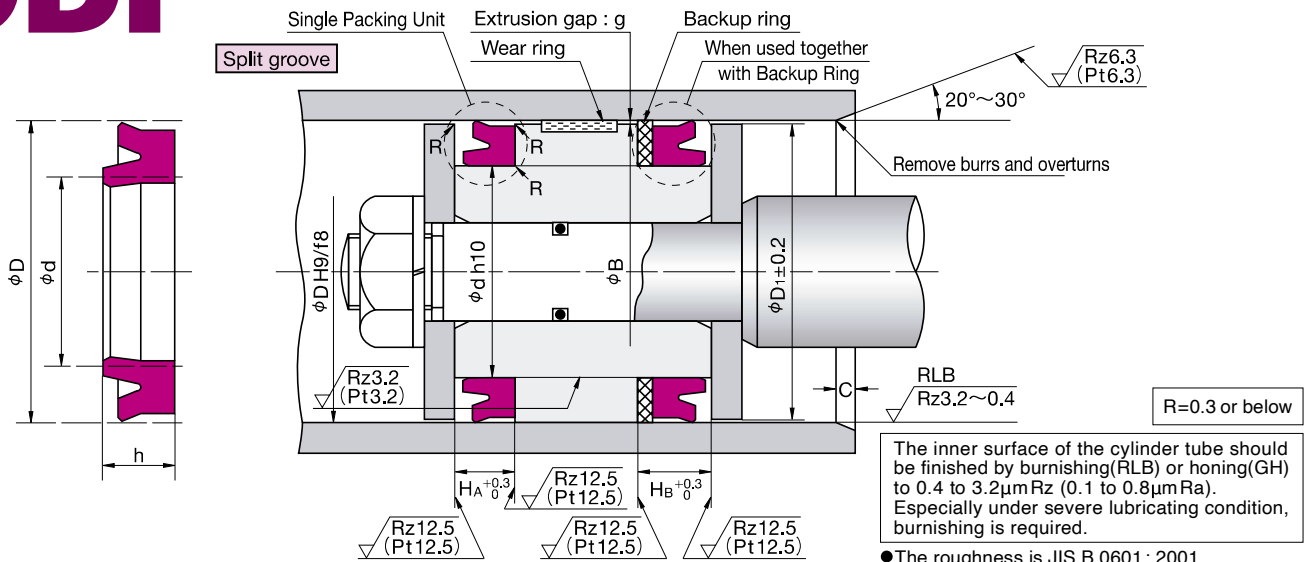

Nominal Size of Packing, and Housing dimensions							Packing Part Number	Combination Backup Ring Part Number	
D	d	h	H _A	H _B	φD ₁	C		BRT3 (Endless) 19YF	BRN3 (Endless) 80NP
185	160	19	20	24	183	6.5	FU2172H0	GN1020V0	GN9181O1
185	160	20	21	25	183	6.5	FU2187H0	GN1020V0	GN9181O1
190	165	16	17	21	188	6.5	FU1507H0	GN1023V0	GN9815O0
190	165	20	21	25	188	6.5	FU1508H0	GN1023V0	GN9815O0
190	170	12	13	17	188	6.5	FU1509H0	GN6985V0	GN9816O0
190	170	16	17	21	188	6.5	FU1510H0	GN6985V0	GN9816O0
190	175	10	11	15	188	6.5	FU1512H0	GN6503V0	GN9185O1
200	175	16	17	21	198	6.5	FU1536H0	GN1031V0	GN9186O1
200	175	19	20	24	198	6.5	FU2173H0	GN1031V0	GN9186O1
200	175	20	21	25	198	6.5	FU1538H0	GN1031V0	GN9186O1
200	180	16	17	21	198	6.5	FU1540H0	GN6372V0	GN9187O1
205	180	19	20	24	203	6.5	FU2174H0	GN1035V0	GN9188O1
205	180	20	21	25	203	6.5	FU2188H0	GN1035V0	GN9188O1
210	185	16	17	21	208	6.5	FU1570H0	GN1039V0	GN9817O0
210	185	20	21	25	208	6.5	FU1571H0	GN1039V0	GN9817O0
210	190	16	17	21	208	6.5	FU1573H0	GN6505V0	GN9190O1
215	190	16	17	21	213	6.5	FU2260H0	GN1042V0	GN9818O0
220	195	16	17	21	218	6.5	FU1592H0	GN7253V0	GN9819O0
220	195	20	21	25	218	6.5	FU1593H0	GN7253V0	GN9819O0
220	200	16	17	21	218	6.5	FU1595H0	GN6276V0	GN9191O1
224	199	16	17	21	222	6.5	FU1604H0	GN1047V0	GN9820O0
224	199	20	21	25	222	6.5	FU1605H0	GN1047V0	GN9820O0
224	204	16	17	21	222	6.5	FU1607H0	GN6506V0	GN9193O1
225	200	16	17	21	223	6.5	FU1616H0	GN1050V0	GN9192O1
225	200	19	20	24	223	6.5	FU2175H0	GN1050V0	GN9192O1
225	200	20	21	25	223	6.5	FU1617H0	GN1050V0	GN9192O1
225	205	16	17	21	223	6.5	FU1619H0	GN7255V0	GN9784O1
230	205	16	17	21	228	6.5	FU1632H0	GN1053V0	GN9557O1
230	205	19	20	24	228	6.5	FU1633H0	GN1053V0	GN9557O1
230	205	20	21	25	228	6.5	FU1634H0	GN1053V0	GN9557O1
230	210	16	17	21	228	6.5	FU1636H0	GN6352V0	GN9195O1
240	215	16	17	21	238	6.5	FU1652H0	GN7256V0	GN9574O0
240	215	19	20	24	238	6.5	FU1653H0	GN7256V0	GN9574O0
240	215	20	21	25	238	6.5	FU1654H0	GN7256V0	GN9574O0
240	220	16	17	21	238	6.5	FU1656H0	GN6508V0	GN9196O1
250	225	16	17	21	248	6.5	FU1671H0	GN1065V0	GN9045O1
250	225	19	20	24	248	6.5	FU1672H0	GN1065V0	GN9045O1
250	225	20	21	25	248	6.5	FU1673H0	GN1065V0	GN9045O1
250	230	16	17	21	248	6.5	FU1676H0	GN6510V0	GN9047O1
260	235	16	17	21	258	6.5	FU1698H0	GN7257V0	GN9821O0
260	235	19	20	24	258	6.5	FU1699H0	GN7257V0	GN9821O0
260	240	16	17	21	258	6.5	FU1701H0	GN6511V0	GN9198O1

E DIMENSION ODI

HOW TO DETERMINE B DIMENSION

■ When using backup ring

Please determine B dimension according to the table below. If you require smaller B dimension because of the cylinder configuration, please consult NOK.

Maximum Service Pressure	14MPa	21MPa	35MPa
Material of Backup ring	19YF		
B Dimension	$B \geq \phi D - 1.0$	$B \geq \phi D - 0.5$	$B \geq \phi D - 0.2$

Maximum Service Pressure	35MPa	42MPa	70MPa
Material of Backup ring	80NP		
B Dimension	$B \geq \phi D - 0.8$	$B \geq \phi D - 0.4$	$B \geq \phi D - 0.2$

■ When not using backup ring

To determine B dimension, please refer to the graph in the right for the maximum extrusion gap (one side) considering the eccentricity of operating condition of the piston.

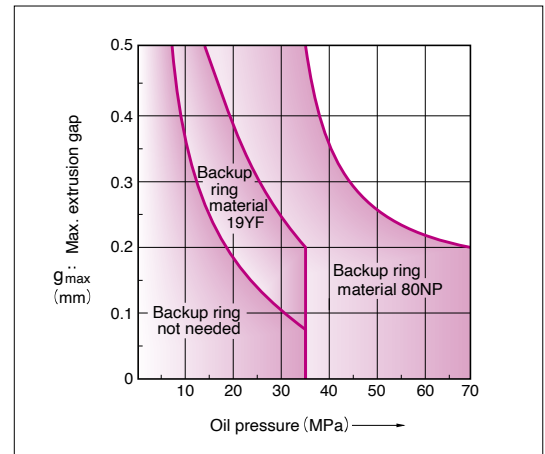

Nominal Size of Packing, and Housing dimensions							Packing Part Number	Combination Backup Ring Part Number	
D	d	h	H _A	H _B	φD ₁	C		BRT3 (Endless)	BRN3 (Endless)
								19YF	80NP
270	245	16	17	21	268	6.5	FU1715H0	GN7258V0	GN9675O0
270	245	19	20	24	268	6.5	FU1716H0	GN7258V0	GN9675O0
270	250	16	17	21	268	6.5	FU1718H0	GN6512V0	GN9199O1
275	250	19	20	24	273	6.5	FU2176H0	GN1078V0	GN9200O1
275	250	20	21	25	273	7.5	FU2189H0	GN1078V0	GN9200O1
280	250	19	20	24	278	7.5	FU1729H0	GN6197V0	GN9432O1
280	255	19	20	24	278	7.5	FU1731H0	GN6513V0	GN9201O1
290	260	19	20	24	288	7.5	FU1744H0	GN1083V0	GN9431O1
290	265	19	20	24	288	7.5	FU1746H0	GN6318V0	GN9203O1
297	265	24	25	29	295	7.5	FU2177H0	GN6515V0	GN9204O1
297	265	25	26	30	295	7.5	FU2190H0	GN6515V0	GN9204O1
300	270	19	20	24	298	7.5	FU1758H0	GN1089V0	GN9206O1
300	270	24	25	29	298	7.5	FU2178H0	GN1089V0	GN9206O1
300	270	25	26	30	298	7.5	FU1759H0	GN1089V0	GN9206O1
300	275	19	20	24	298	7.5	FU1761H0	GN6517V0	GN9207O1
312	280	24	25	29	310	7.5	FU2193H0	GN6519V0	GN9209O1
332	300	24	25	29	330	7.5	FU2194H0	GN6522V0	GN9212O1

OSI TYPE

SPECIAL PACKINGS FOR PISTON SEALS IRON RUBBER (PUR)



● Please designate NOK Part number and type & size on your order.

(Example) Order for the packing as a single piece

· Type Dimensions	OSI	35	27	5	
	└─ Type Sign	└─ Nominal Size of Packing described in order of outer diameter(D), inner diameter(d), and height(h)			
· Part Number	FU0420L0				

※ When placing orders for backup rings used in combination with packing, designate the NOK part number and the model size.

· Type Dimensions	BRT2	27	35	3	
	└─ Type Sign	└─ Nominal Size of Backup ring described in order of inner diameter(d), outer diameter(D), and thickness(t)*			
· Part Number	GN5707V0				*t = H _B - H _A (Housing dimensions)

● Please check the application range on pages 14 and 15 before selecting the type.

Material	NOK U801
-----------------	----------

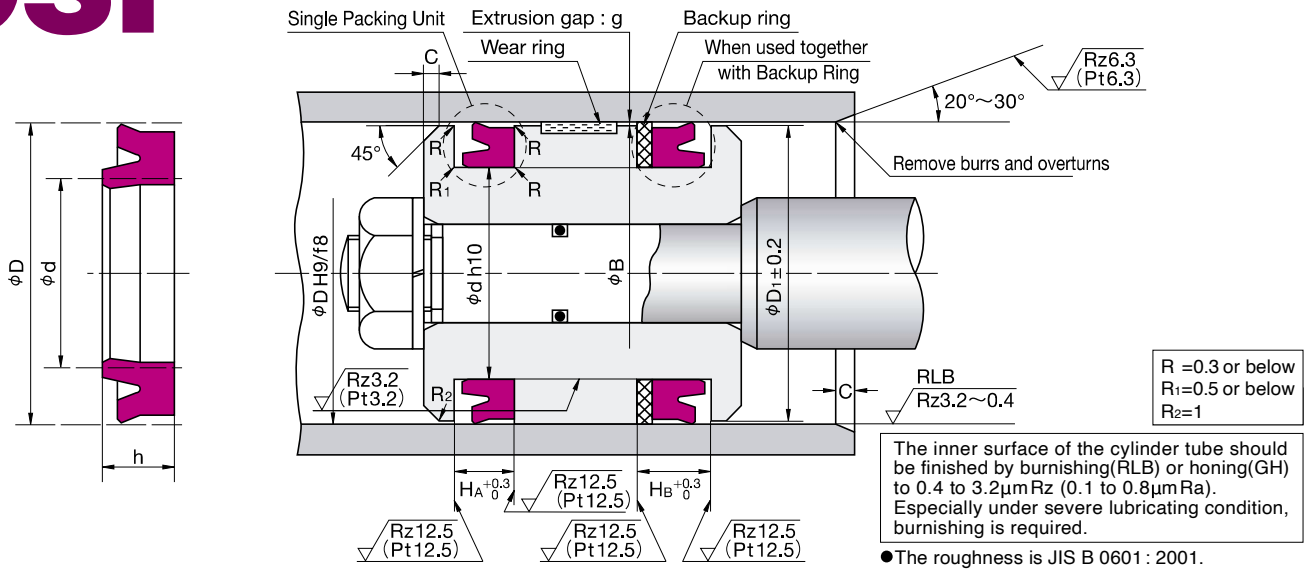

Nominal Size of Packing, and Housing dimensions							Packing Part Number	Combination Backup Ring Part Number	
D	d	h	H _A	H _B	φD ₁	C		BRT2 (Biascut) 19YF	BRN2 (Biascut) 80NP
35	27	5	5.7	8.7	34	2	FU0420L0	GN5707V0	GN9780O0
35.5	27.5	5	5.7	8.7	34.5	2	FU0450L0	GN5708V0	GN9781O0
35.5	28	5	5.7	8.7	34.5	2	FU2141L0	GN4791V0	GN9119O0
40	30	6	7	10	39	2.5	FU0490L0	GN4794V0	GN9122O0
41.5	31.5	6	7	10	40.5	2.5	FU2142L0	GN4796V0	GN9124O0
45	35	6	7	10	44	2.5	FU0563L0	GN4799V0	GN9127O0
45	35.5	6	7	10	44	2.5	FU2143L0	GN4801V0	GN9129O0
50	40	6	7	10	49	2.5	FU0613L0	GN4050V0	GN9131O0
55	45	6	7	10	54	2.5	FU0692L0	GN4804V0	GN9133O0
56	45	7	8	11	55	2.5	FU2144L0	GN4805V0	GN9134O0
56	46	6	7	10	55	2.5	FU0720L0	GN5709V0	GN9782O0
60	50	6	7	10	59	2.5	FU0742L0	GN4335V0	GN9138O0
63	53	6	7	10	62	2.5	FU0784L0	GN4693V0	GN9140O0
65	55	6	7	10	64	2.5	FU0807L0	GN4810V0	GN9141O0
66	56	6	7	10	65	2.5	FU0825L0	GN4766V0	GN9143O0
70	60	6	7	10	69	2.5	FU0846L0	GN4676V0	GN9144O0
71	60	7	8	11	70	2.5	FU2145L0	GN4812V0	GN9145O0
71	61	6	7	10	70	2.5	FU0877L0	GN4629V0	GN9783O0
73	63	6	7	10	72	2.5	FU0889L0	GN4814V0	GN9147O0
75	65	6	7	10	74	2.5	FU0897L0	GN4816V0	GN9149O0
77	67	6	7	10	76	2.5	FU0922L0	GN4697V0	GN9150O0
80	70	6	7	10	79	2.5	FU0936L0	GN4651V0	GN9092O0
80	71	6	7	10	79	2.5	FU2146L0	GN4818V0	GN9152O0
85	75	6	7	10	84	2.5	FU0979L0	GN4692V0	GN9241O0
90	80	6	7	10	89	2.5	FU1019L0	GN4820V0	GN9155O0
100	85	9	10	13	98	4	FU1078L0	GN4687V0	GN9091O0
105	90	9	10	13	103	4	FU1120L0	GN4698V0	GN9158O0
110	95	9	10	13	108	4	FU1152L0	GN4822V0	GN9160O0
112	98	8.5	9.5	12.5	110	4	FU2147L0	GN4824V0	GN9162O0
115	100	9	10	13	113	4	FU1193L0	GN4512V0	GN9163O0
120	105	9	10	13	118	4	FU1212L0	GN5198V0	GN9589O0
120	106	8.5	9.5	12.5	118	4	FU2148L0	GN4826V0	GN9166O0
125	112	8.5	9.5	12.5	123	4	FU2847L0	GN4827V0	GN9167O0
125	112	9	10	13	123	4	FU1926L0	GN4827V0	GN9167O0
130	115	9	10	13	128	4	FU1278L0	GN4593V0	GN9274O0
140	125	9	10	13	138	4	FU1320L0	GN4481V0	GN9170O0
145	130	9	10	13	143	4	FU2405L0	GN4628V1	GN9742O1
150	135	9	10	13	148	4	FU1356L0	GN5025V0	GN9539O0
150	136	8.5	9.5	12.5	148	4	FU2149L0	GN4830V0	GN9173O0

E DIMENSION OSI

HOW TO DETERMINE B DIMENSION

■ When using backup ring

Please determine B dimension according to the table below. If you require smaller B dimension because of the cylinder configuration, please consult NOK.

Maximum Service Pressure	14MPa	21MPa	35MPa
Material of Backup ring	19YF		
B Dimension	$B \geq \phi D - 1.0$	$B \geq \phi D - 0.5$	$B \geq \phi D - 0.2$

Maximum Service Pressure	35MPa	42MPa
Material of Backup ring	80NP	
B Dimension	$B \geq \phi D - 0.8$	$B \geq \phi D - 0.4$

■ When not using backup ring

To determine B dimension, please refer to the graph in the right for the maximum extrusion gap (one side) considering the eccentricity of operating condition of the piston.

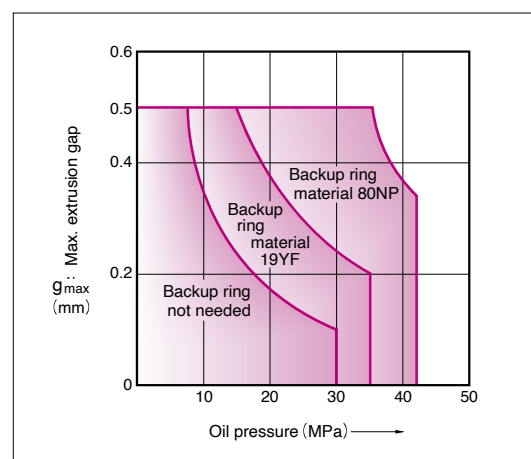

Nominal Size of Packing, and Housing dimensions							Packing Part Number	Combination Backup Ring Part Number	
								BRT2 (Biascut)	BRN2 (Biascut)
D	d	h	H _A	H _B	ϕD_1	C	19YF	80NP	
155	140	9	10	13	153	4	FU1386L0	GN4526V0	GN9410O0
160	145	9	10	13	158	4	FU1404L0	GN4551V0	GN9175O0
170	155	9	10	14	168	4	FU1441L0	GN4834V0	GN9178O0
175	160	9	10	14	173	4	FU1458L0	GN4835V0	GN9180O0
180	165	9	10	14	178	4	FU1481L0	GN4836V0	GN9182O0
190	175	9	10	14	188	4	FU1511L0	GN4839V0	GN9185O0
200	180	12	13	17	198	5	FU1539L0	GN4470V0	GN9187O0
210	190	12	13	17	208	5	FU1572L0	GN4841V0	GN9190O0
220	200	12	13	17	218	5	FU1594L0	GN4385V0	GN9191O0
224	204	12	13	17	222	5	FU1606L0	GN4842V0	GN9193O0
225	205	12	13	17	223	5	FU1618L0	GN5710V0	GN9784O0
230	210	12	13	17	228	5	FU1635L0	GN4627V0	GN9195O0
240	220	12	13	17	238	5	FU1655L0	GN4444V0	GN9196O0
250	230	12	13	17	248	5	FU1675L0	GN4635V0	GN9047O0
260	240	12	13	17	258	5	FU1700L0	GN4845V0	GN9198O0
270	250	12	13	17	268	5	FU1717L0	GN4459V0	GN9199O0
280	255	16	17	21	278	6.5	FU1730L0	GN4846V0	GN9201O0
290	265	16	17	21	288	6.5	FU1745L0	GN4848V0	GN9203O0
300	275	16	17	21	298	6.5	FU1760L0	GN4852V0	GN9207O0

OUIS TYPE

SPECIAL PACKINGS FOR PISTON SEALS IRON RUBBER (PUR)



- Please designate NOK Part number and type & size on your order.

(Example) Order for the packing as a single piece

• Type Dimensions	<u>OUIS</u>	<u>40</u>	<u>30</u>	<u>6</u>	
	└─ Type Sign	└─ Nominal Size of Packing described in order of outer diameter(D), inner diameter(d), and height(h)			
• Part Number	FU0490P0				

※ When placing orders for backup rings used in combination with packing, designate the NOK part number and the model size.

• Type Dimensions	<u>BRT2</u>	<u>30</u>	<u>40</u>	<u>3</u>	
	└─ Type Sign	└─ Nominal Size of Backup ring described in order of inner diameter(d), outer diameter(D), and thickness(t)*			
• Part Number	GN4794V0				*t = H _B - H _A (Housing dimensions)

- Please check the application range on pages 14 and 15 before selecting the type.

Material	Standard : NOK U801 Heat resistant type : NOK U641
-----------------	---

OUIS TYPE SPECIAL PACKINGS FOR PISTON SEALS (INSTALLED WITH INTERNAL GROOVE)

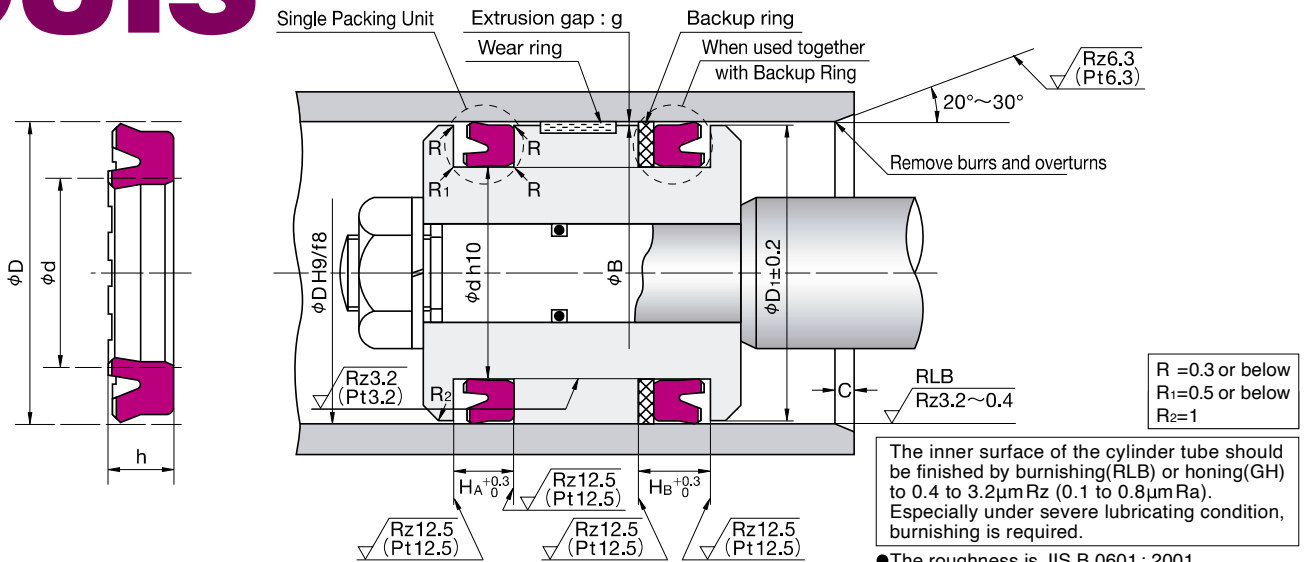

HOW TO DETERMINE B DIMENSION

When using backup ring

Please determine B dimension according to the table below. If you require smaller B dimension because of the cylinder configuration, please consult NOK.

Maximum Service Pressure	14MPa	21MPa	35MPa
Material of Backup ring	19YF		
B Dimension	$B \geq \phi D - 1.0$	$B \geq \phi D - 0.5$	$B \geq \phi D - 0.2$
Maximum Service Pressure	35MPa	42MPa	
Material of Backup ring	80NP		
B Dimension	$B \geq \phi D - 0.8$	$B \geq \phi D - 0.4$	

When not using backup ring

To determine B dimension, please refer to the graph in the right for the maximum extrusion gap (one side) considering the eccentricity of operating condition of the piston.

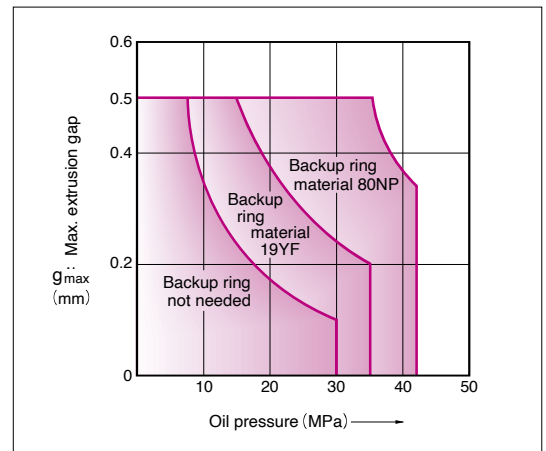

Nominal Size of Packing, and Housing dimensions							Packing Part Number		Combination Backup Ring Part Number	
D	d	h	H _A	H _B	ϕD_1	C	Standard (U801)	Heat resistant (U641)	BRT2 (Biascut) 19YF	BRN2 (Biascut) 80NP
40	30	6	7	10	39	2.5	FU0490P1	FU0490P0	GN4794V0	GN912200
45	35	6	7	10	44	2.5	FU0563P1	FU0563P0	GN4799V0	GN912700
50	40	6	7	10	49	2.5	FU0613P1	FU0613P0	GN4050V0	GN913100
60	50	6	7	10	59	2.5	FU0742P1	FU0742P0	GN4335V0	GN913800
63	53	6	7	10	62	2.5	FU0784P1	FU0784P0	GN4693V0	GN914000
65	55	6	7	10	64	2.5	FU0807P1	FU0807P0	GN4810V0	GN914100
70	60	6	7	10	69	2.5	FU0846P1	FU0846P0	GN4676V0	GN914400
75	65	6	7	10	74	2.5	FU0897P1	FU0897P0	GN4816V0	GN914900
80	70	6	7	10	79	2.5	FU0936P1	FU0936P0	GN4651V0	GN909200
80	71	6	7	10	79	2.5	FU2146P1	FU2146P0	GN4818V0	GN915200
85	75	6	7	10	84	2.5	FU0979P1	FU0979P0	GN4629V0	GN924100
90	80	6	7	10	89	2.5	FU1019P1	FU1019P0	GN4820V0	GN915500
100	85	9	10	13	98	4	FU1078P1	FU1078P0	GN4687V0	GN909100
105	90	9	10	13	103	4	FU1120P1	FU1120P0	GN4698V0	GN915800
110	95	9	10	13	108	4	FU1152P1	FU1152P0	GN4822V0	GN916000
115	100	9	10	13	113	4	FU1193P1	FU1193P0	GN4512V0	GN916300
120	105	9	10	13	118	4	FU1212P1	FU1212P0	GN5198V0	GN958900
125	112	8.5	9.5	12.5	123	4	FU2903P1	FU2903P0	GN4827V0	GN916700
125	112	9	10	13	123	4	FU1926P1	FU1926P0	GN4827V0	GN916700
130	115	9	10	13	128	4	FU1278P1	FU1278P0	GN4593V0	GN927400
140	125	9	10	13	138	4	FU1320P1	FU1320P0	GN4481V0	GN917000
150	135	9	10	13	148	4	FU1356P1	FU1356P0	GN5025V0	GN953900
150	136	8.5	9.5	12.5	148	4	FU2149P1	FU2149P0	GN4830V0	GN917300
160	145	9	10	13	158	4	FU1404P1	FU1404P0	GN4551V0	GN917500
170	155	9	10	14	168	4	FU1441P1	FU1441P0	GN4834V0	GN917800
175	160	9	10	14	173	4	FU1458P1	FU1458P0	GN4835V0	GN918000
180	165	9	10	14	178	4	FU1481P1	FU1481P0	GN4836V0	GN918200
190	175	9	10	14	188	4	FU1511P1	FU1511P0	GN4839V0	GN918500
200	180	12	13	17	198	5	FU1539P1	FU1539P0	GN4470V0	GN918700
224	204	12	13	17	222	5	FU1606P1	FU1606P0	GN4842V0	GN919300
250	230	12	13	17	248	5	FU1675P1	FU1675P0	GN4635V0	GN904700

OUHR TYPE

**SPECIAL PACKINGS
FOR PISTON SEALS
NITRILE RUBBER (NBR)**



● Please designate NOK Part number and type & size on your order.

(Example) Order for the packing as a single piece

• Type Dimensions	<u>OUHR</u>	<u>32</u>	<u>24</u>	<u>5</u>	
	└─ Type Sign	└─ Nominal Size of Packing described in order of outer diameter(D), inner diameter(d), and height(h)			
• Part Number	CU2683Q2				

※ When placing orders for backup rings used in combination with packing, designate the NOK part number and the model size.

• Type Dimensions	<u>BRT2</u>	<u>24</u>	<u>32</u>	<u>2</u>	
	└─ Type Sign	└─ Nominal Size of Backup ring described in order of inner diameter(d), outer diameter(D), and thickness(t)*			
• Part Number	GN5727V0				*t = H _B - H _A (Housing dimensions)

● Please check the application range on pages 14 and 15 before selecting the type.

Material	Standard : NOK A505 Cold resistant type : NOK A567
-----------------	---

OUHR TYPE SPECIAL PACKINGS FOR PISTON SEALS (INSTALLED WITH INTERNAL GROOVE)

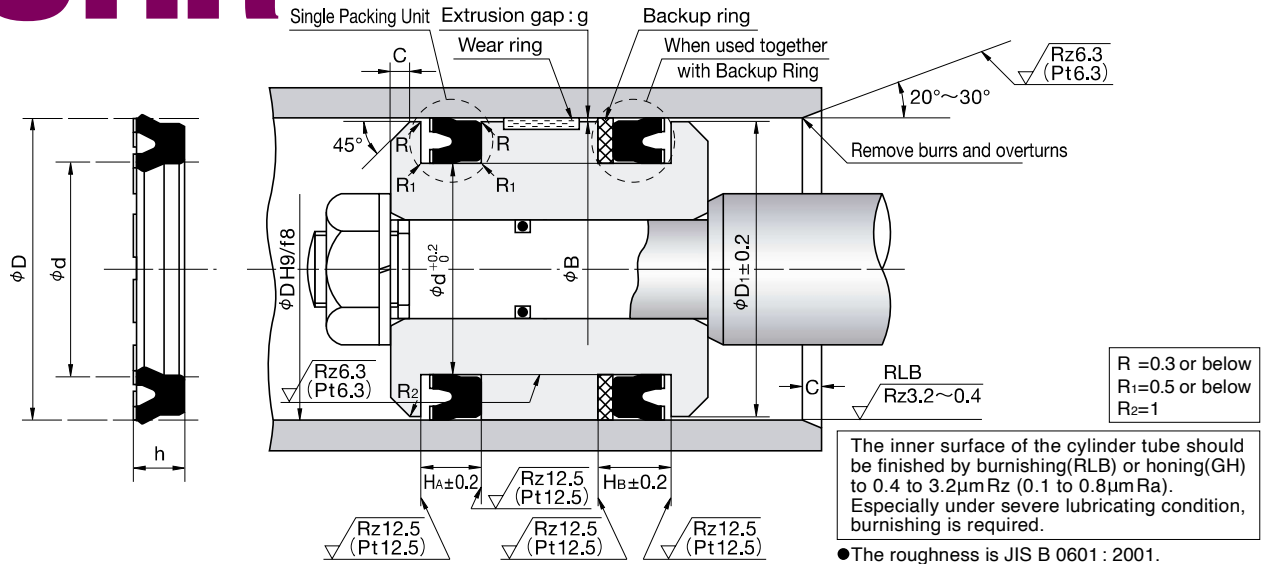

HOW TO DETERMINE B DIMENSION

■ When using backup ring

Please determine B dimension according to the table below. If you require smaller B dimension because of the cylinder configuration, please consult NOK.

Maximum Service Pressure	14MPa	21MPa
Material of Backup ring	19YF	
B Dimension	$B \geq \phi D - 1.0$	$B \geq \phi D - 0.5$

■ When not using backup ring

To determine B dimension, please refer to the graph in the right for the maximum extrusion gap (one side) considering the eccentricity of operating condition of the piston.

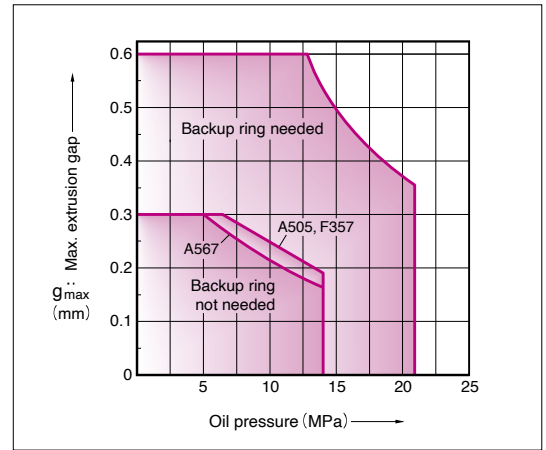

Nominal Size of Packing, and Housing dimensions							Packing Part Number		Combination Backup Ring Part Number
D	d	h	H _A	H _B	φD ₁	C	Standard (A505)	Cold resistant (A567)	BRT2 (Biascut) 19YF
32	24	5	5.7	7.7	31	3.5	CU2683Q2	CU2683Q3	GN5727V0
40	30	6	7	10	39	3.5	CU2684Q3	CU2684Q5	GN4794V0
50	40	6	7	10	49	3.5	CU2604Q3	CU2604Q4	GN4050V0
55	45	6	7	10	54	3.5	CU2697Q1		GN4804V0
60	50	6	7	10	59	3.5	CU2696Q2	CU2696Q3	GN4335V0
63	53	6	7	10	62	3.5	CU2685Q0	CU2685Q4	GN4693V0
65	55	6	7	10	64	3.5	CU2930Q2	CU2930Q3	GN4810V0
70	60	6	7	10	69	3.5		CU2634Q2	GN4676V0
75	62	7.5	8.5	11.5	74	4.5	CU2943Q2	CU2943Q3	GN5712V0
80	65	9	10	13	79	4.5	CU2666Q2	CU2666Q3	GN4549V0
80	71	6	7	10	79	4.5	CU3238Q1		GN4818V0
85	70	9	10	13	84	4.5	CU0977Q2	CU0977Q3	GN4876V0
95	80	9	10	13	94	4.5	CU2605Q2	CU2605Q4	GN5023V0
100	85	9	10	13	98	4.5	CU2669Q2	CU2669Q3	GN4687V0
110	95	9	10	13	108	4.5	CU2607Q2	CU2607Q3	GN4822V0
115	100	9	10	13	113	4.5		CU3241Q2	GN4512V0
125	110	9	10	13	123	4.5		CU2670Q2	GN4480V0
125	112	8.5	9.5	12.5	123	4.5	CU3492Q0		GN4827V0
140	125	9	10	13	138	4.5	CU2647Q3	CU2647Q2	GN4481V0
150	136	8.5	9.5	12.5	148	4.5	CU3244Q1		GN4830V0
160	145	9	10	13	158	4.5	CU2687Q1		GN4551V0
180	165	9	10	14	178	4.5	CU2688Q1		GN4836V0
200	180	12	13	17	198	5.5	CU1539Q1	CU1539Q2	GN4470V0
224	204	12	13	17	222	5.5	CU3491Q0		GN4842V0
250	230	12	13	17	248	5.5	CU2691Q2	CU2691Q3	GN4635V0

OKH_{TYPE}

SPECIAL PACKINGS FOR PISTON SEALS
NITRILE RUBBER (NBR)

OKH_{TYPE}+BRL_{TYPE}

COMBINED WEAR RING AND BACKUP RING
POLYAMIDE RESIN (PA)



E
DIMENSION
OKH
BRL
L+

- Please designate NOK Part number and type & size on your order.

(Example) Order for the packing as a single piece

• Type Dimensions	OKH	40	30	6.5	
	└─ Type Sign		└─ Nominal Size of Packing described in order of outer diameter(D), inner diameter(d), and height(h)		
• Part Number	CQ0371C0				

※ When placing orders for Combined wear ring and backup ring, designate the NOK part number and the model size.

• Type Dimensions	BRL	30	40	5.5	
	└─ Type Sign		└─ Nominal Size of Backup ring described in order of inner diameter(d), outer diameter(D), and height(h)		
• Part Number	GN9965V0				

- Please check the application range on pages 14 and 15 before selecting the type.

Material	Standard : NOK A566 + NOK 63NP or NOK 19YF Cold resistant type : NOK A567
-----------------	--

OKH TYPE + BRL TYPE SPECIAL PACKINGS FOR PISTON SEALS

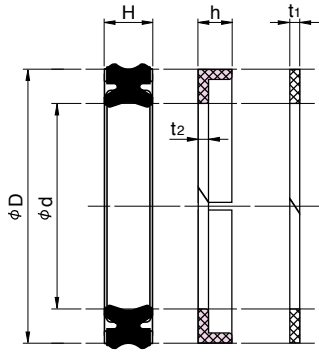

BRL BRT2

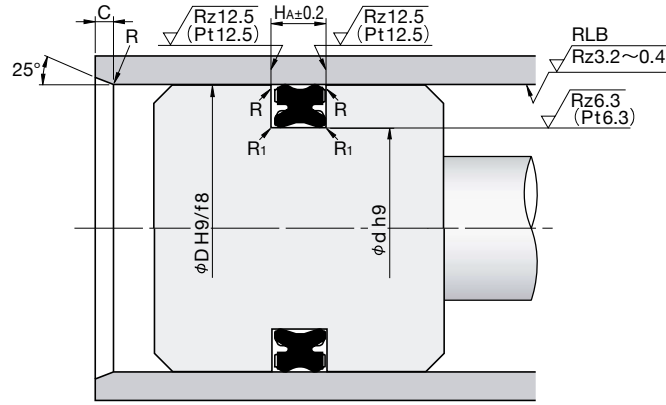

● When used together with BRT2

● When used together with BRL

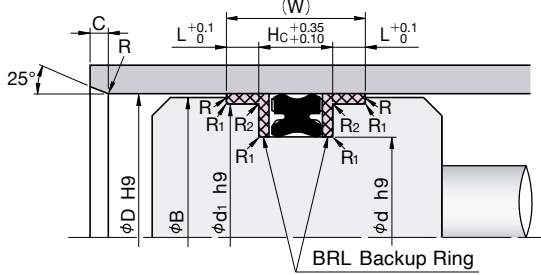

BRL Backup Ring

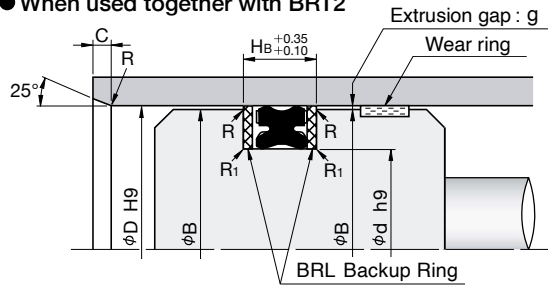

Extrusion gap : g

Wear ring

BRL Backup Ring

R = 0.3 or below
R₁ = 0.4 or below
R₂ = 0.2

Surface roughness of each part

● with BRL

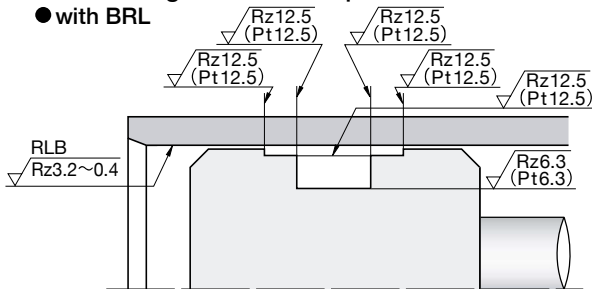

● only OKH · with BRT2

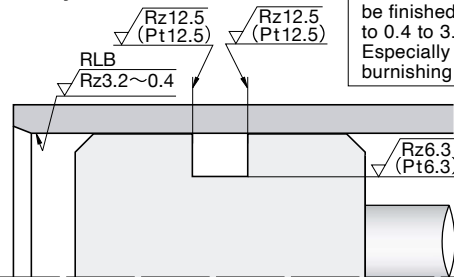

The inner surface of the cylinder tube should be finished by burnishing (RLB) or honing (GH) to 0.4 to 3.2μm Rz (0.1 to 0.8μm Ra). Especially under severe lubricating condition, burnishing is required.

● The roughness is JIS B 0601 : 2001.
When regulation length cannot be kept, apply Pt.

E
DIMENSION
OKH
R
+ L

HOW TO DETERMINE B DIMENSION

■ When using backup ring

Please determine B dimension according to the table below. If you require smaller B dimension because of the cylinder configuration, please consult NOK.

Maximum Service Pressure	14MPa	21MPa
Material of Backup ring	63NP, 19YF	
B Dimension	$B \geq \phi D - 1.0$	$B \geq \phi D - 0.5$

■ When not using backup ring

To determine B dimension, please refer to the graph in the right for the maximum extrusion gap (one side) considering the eccentricity of operating condition of the piston.

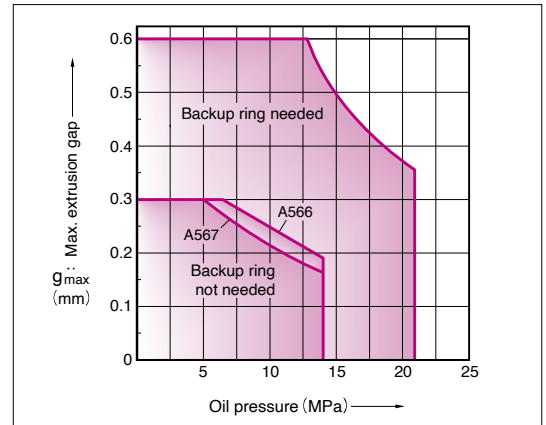

Nominal Number	Nominal Size of Packing, and Housing dimensions												Packing Part Number		Combination Backup Ring Part Number		
	D	d	H	t ₁	t ₂	h	φd ₁	H _A	H _B	H _C	L	(W)	C	Standard (A566)	Heat resistant (A567)	BRL also be used as Wear Ring	BRT2 (Biascut)
OKH40	40	30	6.5	2	1.5	5.5	37	7	11	10	4	18	2.5	CQ0371C0	CQ0371C1	GN9965V0	GN4662V0
45	45	35	6.5	2	1.5	5.5	42	7	11	10	4	18	2.5	CQ0372C0	CQ0372C1	GN9966V0	GN5765V0
50	50	40	6.5	2	1.5	5.5	47	7	11	10	4	18	2.5	CQ0311C1	CQ0311C2	GN9967V0	GN4672V0
55	55	45	6.5	2	1.5	5.5	52	7	11	10	4	18	2.5	CQ0373C0	CQ0373C1	GN9968V0	GN5480V0
60	60	50	6.5	2	1.5	5.5	57	7	11	10	4	18	2.5	CQ0316C0	CQ0316C1	GN9696V1	GN4976V0
63	63	53	6.5	2	1.5	5.5	60	7	11	10	4	18	2.5	CQ0374C0	CQ0374C1	GN9969V0	GN5511V0
65	65	55	6.5	2.5	2	7	61	7	12	11	5	21	2.5	CQ0329C0	CQ0329C1	GN9730V1	GN5766V0
70	70	60	6.5	2.5	2	7	66	7	12	11	5	21	2.5	CQ0313C1	CQ0313C2	GN9695V1	GN5525V0
75	75	65	6.5	2.5	2	7	71	7	12	11	5	21	2.5	CQ0375C0	CQ0375C1	GN9970V0	GN5767V0
80	80	67	8	2.5	2	7	76	8.5	13.5	12.5	5	22.5	3	CQ0330C0	CQ0330C1	GN9731V1	GN5768V0
85	85	72	8	2.5	2	7	81	8.5	13.5	12.5	5	22.5	3	CQ0376C0	CQ0376C1	GN9971V0	GN5769V0
90	90	77	8	2.5	2	7	86	8.5	13.5	12.5	5	22.5	3	CQ0377C0	CQ0377C1	GN9972V0	GN5770V0
100	100	85	9	3	2	7	96	10	16	14	5	24	4	CQ0378C0	CQ0378C1	GN9973V0	GN4687V0

SPGO TYPE SPECIAL PACKINGS FOR PISTON SEALS

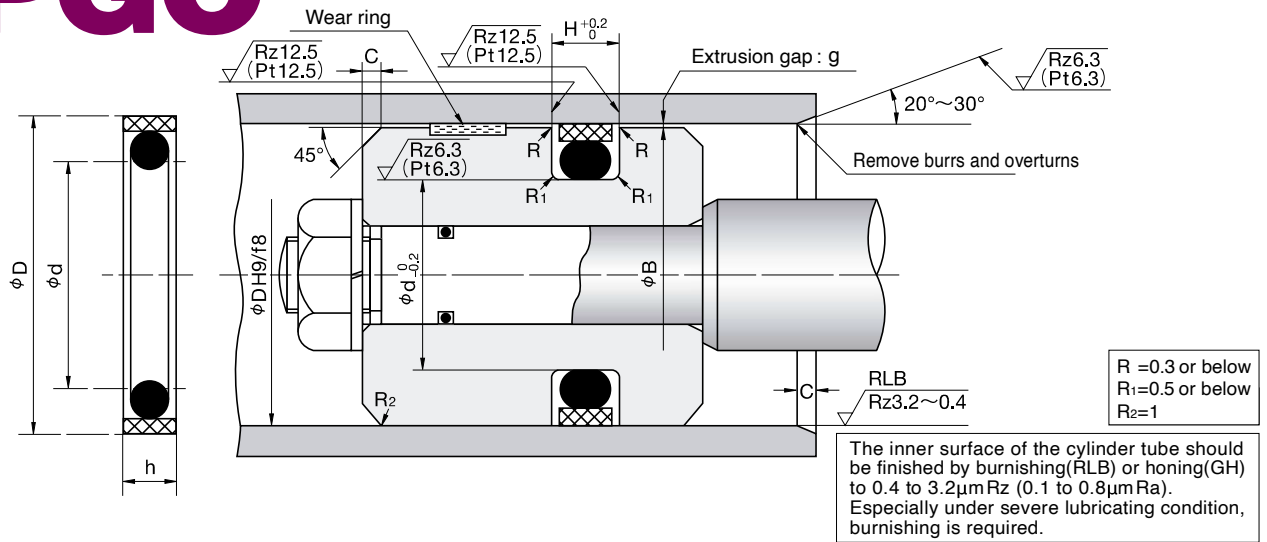

● The roughness is JIS B 0601 : 2001.
When regulation length cannot be kept, apply Pt.

Nominal Number	Nominal Size of Packing, and Housing dimensions					NOK Part Number
	d	D	h	H	C	
SPGO 20	14	20	3	3.2	2	GS1800V0
25	19	25	3	3.2	2	GS1801V0
30	21.5	30	3.8	4	3.5	GS1802V0
31.5	23	31.5	3.8	4	3.5	GS1803V0
32	23.5	32	3.8	4	3.5	GS1804V0
35	26.5	35	3.8	4	3.5	GS1805V0
35.5	27	35.5	3.8	4	3.5	GS1806V0
40	31.5	40	3.8	4	3.5	GS1807V0
45	36.5	45	3.8	4	3.5	GS1808V0
50	41.5	50	3.8	4	4	GS1809V0
53	44.5	53	3.8	4	4	GS1810V0
55	46.5	55	3.8	4	4	GS1811V0
56	47.5	56	3.8	4	4	GS1812V0
60	51.5	60	3.8	4	4	GS1813V0
63	49	63	6.3	6.5	4	GS1814V0
65	51	65	6.3	6.5	4	GS1815V0
70	56	70	6.3	6.5	5	GS1816V0
71	57	71	6.3	6.5	5	GS1817V0
75	61	75	6.3	6.5	5	GS1818V0
80	66	80	6.3	6.5	5	GS1819V0
85	71	85	6.3	6.5	5	GS1820V0
90	76	90	6.3	6.5	5	GS1821V0
95	81	95	6.3	6.5	5	GS1822V0
100	86	100	6.3	6.5	5	GS1823V0
105	91	105	6.3	6.5	5	GS1824V0
110	96	110	6.3	6.5	5	GS1825V0
112	98	112	6.3	6.5	6.5	GS1826V0
115	101	115	6.3	6.5	6.5	GS1827V0
120	106	120	6.3	6.5	6.5	GS1828V0

E DIMENSION SPGO

HOW TO DETERMINE B DIMENSION

To determine B dimension, please refer to the graph in the right for the maximum extrusion gap (one side) considering the eccentricity of operating condition of the piston.

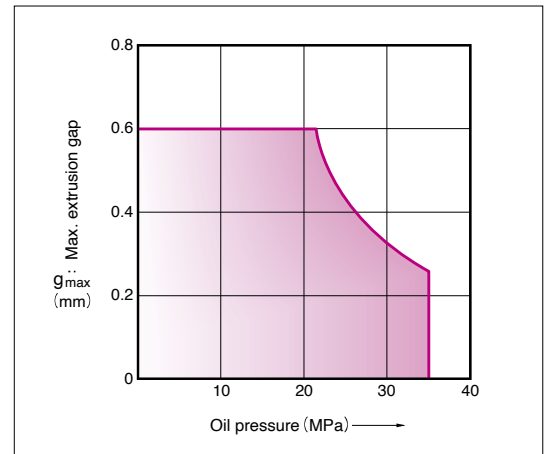

Nominal Number	Nominal Size of Packing, and Housing dimensions					NOK Part Number
	d	D	h	H	C	
SPGO 125	111	125	6.3	6.5	6.5	GS1829V0
130	116	130	6.3	6.5	6.5	GS1830V0
135	121	135	6.3	6.5	6.5	GS1831V0
140	126	140	6.3	6.5	6.5	GS1832V0
150	136	150	6.3	6.5	6.5	GS1833V0
160	146	160	6.3	6.5	6.5	GS1834V0
170	150	170	9.8	10	6.5	GS1835V0
180	160	180	9.8	10	6.5	GS1836V0
190	170	190	9.8	10	6.5	GS1837V0
200	180	200	9.8	10	6.5	GS1838V0
210	190	210	9.8	10	6.5	GS1839V0
220	200	220	9.8	10	6.5	GS1840V0
224	204	224	9.8	10	6.5	GS1841V0
230	210	230	9.8	10	6.5	GS1842V0
240	220	240	9.8	10	6.5	GS1843V0
250	230	250	9.8	10	6.5	GS1844V0
260	240	260	9.8	10	7.5	GS1845V0
270	250	270	9.8	10	7.5	GS1846V0
280	260	280	9.8	10	7.5	GS1847V0
290	270	290	9.8	10	7.5	GS1848V0
300	280	300	9.8	10	7.5	GS1849V0
310	290	310	9.8	10	7.5	GS1850V0
320	300	320	9.8	10	7.5	GS1851V0
340	320	340	9.8	10	7.5	GS1852V0
350	330	350	9.8	10	7.5	GS1853V0
360	340	360	9.8	10	7.5	GS1854V0
375	355	375	9.8	10	7.5	GS1855V0
380	360	380	9.8	10	7.5	GS1856V0
400	380	400	9.8	10	7.5	GS1857V0

SPG TYPE SPECIAL PACKINGS FOR PISTON SEALS

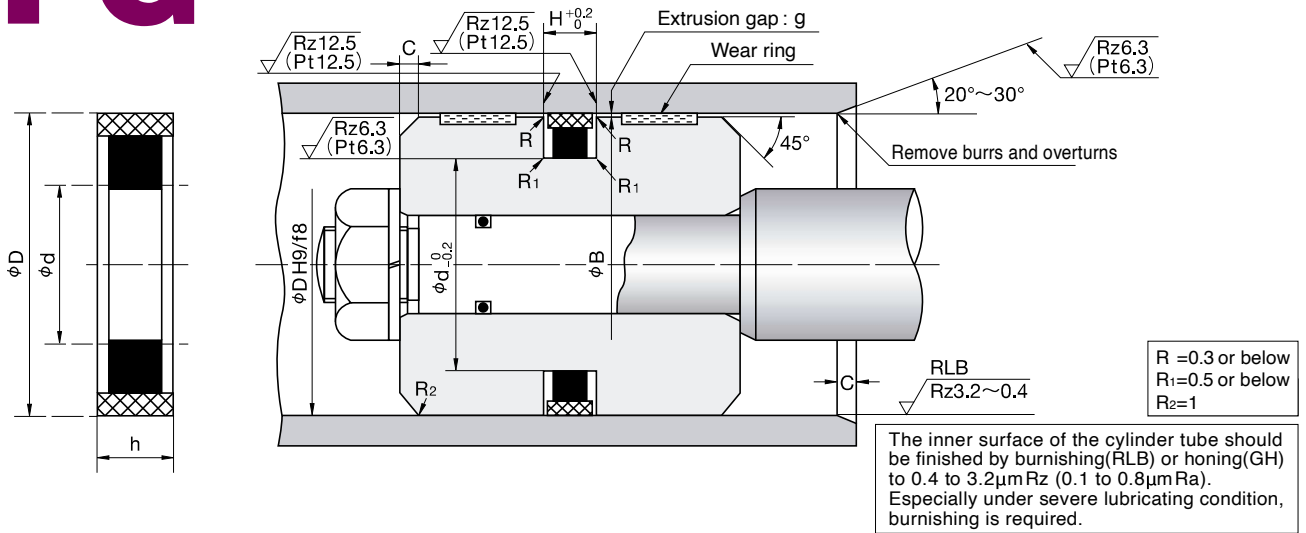

● The roughness is JIS B 0601 : 2001.
When regulation length cannot be kept, apply Pt.

Nominal Number	Nominal Size of Packing, and Housing dimensions					NOK Part Number
	d	D	h	H	C	
SPG 30	20.5	30	4.3	4.5	2	GS0327V0
31.5	22	31.5	4.3	4.5	3.5	GS0328V0
32	22.5	32	4.3	4.5	3.5	GS0329V0
35	25.5	35	4.3	4.5	3.5	GS0330V0
35.5	26	35.5	4.3	4.5	3.5	GS0331V0
40	30	40	4.3	4.5	3.5	GS0332V0
45	35	45	4.3	4.5	3.5	GS0333V0
50	40	50	4.3	4.5	4	GS0334V0
55	45	55	4.3	4.5	4	GS0335V0
56	46	56	4.3	4.5	4	GS0336V0
60	50	60	4.3	4.5	4	GS0337V0
63	48	63	7.3	7.5	4	GS0338V0
65	50	65	7.3	7.5	4	GS0339V0
69	54	69	7.3	7.5	4	GS0340V0
70	55	70	7.3	7.5	5	GS0341V0
71	56	71	7.3	7.5	5	GS0342V0
75	60	75	7.3	7.5	5	GS0343V0
80	65	80	7.3	7.5	5	GS0344V0
85	70	85	7.3	7.5	5	GS0345V0
90	75	90	7.3	7.5	5	GS0310V0
95	80	95	7.3	7.5	5	GS0346V0
100	85	100	7.3	7.5	5	GS0347V0
105	90	105	7.3	7.5	5	GS3509V0
108	92	108	7.3	7.5	5	GS0348V0
110	94	110	7.3	7.5	5	GS0311V0
112	96	112	7.3	7.5	6.5	GS0349V0
120	104	120	7.3	7.5	6.5	GS0350V0

E DIMENSION SPG

HOW TO DETERMINE B DIMENSION

To determine B dimension, please refer to the graph in the right for the maximum extrusion gap (one side) considering the eccentricity of operating condition of the piston.

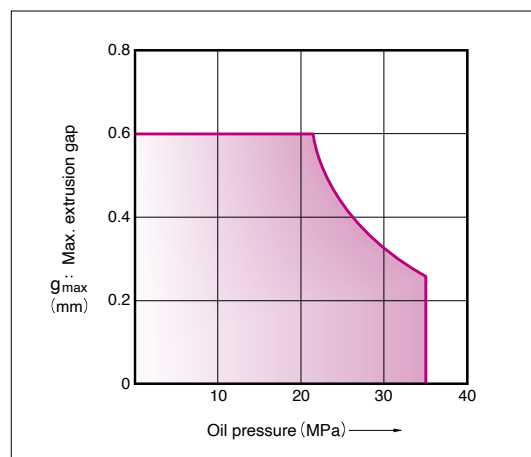

Nominal Number	Nominal Size of Packing, and Housing dimensions					NOK Part Number
	d	D	h	H	C	
SPG 125	109	125	7.3	7.5	6.5	GS0351V0
130	114	130	7.3	7.5	6.5	GS0352V0
135	119	135	7.3	7.5	6.5	GS0806V1
140	124	140	7.3	7.5	6.5	GS0353V0
145	129	145	7.3	7.5	6.5	GS0885V0
150	134	150	7.3	7.5	6.5	GS0354V0
155	139	155	7.3	7.5	6.5	GS3133V1
160	144	160	7.3	7.5	6.5	GS0355V0
170	148	170	10.8	11	6.5	GS0356V0
180	158	180	10.8	11	6.5	GS0357V0
190	168	190	10.8	11	6.5	GS0358V0
200	178	200	10.8	11	6.5	GS0359V0
204	182	204	10.8	11	6.5	GS0360V0
210	188	210	10.8	11	6.5	GS0361V0
215	193	215	10.8	11	6.5	GS0548V0
220	198	220	10.8	11	6.5	GS0842V0
224	202	224	10.8	11	6.5	GS0362V0
225	203	225	10.8	11	6.5	GS0363V0
230	208	230	10.8	11	6.5	GS0364V0
240	218	240	10.8	11	6.5	GS0365V0
250	228	250	10.8	11	6.5	GS0366V0
260	236	260	11.7	12	7.5	GS0700V0
270	246	270	11.7	12	7.5	GS0701V0
280	256	280	11.7	12	7.5	GS0702V0
290	266	290	11.7	12	7.5	GS0703V0
300	276	300	11.7	12	7.5	GS0704V0
310	286	310	11.7	12	7.5	GS0705V0
320	296	320	11.7	12	7.5	GS0706V0

SPG TYPE SPECIAL PACKINGS FOR PISTON SEALS (LARGE DIMENSION)

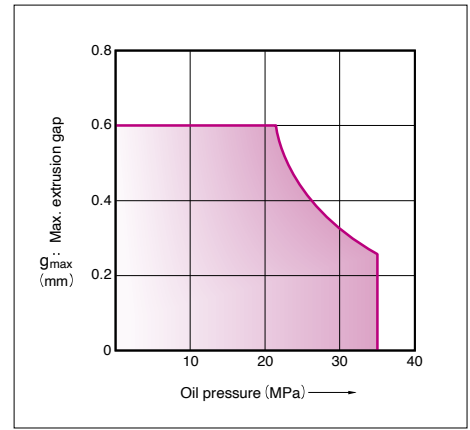
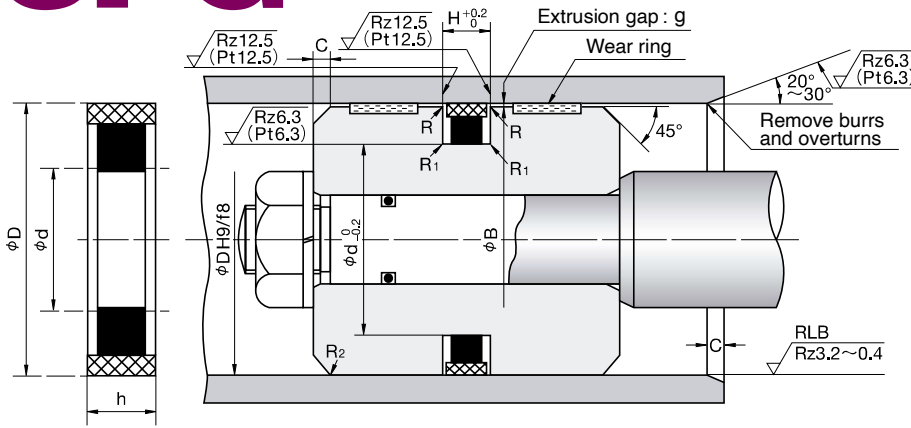

The inner surface of the cylinder tube should be finished by burnishing (RLB) or honing (GH) to 0.4 to $3.2\mu\text{m Rz}$ (0.1 to $0.8\mu\text{m Ra}$). Especially under severe lubricating condition, burnishing is required.

$R = 0.3$ or below
 $R_1 = 0.5$ or below
 $R_2 = 1$

● The roughness is JIS B 0601 : 2001. When regulation length cannot be kept, apply Pt.

HOW TO DETERMINE B DIMENSION

To determine B dimension, please refer to the graph in the right for the maximum extrusion gap (one side) considering the eccentricity of operating condition of the piston.

Nominal Number	Nominal Size of Packing, and Housing dimensions					NOK Part Number
	d	D	h	H	C	
SPG 330	308	330	9.75	10	10	GS0408V0
360	336	360	11.7	12	10	GS0917V0
400	376	400	11.7	12	10	GS3361V0
485	455	485	14.8	15	10	GS0504V1
500	470	500	14.8	15	10	GS0261V2
550	515	550	17.2	17.5	10	GS0379V2
600	570	600	14.8	15	10	GS0324V2
650	620	650	14.8	15	15	GS0527V0
720	690	720	14.8	15	15	GS0492V0
800	785	800	12.7	13	15	GS0520V0
900	870	900	24.5	25	15	GS0407V2
930	890	930	19	20	15	GS0466V1
935	920	935	12.7	13	15	GS0521V0
950	925	950	17.7	18	15	GS0285V2
1000	960	1000	19.7	20	20	GS0512V0
1060	1020	1060	19.7	20	20	GS0587V0
1120	1080	1120	19.7	20	20	GS0584V0
1150	1110	1150	19.7	20	20	GS3007V0
1180	1130	1180	19.7	20	20	GS0599V1
1210	1170	1210	19	20	20	GS0465V0
1250	1210	1250	19.7	20	20	GS0281V1
1260	1220	1260	19.7	20	20	GS0851V0
1400	1350	1400	19.7	20	20	GS0402V0
1500	1460	1500	19.7	20	20	GS0852V0
1650	1600	1650	24	25	20	GS0579V0

SPGM_{TYPE}

SPECIAL PACKINGS
FOR PISTON SEALS

RAREFLON (PTFE) +
NITRILE RUBBER (NBR)



E
DIMENSION
SPGM

- Please designate NOK Part number and type & size on your order.

(Example) Order for the packing as a single piece

• Type Dimensions	SPGM	24.5	32	3
	└─ Type Sign	└─ Nominal Size of Packing described in order of inner diameter(d), outer diameter(D), and height(h)		
• Part Number	GS4283V0			

- Please check the application range on pages 14 and 15 before selecting the type.

Material	NOK 55YF + NOK A305
-----------------	---------------------

SPGM^{TYPE} SPECIAL PACKINGS FOR PISTON SEALS

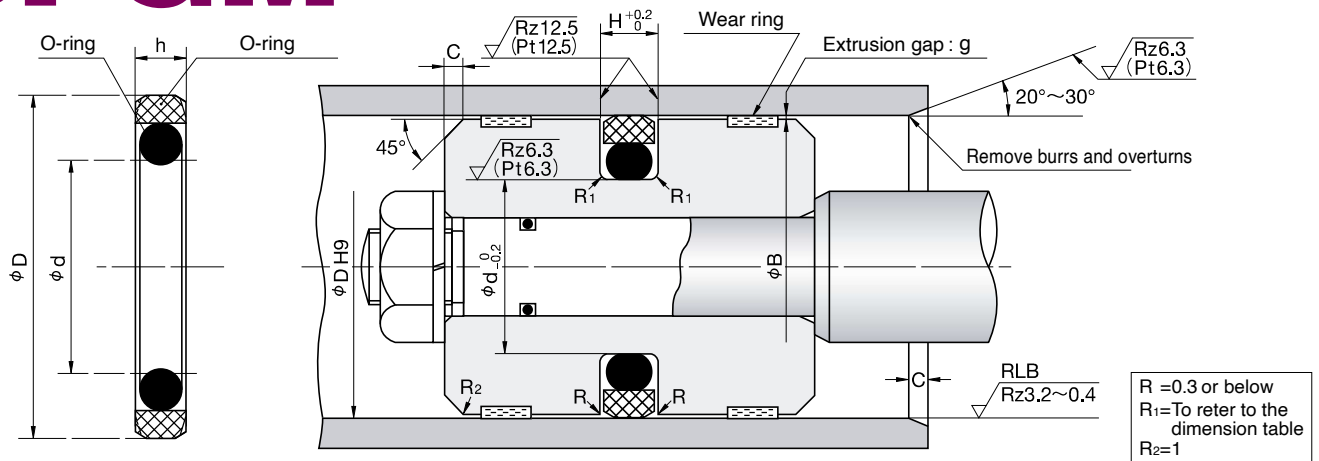

The inner surface of the cylinder tube should be finished by burnishing (RLB) or honing (GH) to 0.4 to 3.2 μm Rz (0.1 to 0.8 μm Ra). Especially under severe lubricating condition, burnishing is required.

- The roughness is JIS B 0601 : 2001.
When regulation length cannot be kept, apply Pt.

HOW TO DETERMINE B DIMENSION

To determine B dimension, please refer to the graph in the right for the maximum extrusion gap (one side) considering the eccentricity of operating condition of the piston.

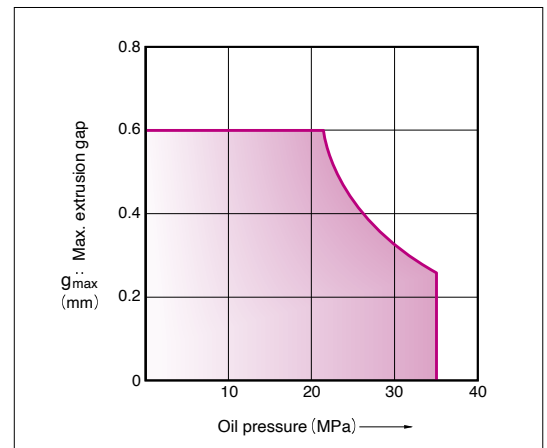

E DIMENSION
SPGM

Nominal Number	Nominal Size of Packing, and Housing dimensions						NOK Part Number
	d	D	h	H	Bottom of groove R_1	C	
SPGM 32 S	24.5	32	3	3.2	0.6 or below	4	GS4283V0
40 S	29	40	4	4.2	1.0 or below	4	GS4284V0
50 S	39	50	4	4.2	1.0 or below	4	GS4285V0
63 S	52	63	4	4.2	1.0 or below	4	GS4286V0
80 S	64.5	80	6.1	6.3	1.3 or below	5	GS4288V0
100 S	84.5	100	6.1	6.3	1.3 or below	5	GS3882V2
125 S	109.5	125	6.1	6.3	1.3 or below	5	GS4289V0
140 S	119	140	7.7	8.1	1.8 or below	6.5	GS3703V1
150 S	129	150	7.7	8.1	1.8 or below	6.5	GS3683V2
160 S	139	160	7.7	8.1	1.8 or below	6.5	GS3704V3
180 S	159	180	7.7	8.1	1.8 or below	6.5	GS4088V1
200 S	179	200	7.7	8.1	1.8 or below	6.5	GS3764V1
250 S	229	250	7.7	8.1	1.8 or below	6.5	GS4291V0

SPGN_{TYPE}

**SPECIAL PACKINGS
FOR PISTON SEALS**

**POLYAMIDE RESIN +
NITRILE RUBBER (NBR)**



E
DIMENSION
SPGN

● Please designate NOK Part number and type & size on your order.

(Example) Order for the packing as a single piece

• Type Dimensions	SPGN	54	75	7.8	
	└─ Type Sign	└─ Nominal Size of Packing described in order of inner diameter(d), outer diameter(D), and height(h)			
• Part Number	GS4243V0				

● Please check the application range on pages 14 and 15 before selecting the type.

Material	NOK 21NB + NOK A626
-----------------	---------------------

SPGN^{TYPE} SPECIAL PACKINGS FOR PISTON SEALS

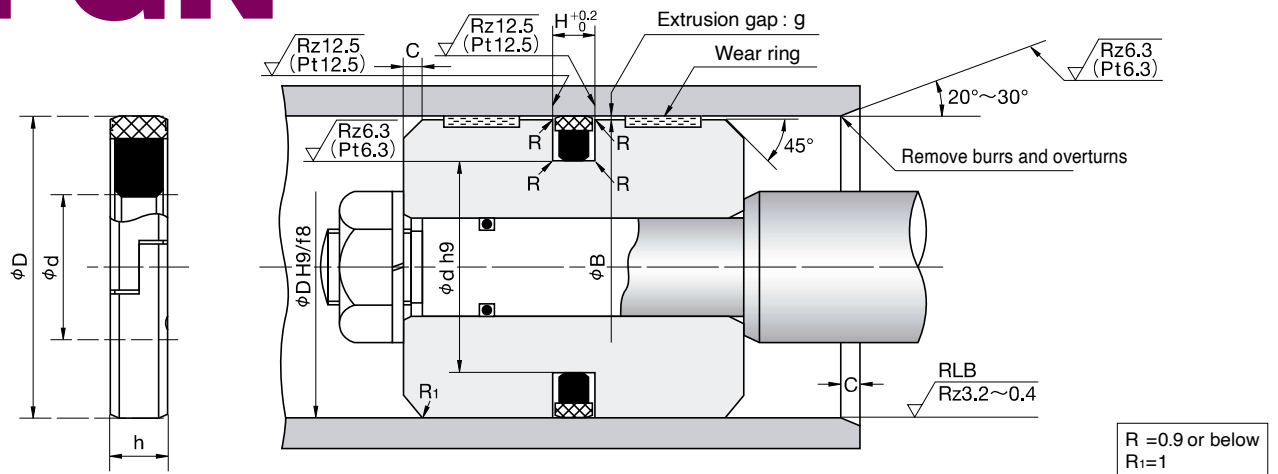

The inner surface of the cylinder tube should be finished by burnishing(RLB) or honing(GH) to 0.4 to 3.2μm Rz (0.1 to 0.8μm Ra). Especially under severe lubricating condition, burnishing is required.

- The roughness is JIS B 0601 : 2001. When regulation length cannot be kept, apply Pt.

HOW TO DETERMINE B DIMENSION

To determine B dimension, please refer to the graph in the right for the maximum extrusion gap (one side) considering the eccentricity of operating condition of the piston.

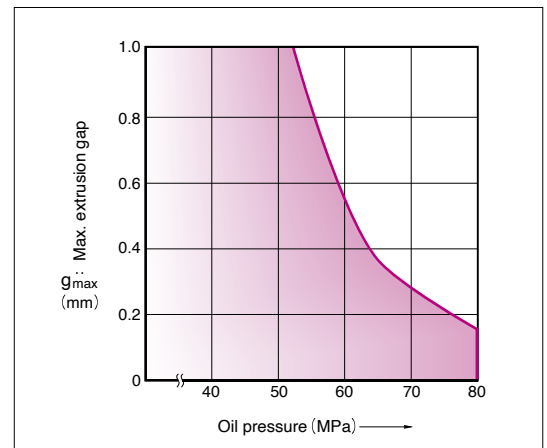

Nominal Number	Nominal Size of Packing, and Housing dimensions					NOK Part Number
	d	D	h	H	C	
SPGN 75	54	75	7.8	8.0	5.0	GS4243V0
80	59	80	7.8	8.0	5.0	GS4244V0
85	64	85	7.8	8.0	5.0	GS4245V0
90	69	90	7.8	8.0	5.0	GS4246V0
95	74	95	7.8	8.0	5.0	GS4247V0
100	79	100	7.8	8.0	5.0	GS4248V0
105	84	105	7.8	8.0	5.0	GS4249V0
110	89	110	7.8	8.0	5.0	GS4250V0
115	94	115	7.8	8.0	6.5	GS4251V0
120	99	120	7.8	8.0	6.5	GS4252V0
125	104	125	7.8	8.0	6.5	GS4253V0
130	109	130	7.8	8.0	6.5	GS4254V0
135	114	135	7.8	8.0	6.5	GS4255V0
140	119	140	7.8	8.0	6.5	GS4256V0
145	124	145	7.8	8.0	6.5	GS4257V0
150	129	150	7.8	8.0	6.5	GS4258V0
160	139	160	7.8	8.0	6.5	GS4259V0
170	149	170	7.8	8.0	6.5	GS4261V0
180	159	180	7.8	8.0	6.5	GS4263V0
190	169	190	7.8	8.0	6.5	GS4264V0
200	179	200	7.8	8.0	6.5	GS4266V0

E DIMENSION
SPGN

SPGW TYPE

SPECIAL PACKINGS FOR PISTON SEALS

RAREFLON (PTFE) +
POLYAMIDE RESIN +
NITRILE RUBBER (NBR)

RAREFLON (PTFE) +
POLYAMIDE RESIN +
HYDROGENATED NITRILE RUBBER (H-NBR)



● Please designate NOK Part number and type & size on your order.

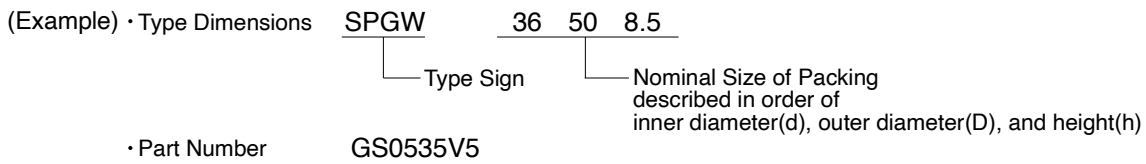

● Please check the application range on pages 14 and 15 before selecting the type.

Material	NOK 19YF + NOK A980 + NOK 80NP NOK G928
	NOK 19YF + NOK A980 + NOK 12NM NOK G928

SPGW TYPE SPECIAL PACKINGS FOR PISTON SEALS

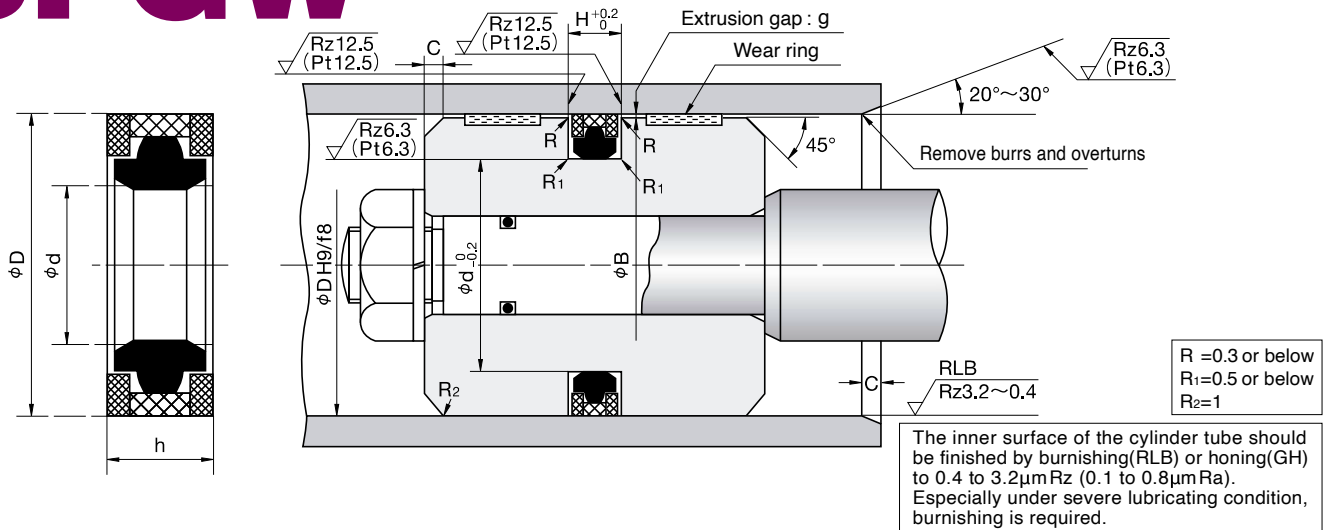

Nominal Number	Nominal Size of Packing, and Housing dimensions					NOK Part Number	
	d	D	h	H	C	Standard Backup Ring (A980)	Heat resistant Backup Ring (G928)
SPGW 50	36	50	8.5	9	4	GS0535V5	
60	46	60	8.5	9	4	GS0528V5	GS00528-V4A
65	50	65	10.5	11	5	GS3013V5	GS3013V6
70	55	70	10.5	11	5	GS0607V5	GS0607V7
75	60	75	10.5	11	5	GS0995V5	GS0995V6
80	65	80	10.5	11	5	GS0608V5	GS0608V8
85	70	85	10.5	11	5	GS0813V5	GS0813V6
90	75	90	10.5	11	5	GS0609V5	GS0609V7
95	80	95	10.5	11	5	GS0481V5	GS0481V6
100	85	100	12	12.5	5	GS0610V6	GS0610V8
105	90	105	12	12.5	5	GS0973V5	GS0973V7
110	95	110	12	12.5	5	GS0611V5	GS0611V6
115	100	115	12	12.5	6.5	GS0626V5	GS0626V6
120	105	120	12	12.5	6.5	GS0612V7	GS0612V8
125	102	125	15.5	16	6.5	GS0583V5	GS0583V6
130	107	130	15.5	16	6.5	GS0613V5	GS0613V7
135	112	135	15.5	16	6.5	GS0908V5	GS0908V6
140	117	140	15.5	16	6.5	GS0432V5	GS0432V7
145	122	145	15.5	16	6.5	GS0907V1	GS0907V2

E DIMENSION SPGW

HOW TO DETERMINE B DIMENSION

To determine B dimension, please refer to the graph in the right for the maximum extrusion gap (one side) considering the eccentricity of operating condition of the piston.

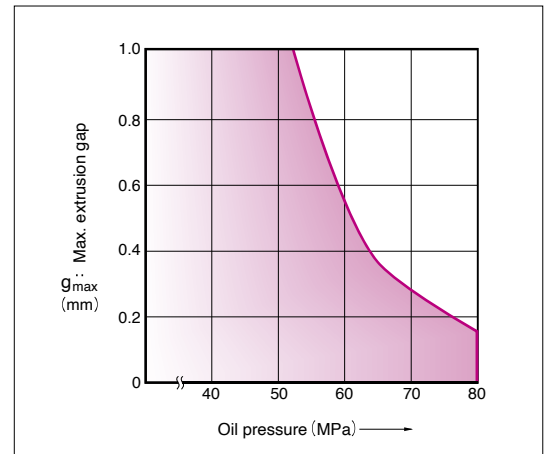

Nominal Number	Nominal Size of Packing, and Housing dimensions					NOK Part Number	
	d	D	h	H	C	Standard Backup Ring (A980)	Heat resistant Backup Ring (G928)
SPGW 150	127	150	15.5	16	6.5	GS0614V5	GS0614V7
160	137	160	15.5	16	6.5	GS0615V5	GS0615V8
170	147	170	15.5	16	6.5	GS0688V5	GS0688V6
180	157	180	15.5	16	6.5	GS0616V5	GS0616V7
185	162	185	15.5	16	6.5	GS0653V5	GS0653V6
190	167	190	15.5	16	6.5	GS0644V5	GS0644V6
200	177	200	15.5	16	6.5	GS0617V5	GS0617V7
210	187	210	15.5	16	6.5	GS0654V2	GS0654V4
220	197	220	15.5	16	6.5	GS0655V2	
225	202	225	15.5	16	6.5	GS0618V2	GS0618V8
230	207	230	15.5	16	6.5	GS0664V2	GS00664-V4A
240	217	240	15.5	16	6.5	GS0656V2	GS00656-V4A
250	222	250	17	17.5	6.5	GS0451V4	
260	232	260	17	17.5	7.5	GS0605V2	
270	242	270	17	17.5	7.5	GS0689V2	
280	252	280	17	17.5	7.5	GS0619V2	
300	272	300	17	17.5	7.5	GS0510V2	
320	292	320	17	17.5	7.5	GS0690V2	

SPGC TYPE

**SPECIAL PACKINGS
FOR PISTON SEALS**

**RAREFLON (PTFE) +
NITRILE RUBBER (NBR)**



- Please designate NOK Part number and type & size on your order.

(Example) • Type Dimensions SPGC 3 6 2.3

└── Type Sign └── Nominal Size of Packing
described in order of
inner diameter(d), outer diameter(D), and height(h)

• Part Number GS1000F0

- Please check the application range on pages 14 and 15 before selecting the type.

Material	NOK 31BF + NOK A305
-----------------	---------------------

SPGC TYPE

SPECIAL PACKINGS FOR PISTON SEALS

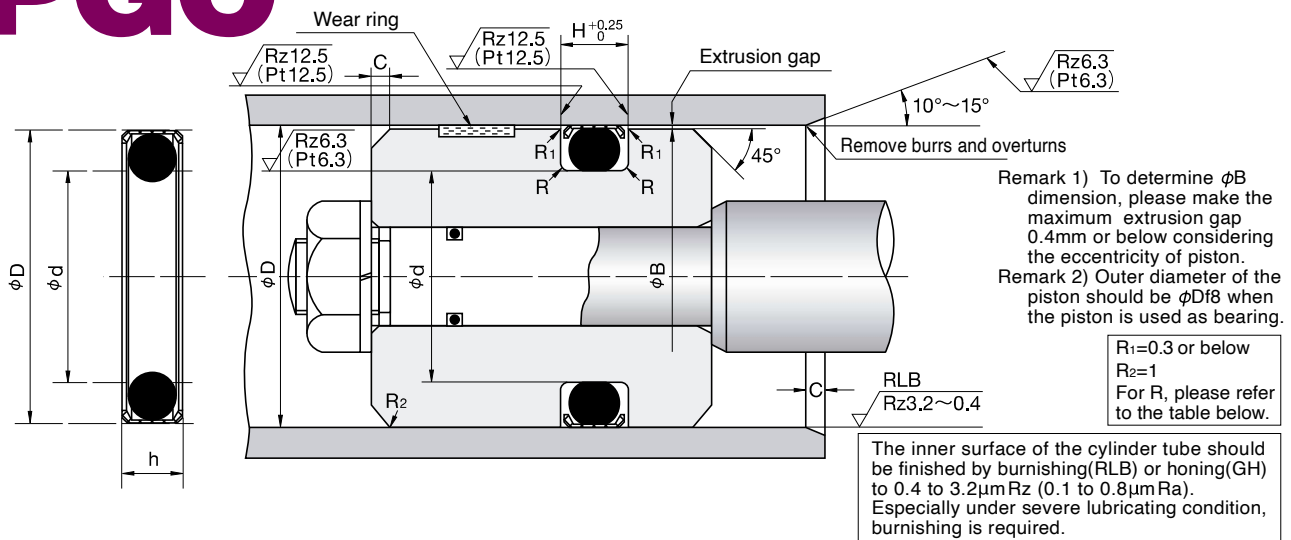

Nominal Number	Nominal Size of Packing			Housing dimensions				H	R	C	NOK Part Number
				For general hydraulic use		For pneumatic and hydraulic low-friction applications					
				phi d _{-0.05}	phi D ^{+0.05} ₀	phi d _{-0.05}	phi D ^{+0.05} ₀				
SPGC 6	3	6	2.3	3	6	2.5	6	2.5	0.3 or below	3~4	● GS1000F0
7	4	7	2.3	4	7	3.5	7	2.5	0.3 or below	3~4	● GS1001F0
8	5	8	2.3	5	8	4.5	8	2.5	0.3 or below	3~4	● GS1002F0
9	6	9	2.3	6	9	5.5	9	2.5	0.3 or below	3~4	● GS1003F0
10	7	10	2.3	7	10	6.5	10	2.5	0.3 or below	3~4	● GS1004F0
11	8	11	2.3	8	11	7.5	11	2.5	0.3 or below	3~4	● GS1005F0
12	9	12	2.3	9	12	8.5	12	2.5	0.3 or below	3~4	● GS1006F0
13	10	13	2.3	10	13	9.5	13	2.5	0.3 or below	3~4	● GS1007F0
Nominal Number	Nominal Size of Packing			Housing dimensions				H	R	C	NOK Part Number
				For general hydraulic use		For pneumatic and hydraulic low-friction applications					
				phi d _{-0.06}	phi D ^{+0.06} ₀	phi d _{-0.06}	phi D ^{+0.06} ₀				
SPGC 14	10	14	3	10	14	9.4	14	3.2	0.4 or below	4~5	● GS1008F0
15	11	15	3	11	15	10.4	15	3.2	0.4 or below	4~5	● GS1009F0
15.2	11.2	15.2	3	11.2	15.2	10.6	15.2	3.2	0.4 or below	4~5	● GS1010F0
16	12	16	3	12	16	11.4	16	3.2	0.4 or below	4~5	● GS1011F0
16.5	12.5	16.5	3	12.5	16.5	11.9	16.5	3.2	0.4 or below	4~5	● GS1012F0
18	14	18	3	14	18	13.4	18	3.2	0.4 or below	4~5	● GS1013F0
19	15	19	3	15	19	14.4	19	3.2	0.4 or below	4~5	● GS1014F0
20	16	20	3	16	20	15.4	20	3.2	0.4 or below	4~5	● GS1015F0
22	18	22	3	18	22	17.4	22	3.2	0.4 or below	4~5	● GS1016F0
24	20	24	3	20	24	19.4	24	3.2	0.4 or below	4~5	● GS1017F0
25	21	25	3	21	25	20.4	25	3.2	0.4 or below	4~5	● GS1018F0
26	22	26	3	22	26	21.4	26	3.2	0.4 or below	4~5	● GS1020F0
Nominal Number	Nominal Size of Packing			Housing dimensions				H	R	C	NOK Part Number
				For general hydraulic use		For pneumatic and hydraulic low-friction applications					
				phi d _{-0.08}	phi D ^{+0.08} ₀	phi d _{-0.08}	phi D ^{+0.08} ₀				
SPGC 28	22	28	4.4	22	28	21.4	28	4.7	0.7 or below	5~6	● GS1019F0
28.4	22.4	28.4	4.4	22.4	28.4	21.8	28.4	4.7	0.7 or below	5~6	● GS1021F0
30	24	30	4.4	24	30	23.4	30	4.7	0.7 or below	5~6	● GS1022F0
31	25	31	4.4	25	31	24.4	31	4.7	0.7 or below	5~6	● GS1023F0
31.5	25.5	31.5	4.4	25.5	31.5	24.9	31.5	4.7	0.7 or below	5~6	● GS1024F0
32	26	32	4.4	26	32	25.4	32	4.7	0.7 or below	5~6	● GS1025F0
34	28	34	4.4	28	34	27.4	34	4.7	0.7 or below	5~6	● GS1026F0
35	29	35	4.4	29	35	28.4	35	4.7	0.7 or below	5~6	● GS1027F0
35.5	29.5	35.5	4.4	29.5	35.5	28.9	35.5	4.7	0.7 or below	5~6	● GS1028F0
36	30	36	4.4	30	36	29.4	36	4.7	0.7 or below	5~6	● GS1029F0
37	31	37	4.4	31	37	30.4	37	4.7	0.7 or below	5~6	● GS1030F0
37.5	31.5	37.5	4.4	31.5	37.5	30.9	37.5	4.7	0.7 or below	5~6	● GS1031F0
38	32	38	4.4	32	38	31.4	38	4.7	0.7 or below	5~6	● GS1032F0
40	34	40	4.4	34	40	33.4	40	4.7	0.7 or below	5~6	● GS1033F0
41	35	41	4.4	35	41	34.4	41	4.7	0.7 or below	5~6	● GS1034F0
41.5	35.5	41.5	4.4	35.5	41.5	34.9	41.5	4.7	0.7 or below	5~6	● GS1035F0
42	36	42	4.4	36	42	35.4	42	4.7	0.7 or below	5~6	● GS1036F0

Remark) When using the packing with ●, provide separate grooves.

SPGC TYPE SPECIAL PACKINGS FOR PISTON SEALS

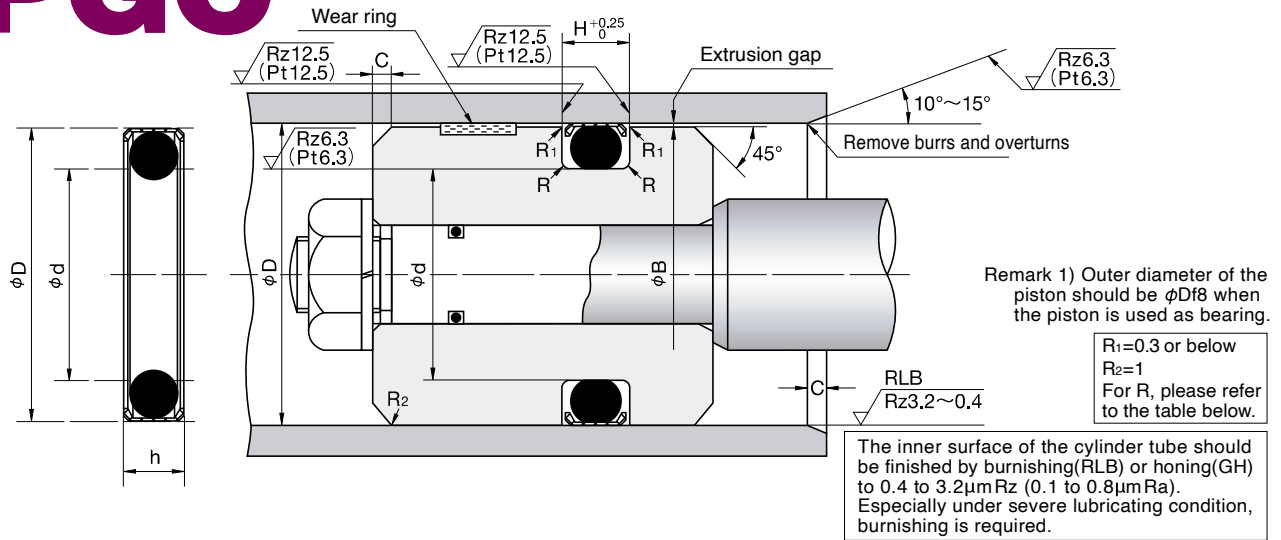

● The roughness is JIS B 0601 : 2001.
When regulation length cannot be kept, apply Pt.

Nominal Number	Nominal Size of Packing			Housing dimensions				H	R	C	NOK Part Number
				For general hydraulic use		For pneumatic and hydraulic low-friction applications					
				$\phi d_{-0.08}^0$	$\phi D_{+0.08}^0$	$\phi d_{-0.08}^0$	$\phi D_{+0.08}^0$				
SPGC 44	38	44	4.4	38	44	37.4	44	4.7	0.7 or below	5~6	● GS1037F0
45	39	45	4.4	39	45	38.4	45	4.7	0.7 or below	5~6	● GS1038F0
46	40	46	4.4	40	46	39.4	46	4.7	0.7 or below	5~6	● GS1039F0
47	41	47	4.4	41	47	40.4	47	4.7	0.7 or below	5~6	● GS1040F0
48	42	48	4.4	42	48	41.4	48	4.7	0.7 or below	5~6	● GS1041F0
50	44	50	4.4	44	50	43.4	50	4.7	0.7 or below	5~6	GS1042F0
51	45	51	4.4	45	51	44.4	51	4.7	0.7 or below	5~6	GS1043F0
52	46	52	4.4	46	52	45.4	52	4.7	0.7 or below	5~6	GS1044F0
54	48	54	4.4	48	54	47.4	54	4.7	0.7 or below	5~6	GS1046F0
55	49	55	4.4	49	55	48.4	55	4.7	0.7 or below	5~6	GS1047F0
56	50	56	4.4	50	56	49.4	56	4.7	0.7 or below	5~6	GS1049F0
Nominal Number	Nominal Size of Packing			Housing dimensions				H	R	C	NOK Part Number
				For general hydraulic use		For pneumatic and hydraulic low-friction applications					
				$\phi d_{-0.10}^0$	$\phi D_{+0.10}^0$	$\phi d_{-0.10}^0$	$\phi D_{+0.10}^0$				
SPGC 58	48	58	7	48	58	47.4	58	7.5	0.8 or below	6~8	GS1045F0
60	50	60	7	50	60	49.4	60	7.5	0.8 or below	6~8	GS1048F0
62	52	62	7	52	62	51.4	62	7.5	0.8 or below	6~8	GS1050F0
63	53	63	7	53	63	52.4	63	7.5	0.8 or below	6~8	GS1051F0
65	55	65	7	55	65	54.4	65	7.5	0.8 or below	6~8	GS1052F0
66	56	66	7	56	66	55.4	66	7.5	0.8 or below	6~8	GS1053F0
68	58	68	7	58	68	57.4	68	7.5	0.8 or below	6~8	GS1054F0
70	60	70	7	60	70	59.4	70	7.5	0.8 or below	6~8	GS1055F0
72	62	72	7	62	72	61.4	72	7.5	0.8 or below	6~8	GS1056F0
73	63	73	7	63	73	62.4	73	7.5	0.8 or below	6~8	GS1057F0
75	65	75	7	65	75	64.4	75	7.5	0.8 or below	6~8	GS1058F0
77	67	77	7	67	77	66.4	77	7.5	0.8 or below	6~8	GS1059F0
80	70	80	7	70	80	69.4	80	7.5	0.8 or below	6~8	GS1060F0
81	71	81	7	71	81	70.4	81	7.5	0.8 or below	6~8	GS1061F0
85	75	85	7	75	85	74.4	85	7.5	0.8 or below	6~8	GS1062F0
90	80	90	7	80	90	79.4	90	7.5	0.8 or below	6~8	GS1063F0
95	85	95	7	85	95	84.4	95	7.5	0.8 or below	6~8	GS1064F0
100	90	100	7	90	100	89.4	100	7.5	0.8 or below	6~8	GS1065F0
105	95	105	7	95	105	94.4	105	7.5	0.8 or below	6~8	GS1066F0
110	100	110	7	100	110	99.4	110	7.5	0.8 or below	6~8	GS1067F0
112	102	112	7	102	112	101.4	112	7.5	0.8 or below	6~8	GS1068F0
115	105	115	7	105	115	104.4	115	7.5	0.8 or below	6~8	GS1069F0
120	110	120	7	110	120	109.4	120	7.5	0.8 or below	6~8	GS1070F0
122	112	122	7	112	122	111.4	122	7.5	0.8 or below	6~8	GS1071F0
125	115	125	7	115	125	114.4	125	7.5	0.8 or below	6~8	GS1072F0
130	120	130	7	120	130	119.4	130	7.5	0.8 or below	6~8	GS1073F0
135	125	135	7	125	135	124.4	135	7.5	0.8 or below	6~8	GS1074F0
140	130	140	7	130	140	129.4	140	7.5	0.8 or below	6~8	GS1075F0
142	132	142	7	132	142	131.4	142	7.5	0.8 or below	6~8	GS1076F0

Remark) When using the packing with ●, provide separate grooves.

HOW TO DETERMINE B DIMENSION

To determine B dimension, please make the maximum extrusion gap 0.4mm or below considering the eccentricity of piston.

Nominal Number	Nominal Size of Packing			Housing dimensions							NOK Part Number
				For general hydraulic use		For pneumatic and hydraulic low-friction applications		H	R	C	
	d	D	h	$\phi d_{-0.10}^0$	$\phi D_0^{+0.10}$	$\phi d_{-0.10}^0$	$\phi D_0^{+0.10}$				
SPGC 145	135	145	7	135	145	134.4	145	7.5	0.8 or below	6~8	GS1077F0
150	140	150	7	140	150	139.4	150	7.5	0.8 or below	6~8	GS1078F0
155	145	155	7	145	155	144.4	155	7.5	0.8 or below	6~8	GS1079F0
160	150	160	7	150	160	149.4	160	7.5	0.8 or below	6~8	GS1081F0
165	150	165	10.5	150	165	149.4	165	11.0	0.8 or below	8~12	GS1080F0
170	155	170	10.5	155	170	154.4	170	11.0	0.8 or below	8~12	GS1082F0
175	160	175	10.5	160	175	159.4	175	11.0	0.8 or below	8~12	GS1083F0
180	165	180	10.5	165	180	164.4	180	11.0	0.8 or below	8~12	GS1084F0
185	170	185	10.5	170	185	169.4	185	11.0	0.8 or below	8~12	GS1085F0
190	175	190	10.5	175	190	174.4	190	11.0	0.8 or below	8~12	GS1086F0
195	180	195	10.5	180	195	179.4	195	11.0	0.8 or below	8~12	GS1087F0
200	185	200	10.5	185	200	184.4	200	11.0	0.8 or below	8~12	GS1088F0
205	190	205	10.5	190	205	189.4	205	11.0	0.8 or below	8~12	GS1089F0
210	195	210	10.5	195	210	194.4	210	11.0	0.8 or below	8~12	GS1090F0
215	200	215	10.5	200	215	199.4	215	11.0	0.8 or below	8~12	GS1091F0
220	205	220	10.5	205	220	204.4	220	11.0	0.8 or below	8~12	GS1092F0
224	209	224	10.5	209	224	208.4	224	11.0	0.8 or below	8~12	GS1093F0
225	210	225	10.5	210	225	209.4	225	11.0	0.8 or below	8~12	GS1094F0
230	215	230	10.5	215	230	214.4	230	11.0	0.8 or below	8~12	GS1095F0
235	220	235	10.5	220	235	219.4	235	11.0	0.8 or below	8~12	GS1096F0
240	225	240	10.5	225	240	224.4	240	11.0	0.8 or below	8~12	GS1097F0
245	230	245	10.5	230	245	229.4	245	11.0	0.8 or below	8~12	GS1098F0
250	235	250	10.5	235	250	234.4	250	11.0	0.8 or below	8~12	GS1099F0
255	240	255	10.5	240	255	239.4	255	11.0	0.8 or below	8~12	GS1100F0
260	245	260	10.5	245	260	244.4	260	11.0	0.8 or below	8~12	GS1101F0
265	250	265	10.5	250	265	249.4	265	11.0	0.8 or below	8~12	GS1102F0
270	255	270	10.5	255	270	254.4	270	11.0	0.8 or below	8~12	GS1103F0
275	260	275	10.5	260	275	259.4	275	11.0	0.8 or below	8~12	GS1104F0
280	265	280	10.5	265	280	264.4	280	11.0	0.8 or below	8~12	GS1105F0
285	270	285	10.5	270	285	269.4	285	11.0	0.8 or below	8~12	GS1106F0
290	275	290	10.5	275	290	274.4	290	11.0	0.8 or below	8~12	GS1107F0
295	280	295	10.5	280	295	279.4	295	11.0	0.8 or below	8~12	GS1108F0
300	285	300	10.5	285	300	284.4	300	11.0	0.8 or below	8~12	GS1109F0
305	290	305	10.5	290	305	289.4	305	11.0	0.8 or below	8~12	GS1110F0
310	295	310	10.5	295	310	294.4	310	11.0	0.8 or below	8~12	GS1111F0
315	300	315	10.5	300	315	299.4	315	11.0	0.8 or below	8~12	GS1112F0
330	315	330	10.5	315	330	314.4	330	11.0	0.8 or below	8~12	GS1113F0
335	320	335	10.5	320	335	319.4	335	11.0	0.8 or below	8~12	GS1114F0
350	335	350	10.5	335	350	334.4	350	11.0	0.8 or below	8~12	GS1115F0
355	340	355	10.5	340	355	339.4	355	11.0	0.8 or below	8~12	GS1116F0
370	355	370	10.5	355	370	354.4	370	11.0	0.8 or below	8~12	GS1117F0
375	360	375	10.5	360	375	359.4	375	11.0	0.8 or below	8~12	GS1118F0
390	375	390	10.5	375	390	374.4	390	11.0	0.8 or below	8~12	GS1119F0
400	385	400	10.5	385	400	384.4	400	11.0	0.8 or below	8~12	GS1120F0

CPI TYPE

SPECIAL PACKINGS FOR PISTON SEALS IRON RUBBER (PUR)



E
DIMENSION
CPI

- Please designate NOK Part number and type & size on your order.

(Example) • Type Dimensions CPI 25 10 2.5 10

└── Type Sign

└── Nominal Size of Packing
described in order of
outer diameter(D), height(h), thickness(t), and inner diameter(d)

• Part Number FC0013C0

- Please check the application range on pages 14 and 15 before selecting the type.

Material	NOK U801
-----------------	----------

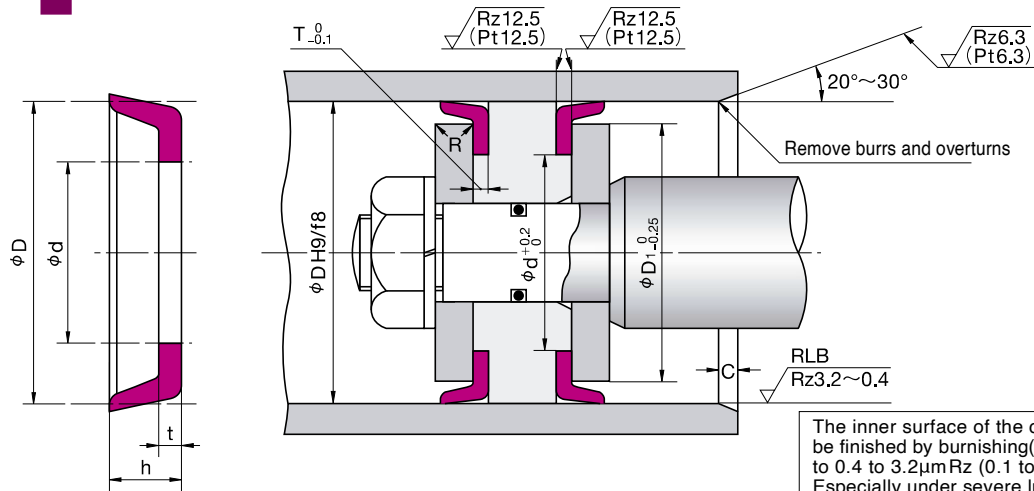

The inner surface of the cylinder tube should be finished by burnishing (RLB) or honing (GH) to 0.4 to 3.2 μm Rz (0.1 to 0.8 μm Ra). Especially under severe lubricating condition, burnishing is required.

- The roughness is JIS B 0601 : 2001.
When regulation length cannot be kept, apply Pt.

Nominal Size of Packing, and Housing dimensions								NOK Part Number
D	h	t	d	φD	T	R	C	
25	10	2.5	10	17	2.4	1.5	3	FC0013C0
28	10	2.5	10	20	2.4	1.5	3	FC0015C0
30	10	2.5	12	22	2.4	1.5	3	FC0020C0
31.5	10	2.5	14	23.5	2.4	1.5	3	FC0022C0
35	10	2.5	16	27	2.4	1.5	3	FC0026C0
35.5	10	2.5	16	27.5	2.4	1.5	3	FC0398C0
40	10	2.5	20	32	2.4	1.5	3	FC0035C0
45	12	3	20	36	2.9	2	3	FC0046C0
50	12	3	22	41	2.9	2	3	FC0055C0
53	12	3	25	44	2.9	2	3	FC0064C0
55	12	3	25	46	2.9	2	3	FC0068C0
56	12	3	25	47	2.9	2	3	FC0070C0
60	12	3	30	51	2.9	2	3	FC0077C0
63	12	3	35	54	2.9	2	3	FC0090C0
65	12	3	35	56	2.9	2	3.5	FC0095C0
67	12	3	38	58	2.9	2	3.5	FC0102C1
70	12	3	38	61	2.9	2	3.5	FC0106C0
71	12	3	40	62	2.9	2	3.5	FC0114C0
75	12	3	40	66	2.9	2	3.5	FC0117C0
80	16	4	40	69	3.8	3	4	FC0134C0
85	16	4	45	74	3.8	3	4	FC0142C0
90	16	4	50	79	3.8	3	4	FC0157C0
95	16	4	55	84	3.8	3	4	FC0164C0
100	16	4	55	89	3.8	3	4	FC0174C0
105	16	4	60	94	3.8	3	4	FC0187C0
106	16	4	60	95	3.8	3	4	FC0189C0
110	16	4	60	99	3.8	3	4	FC0195C0
112	16	4	65	101	3.8	3	4	FC0199C0
118	16	4	70	107	3.8	3	4	FC0205C0
120	16	4	70	109	3.8	3	4	FC0207C0
125	20	5	75	111	4.8	4	5.5	FC0222C0
130	20	5	80	116	4.8	4	5.5	FC0230C0
132	20	5	85	118	4.8	4	5.5	FC0233C1
140	20	5	90	126	4.8	4	5.5	FC0245C1
150	20	5	100	136	4.8	4	5.5	FC0255C1
160	20	5	110	146	4.8	4	5.5	FC0275C0
170	20	5	120	156	4.8	4	5.5	FC0279C0
180	20	5	130	166	4.8	4	5.5	FC0282C1
190	20	5	140	176	4.8	4	5.5	FC0289C0
200	20	5	150	186	4.8	4	5.5	FC0293C0
224	20	5	180	210	4.8	4	5.5	FC0314C0
250	20	5	200	236	4.8	4	5.5	FC0321C0
280	20	5	230	266	4.8	4	6.5	FC0337C0
300	20	5	250	286	4.8	4	7	FC0344C1

CPH TYPE

SPECIAL PACKINGS
FOR PISTON SEALS
NITRILE RUBBER (NBR)



E
DIMENSION
CPH

- Please designate NOK Part number and type & size on your order.

(Example) · Type Dimensions CPH 30 8 2.5 13

Type Sign

Nominal Size of Packing
described in order of
outer diameter(D), height(h), thickness(t), and inner diameter(d)

· Part Number CC0019C3

- Please check the application range on pages 14 and 15 before selecting the type.

Material	NOK A102 NOK A103 NOK A104 NOK A505
-----------------	--

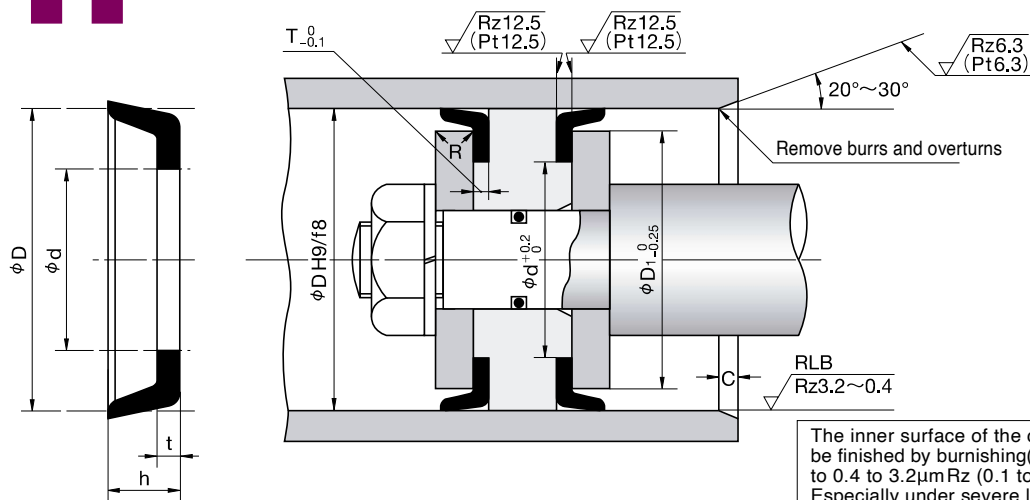

The inner surface of the cylinder tube should be finished by burnishing (RLB) or honing (GH) to 0.4 to 3.2μm Rz (0.1 to 0.8μm Ra). Especially under severe lubricating condition, burnishing is required.

● The roughness is JIS B 0601 : 2001.
When regulation length cannot be kept, apply Pt.

Nominal Size of Packing, and Housing dimensions								NOK	NOK Rubber
D	h	t	d	φD ₁	T	R	C	Part Number	material Sign
30	8	2.5	13	23	2.5	1.5	7	CC0019C3	A104
30	10	2.5	12	23.5	2.5	1.5	7	CC0020C0	A103
30	10	2.5	15	23	2.5	1.5	7	CC0020C1	A102
35	10	2.5	18	28.5	2.5	1.5	7	CC0026C0	A102
40	8	2.5	16	33	2.5	1.5	7	CC0034C1	A104
40	10	2.5	20	33.5	2.5	1.5	7	CC0035C0	A102
42	12	3	23	34	3	2	7	CC0040C0	A505
45	10	2.5	25	38.5	2.5	2	7	CC0044C0	A102
50	12	3	25	41.5	3	2	7	CC0055C1	A104
55	10	3	40	48	3	2	7	CC0067C0	A103
60	8	2.5	40.5	54	2.5	2	7	CC0074C0	A103
60	12	3	30	51	3	2	7	CC0077C0	A505
65	13	3.5	34.5	56	3.5	2	7	CC0096C0	A104
70	12	3	38	62	3	2	7	CC0106C2	A505
75	12	3	38	66	3	2	7	CC0117C1	A104
80	15	4	40	70	4	3	7	CC0132C0	A505
80	16	4	40	69	4	3	7	CC0134C0	A102
90	15	4.3	38	80	4.3	3	8	CC0156C0	A505
90	16	4	45	79.5	4	3	8	CC0157C0	A102
90	17	5	50	77	5	3	8	CC0159C0	A104
100	15	4.3	38	88	4.3	3	8	CC0171C0	A104
100	16	4	50	89	4	3	8	CC0174C5	A104
100	16	4	55	89	4	3	8	CC0174C4	A505
120	16	4	60	109	4	3	8	CC0207C0	A102
120	16	4	70	109	4	3	8	CC0207C1	A104
125	16	5	75	115	5	4	8	CC0219C0	A104
130	20	5	80	116	5	4	8	CC0230C1	A104
150	20	5	75	136	5	4	11	CC0255C0	A102
150	20	5	100	138	5	4	11	CC0255C2	A505
180	20	5	90	166.5	5	4	11	CC0282C0	A102
180	25	5	80	166	5	4	11	CC0285C0	A104
200	20	5	150	187	5	4	11	CC0293C5	A505
205	23	4	134	190	4	4	11	CC0303C1	A103
257	22	5.5	192	245	5.5	4	14	CC0328C1	A103

E
DIMENSION
CPH

IDI TYPE

SPECIAL PACKINGS FOR ROD SEALS IRON RUBBER (PUR)



● Please designate NOK Part number and type & size on your order.

(Example) Order for the packing as a single piece

· Type Dimensions	<u>IDI</u>	<u>6.3</u>	<u>14.3</u>	<u>5</u>	
	└─ Type Sign	└─ Nominal Size of Packing described in order of inner diameter(d), outer diameter(D), and height(h)			
· Part Number	FU0021F0				

※ When placing orders for backup rings used in combination with packing, designate the NOK part number and the model size.

· Type Dimensions	<u>BRT3</u>	<u>6.3</u>	<u>14.3</u>	<u>2</u>	
	└─ Type Sign	└─ Nominal Size of Backup ring described in order of inner diameter(d), outer diameter(D), and thickness(t)*			
· Part Number	GN7259V0				*t = H _B - H _A (Housing dimensions)

● Please check the application range on pages 14 and 15 before selecting the type.

Material	NOK U801
-----------------	----------

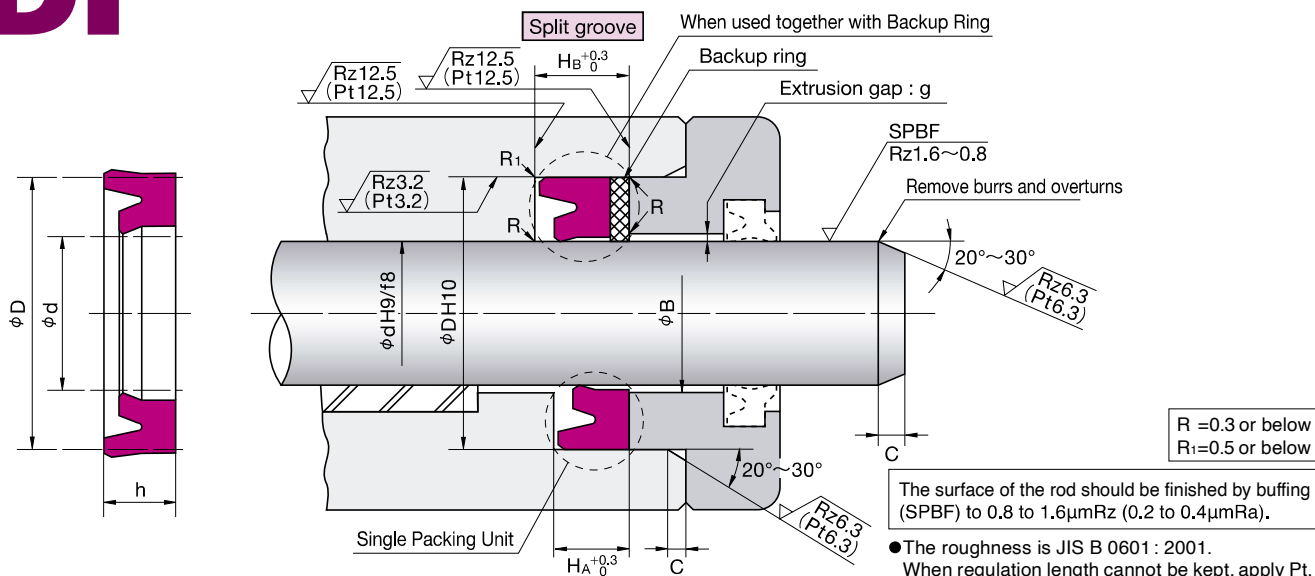

Nominal Size of Packing, and Housing dimensions						Packing Part Number	Combination Backup Ring Part Number	
d	D	h	H _A	H _B	C		BRT3 (Endless) 19YF	BRN3 (Endless) 80NP
6.3	14.3	5	5.7	7.7	2.5	※FU0021F0	GN7259V0	GN9822O0
6.3	16.3	6	7	9	2.5	※FU0022F0	GN0720V0	GN9823O0
6.3	16.3	7.5	8.5	10.5	2.5	FU0023F0	GN0720V0	GN9823O0
6.3	16.3	8	9	11	2.5	FU0024F0	GN0720V0	GN9823O0
8	16	5	5.7	7.7	2.5	※FU0039F0	GN7260V0	GN9824O0
8	18	6	7	9	2.5	※FU0041F0	GN0725V0	GN9101O1
8	18	7.5	8.5	10.5	2.5	FU0042F0	GN0725V0	GN9101O1
8	18	8	9	11	2.5	FU0043F0	GN0725V0	GN9101O1
9	17	5	5.7	7.7	2.5	※FU0051F0	GN7261V0	GN9825O0
9	19	6	7	9	2.5	※FU0052F0	GN0728V0	GN9826O0
9	19	7.5	8.5	10.5	2.5	FU0053F0	GN0728V0	GN9826O0
9	19	8	9	11	2.5	FU0054F0	GN0728V0	GN9826O0
10	18	5	5.7	7.7	2.5	※FU0064F0	GN7262V0	GN9827O0
10	20	6	7	9	2.5	※FU0066F0	GN0733V0	GN9102O1
10	20	7.5	8.5	10.5	2.5	FU0068F0	GN0733V0	GN9102O1
10	20	8	9	11	2.5	FU0069F0	GN0733V0	GN9102O1
11.2	19.2	5	5.7	7.7	2.5	※FU0078F0	GN7236V0	GN9792O0
11.2	21.2	6	7	9	2.5	※FU0079F0	GN0736V0	GN9828O0
11.2	21.2	7.5	8.5	10.5	2.5	FU0080F0	GN0736V0	GN9828O0
11.2	21.2	8	9	11	2.5	FU0081F0	GN0736V0	GN9828O0
12.5	20.5	5	5.7	7.7	2.5	※FU0098F0	GN7263V0	GN9829O0
12.5	22.5	6	7	9	2.5	※FU0100F0	GN0741V0	GN9830O0
12.5	22.5	7.5	8.5	10.5	2.5	FU0101F0	GN0741V0	GN9830O0
12.5	22.5	8	9	11	2.5	FU0102F0	GN0741V0	GN9830O0
14	22	5	5.7	7.7	2.5	※FU0116F0	GN7238V0	GN9794O0
14	24	6	7	9	2.5	※FU0120F0	GN0745V0	GN9103O1
14	24	7.5	8.5	10.5	2.5	FU0121F0	GN0745V0	GN9103O1
14	24	8	9	11	2.5	FU0122F0	GN0745V0	GN9103O1
15	23	5	5.7	7.7	2.5	※FU0131F0	GN7264V0	GN9831O0
15	25	6	7	9	2.5	※FU0134F0	GN0749V0	GN9738O1
15	25	8	9	11	2.5	FU0135F0	GN0749V0	GN9738O1
15	28	8	9	11	3.5	FU0136F0	GN6445V0	GN9104O1
15	28	10	11	13	3.5	FU0137F0	GN6445V0	GN9104O1
16	24	5	5.7	7.7	2.5	※FU0150F0	GN7265V0	GN9832O0
16	26	6	7	9	2.5	※FU0155F0	GN0751V0	GN9105O1
16	26	7.5	8.5	10.5	2.5	FU0156F0	GN0751V0	GN9105O1
16	26	8	9	11	2.5	FU0157F0	GN0751V0	GN9105O1
18	28	6	7	9	2.5	※FU0181F0	GN0757V0	GN9833O0
18	28	8	9	11	2.5	FU0182F0	GN0757V0	GN9833O0
18	31	8	9	11	3.5	FU0185F0	GN6446V0	GN9107O1
18	31	10	11	13	3.5	FU0186F0	GN6446V0	GN9107O1

※ The resisting pressure limit applies to the ISI type.

HOW TO DETERMINE B DIMENSION

■ When using backup ring

Please determine B dimension according to the table below. If you require smaller B dimension because of the cylinder configuration, please consult NOK.

Maximum Service Pressure	14MPa	21MPa	35MPa
Material of Backup ring	19YF		
B Dimension	$B \leq \phi d + 1.0$	$B \leq \phi d + 0.5$	$B \leq \phi d + 0.2$
Maximum Service Pressure	35MPa	42MPa	70MPa
Material of Backup ring	80NP		
B Dimension	$B \leq \phi d + 0.8$	$B \leq \phi d + 0.4$	$B \leq \phi d + 0.2$

■ When not using backup ring

To determine B dimension, please refer to the graph in the right for the maximum extrusion gap (one side) considering the eccentricity of operating condition of the piston.

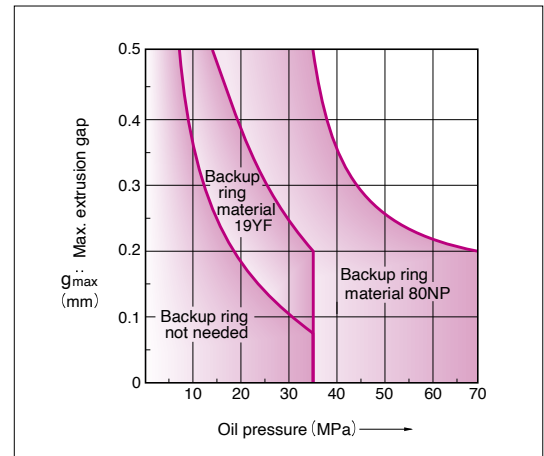

Nominal Size of Packing, and Housing dimensions						Packing Part Number	Combination Backup Ring Part Number	
d	D	h	H _A	H _B	C		BRT3 (Endless)	BRN3 (Endless)
							19YF	80NP
20	30	6	7	9	3.5	※FU0214F0	GN0762V0	GN9109O1
20	30	8	9	11	3.5	FU0215F0	GN0762V0	GN9109O1
20	33	8	9	11	3.5	FU0220F0	GN6448V0	GN9110O1
20	33	10	11	13	3.5	FU0221F0	GN6448V0	GN9110O1
22	35	10	11	13	3.5	FU0249F0	GN6449V0	GN9111O1
22.4	32.4	6	7	9	3.5	※FU0262F0	GN0771V0	GN9834O0
22.4	32.4	8	9	11	3.5	FU0263F0	GN0771V0	GN9834O0
22.4	35.4	8	9	11	3.5	FU0264F0	GN6017V0	GN9798O0
22.4	35.4	10	11	13	3.5	FU0265F0	GN6017V0	GN9798O0
25	35	6	7	9	3.5	※FU0279F0	GN0781V0	GN9115O1
25	35	8	9	11	3.5	FU0282F0	GN0781V0	GN9115O1
25	38	8	9	11	3.5	FU0287F0	GN6453V0	GN9116O1
25	38	10	11	13	3.5	FU0288F0	GN6453V0	GN9116O1
25	40	9	10	12	4	FU0291F0	GN6591V0	GN9800O0
25	40	10	11	13	4	FU0292F0	GN6591V0	GN9800O0
27	40	10	11	14	4	FU2130F0	GN6455V0	GN9118O1
28	38	6	7	10	4	※FU0322F0	GN7268V0	GN9835O0
28	38	8	9	12	4	FU0323F0	GN7268V0	GN9835O0
28	41	8	9	12	4	FU0334F0	GN6458V0	GN9121O1
28	41	10	11	14	4	FU0335F0	GN6458V0	GN9121O1
28	43	9	10	13	4	FU0339F0	GN0791V0	GN9836O0
28	43	10	11	14	4	FU0340F0	GN0791V0	GN9836O0
30	40	8	9	12	4	FU0359F0	GN6361V0	GN9122O1
30	43	10	11	14	4	FU0364F0	GN6459V0	GN9123O1
30	45	9	10	13	4	FU0367F0	GN7061V0	GN9801O0
30	45	10	11	14	4	FU0368F0	GN7061V0	GN9801O0
31.5	41.5	8	9	12	4	FU0383F0	GN6460V0	GN9124O1
31.5	44.5	8	9	12	4	FU0384F0	GN6461V0	GN9125O1
31.5	44.5	10	11	14	4	FU0385F0	GN6461V0	GN9125O1
31.5	46.5	9	10	13	4	FU0386F0	GN0805V0	GN9837O0
31.5	46.5	10	11	14	4	FU0387F0	GN0805V0	GN9837O0
34	50	12	13	16	4	FU0408F0	GN6462V0	GN9126O1
35	45	8	9	12	4	FU0427F0	GN6463V0	GN9127O1
35	50	9	10	13	4	FU0436F0	GN0816V0	GN9128O1
35	50	10	11	14	4	FU0437F0	GN0816V0	GN9128O1
35	50	12	13	16	4	FU0438F0	GN0816V0	GN9128O1
35.5	45.5	8	9	12	4	FU0453F0	GN7271V0	GN9788O1
35.5	50.5	9	10	13	4	FU0455F0	GN0820V0	GN9954O0
35.5	50.5	10	11	14	4	FU0456F0	GN0820V0	GN9954O0
35.5	51.5	10	11	14	4	FU0457F0	GN6330V0	GN9130O1
35.5	51.5	12	13	16	4	FU0458F0	GN6330V0	GN9130O1

※ The resisting pressure limit applies to the ISI type.

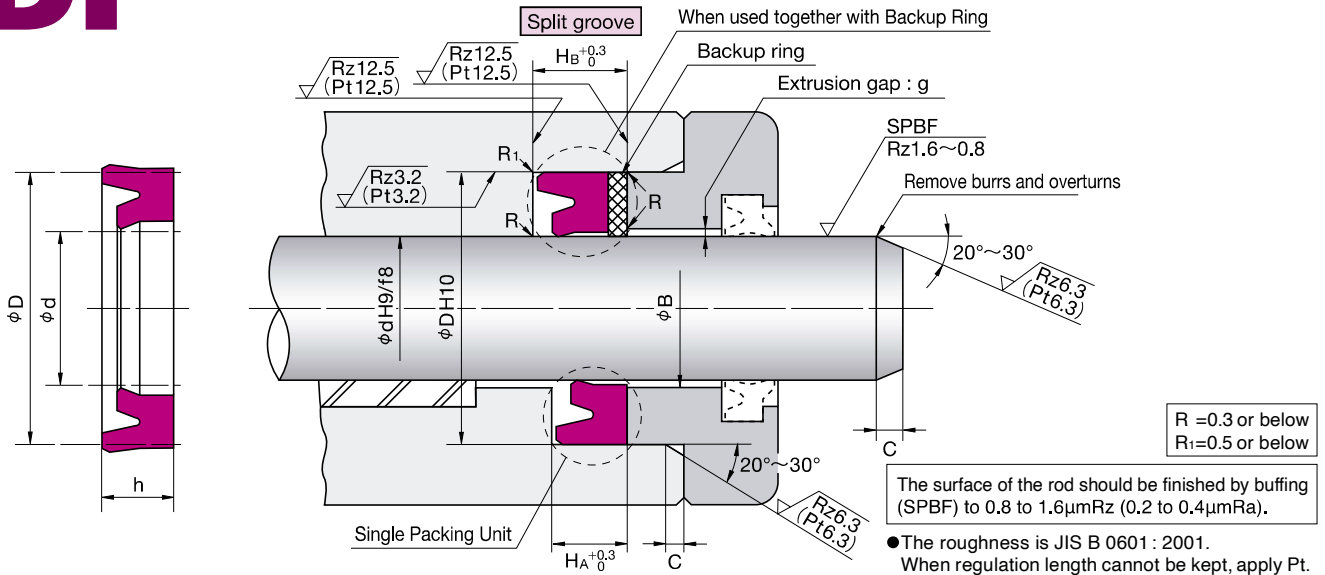

Nominal Size of Packing, and Housing dimensions						Packing Part Number	Combination Backup Ring Part Number	
d	D	h	H _A	H _B	C		BRT3 (Endless) 19YF	BRN3 (Endless) 80NP
40	50	8	9	12	4	FU0498F0	GN6465V0	GN9131O1
40	55	9	10	13	4	FU0504F0	GN6759V0	GN9948O0
40	55	10	11	14	4	FU0505F0	GN6759V0	GN9948O0
40	56	10	11	14	4	FU0508F0	GN6466V0	GN9132O1
40	56	12	13	16	4	FU0509F0	GN6466V0	GN9132O1
45	55	8	9	12	4	FU0569F0	GN6467V0	GN9133O1
45	60	9	10	13	4	FU0575F0	GN0845V0	GN9950O0
45	60	10	11	14	4	FU0577F0	GN0845V0	GN9950O0
45	61	10	11	14	4	FU0579F0	GN6469V0	GN9135O1
45	61	12	13	16	4	FU0580F0	GN6469V0	GN9135O1
47	63	12	13	16	4	FU0591F0	GN6471V0	GN9137O1
50	60	8	9	12	4	FU0620F0	GN6302V0	GN9138O1
50	65	9	10	13	4	FU0630F0	GN6439V0	GN9952O0
50	65	10	11	14	4	FU0631F0	GN6439V0	GN9952O0
50	66	10	11	14	4	FU0634F0	GN6329V0	GN9139O1
50	66	12	13	16	4	FU0635F0	GN6329V0	GN9139O1
50	70	12	13	16	4	FU0639F0	GN6592V0	GN9529O0
53	69	12	13	16	4	FU0682F0	GN7008V0	GN9803O0
55	65	8	9	12	4	FU0696F0	GN6472V0	GN9141O1
55	70	9	10	13	4	FU0700F0	GN6408V0	GN9804O0
55	70	10	11	14	4	FU0701F0	GN6408V0	GN9804O0
55	71	10	11	14	4	FU0703F0	GN6473V0	GN9142O1
55	71	12	13	16	4	FU0704F0	GN6473V0	GN9142O1
55	75	12	13	16	4	FU0708F0	GN7249V0	GN9807O0
56	66	8	9	12	4	FU0723F0	GN6474V0	GN9143O1
56	71	9	10	13	4	FU0724F0	GN7247V0	GN9806O0
56	71	10	11	14	4	FU0725F0	GN7247V0	GN9806O0
56	72	10	11	14	4	FU0726F0	GN7009V0	GN9838O0
56	72	12	13	16	4	FU0727F0	GN7009V0	GN9838O0
56	76	12	13	16	4	FU0728F0	GN0877V0	GN9839O0
60	70	8	9	12	4	FU0747F0	GN6444V0	GN9144O1
60	75	9	10	13	4	FU0753F0	GN6363V0	GN9808O0
60	75	10	11	14	4	FU0754F0	GN6363V0	GN9808O0
60	76	10	11	14	4	FU0756F0	GN6476V0	GN9146O1
60	76	12	13	16	4	FU0757F0	GN6476V0	GN9146O1
60	80	12	13	16	4	FU0761F0	GN0886V1	GN9953O0
63	73	8	9	12	4	FU0787F0	GN6477V0	GN9147O1
63	78	9	10	13	4	FU0788F0	GN6304V0	GN9840O0
63	78	10	11	14	4	FU0789F0	GN6304V0	GN9840O0
63	79	10	11	14	4	FU0790F0	GN7010V0	GN9841O0
63	79	12	13	16	4	FU0791F0	GN7010V0	GN9841O0
63	83	12	13	16	4	FU0793F0	GN0893V1	GN9842O0

E DIMENSION IDI

HOW TO DETERMINE B DIMENSION

■ When using backup ring

Please determine B dimension according to the table below. If you require smaller B dimension because of the cylinder configuration, please consult NOK.

Maximum Service Pressure	14MPa	21MPa	35MPa
Material of Backup ring	19YF		
B Dimension	$B \leq \phi d + 1.0$	$B \leq \phi d + 0.5$	$B \leq \phi d + 0.2$

Maximum Service Pressure	35MPa	42MPa	70MPa
Material of Backup ring	80NP		
B Dimension	$B \leq \phi d + 0.8$	$B \leq \phi d + 0.4$	$B \leq \phi d + 0.2$

■ When not using backup ring

To determine B dimension, please refer to the graph in the right for the maximum extrusion gap (one side) considering the eccentricity of operating condition of the piston.

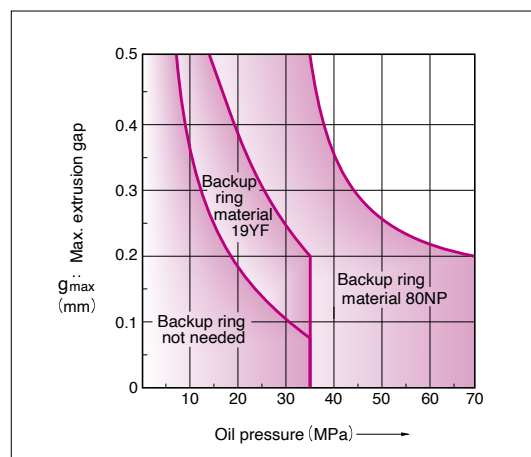

Nominal Size of Packing, and Housing dimensions						Packing Part Number	Combination Backup Ring Part Number	
d	D	h	H _A	H _B	C		BRT3 (Endless)	BRN3 (Endless)
							19YF	80NP
64	80	12	13	16	4	FU2131F0	GN6478V0	GN9148O1
65	75	8	9	12	5	FU0810F0	GN6479V0	GN9149O1
65	80	9	10	13	5	FU0815F0	GN6364V0	GN9754O1
65	80	12	13	16	5	FU0816F0	GN6364V0	GN9754O1
65	85	12	13	16	5	FU0819F0	GN0899V0	GN9810O0
67	82	9	10	13	5	FU0830F0	GN7273V0	GN9843O0
67	87	15	16	19	5	FU0832F0	GN0904V0	GN9844O0
70	80	8	9	12	5	FU0850F0	GN6362V1	GN9092O1
70	85	9	10	13	5	FU0857F0	GN6442V0	GN9411O0
70	85	10	11	14	5	FU0858F0	GN6442V0	GN9411O0
70	90	12	13	16	5	FU0862F0	GN0910V0	GN9151O1
70	90	15	16	19	5	FU0864F0	GN0910V0	GN9151O1
71	81	8	9	12	5	FU0881F0	GN6482V0	GN9153O1
71	86	9	10	13	5	FU0882F0	GN6603V0	GN9845O0
71	86	10	11	14	5	FU0883F0	GN6603V0	GN9845O0
71	91	12	13	16	5	FU0884F0	GN0914V0	GN9846O0
71	91	15	16	19	5	FU0885F0	GN0914V0	GN9846O0
75	85	8	9	12	5	FU0903F0	GN6729V0	GN9241O1
75	90	9	10	13	5	FU0906F0	GN6443V0	GN9757O1
75	90	10	11	14	5	FU0907F0	GN6443V0	GN9757O1
75	95	12	13	16	5	FU0910F0	GN0920V0	GN9154O1
75	95	15	16	19	5	FU0911F0	GN0920V0	GN9154O1
80	90	8	9	12	5	FU0940F0	GN6483V0	GN9155O1
80	95	9	10	13	5	FU0942F0	GN6898V0	GN9582O0
80	95	10	11	14	5	FU0943F0	GN6898V0	GN9582O0
80	100	12	13	16	5	FU0948F0	GN0927V0	GN9156O1
80	100	15	16	19	5	FU0949F0	GN0927V0	GN9156O1
85	100	10	11	14	5	FU0985F0	GN6484V0	GN9091O1
85	105	12	13	16	5	FU0989F0	GN0932V0	GN9157O1
85	105	15	16	19	5	FU0990F0	GN0932V0	GN9157O1
90	105	10	11	14	5	FU1025F0	GN6485V0	GN9158O1
90	110	12	13	16	5	FU1030F1	GN0939V0	GN9159O1
90	110	15	16	19	5	FU1031F0	GN0939V0	GN9159O1
95	110	10	11	14	5	FU1052F0	GN6486V0	GN9160O1
95	115	12	13	16	5	FU1056F0	GN0945V0	GN9161O1
95	115	15	16	19	5	FU1057F0	GN0945V0	GN9161O1

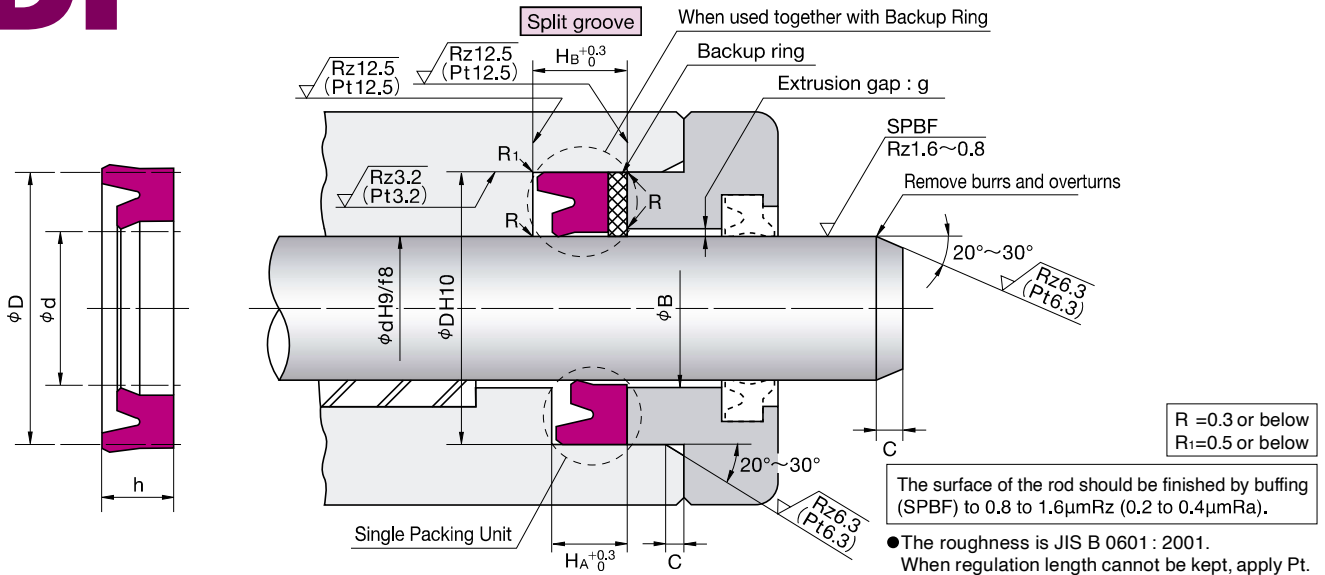

Nominal Size of Packing, and Housing dimensions						Packing Part Number	Combination Backup Ring Part Number	
d	D	h	H _A	H _B	C		BRT3 (Endless) 19YF	BRN3 (Endless) 80NP
100	115	10	11	14	5	FU1083F0	GN6488V0	GN9163O1
100	120	12	13	16	5	FU1089F0	GN0952V0	GN9164O1
100	120	15	16	19	5	FU1091F0	GN0952V0	GN9164O1
105	120	10	11	14	5	FU1126F0	GN6684V0	GN9589O1
105	125	15	16	19	5	FU1129F0	GN0959V0	GN9165O1
105	125	16	17	20	5	FU1130F0	GN0959V0	GN9165O1
106	121	10	11	14	5	FU1137F0	GN7274V0	GN9789O1
106	126	15	16	19	5	FU1138F0	GN0961V0	GN9847O0
106	126	16	17	20	5	FU1139F0	GN0961V0	GN9847O0
110	125	10	11	14	5	FU1158F0	GN6761V0	GN9430O1
110	130	15	16	19	5	FU1165F0	GN6790V0	GN9694O0
110	130	16	17	20	5	FU1166F0	GN6790V0	GN9694O0
112	127	9	10	13	5	FU1180F0	GN7275V0	GN9848O0
112	127	10	11	14	5	FU1181F0	GN7275V0	GN9848O0
112	132	15	16	19	5	FU1182F0	GN0970V0	GN9168O1
112	132	16	17	20	5	FU1183F0	GN0970V0	GN9168O1
118	133	10	11	14	5	FU1206F0	GN7276V0	GN9790O1
118	138	15	16	19	5	FU1207F0	GN0978V0	GN9849O0
118	138	16	17	20	5	FU1208F0	GN0978V0	GN9849O0
120	135	10	11	14	5	FU1221F0	GN6374V0	GN9768O0
120	140	15	16	19	5	FU1224F0	GN0982V0	GN9169O1
120	140	16	17	20	5	FU1225F0	GN0982V0	GN9169O1
125	140	10	11	14	6.5	FU1253F0	GN6491V0	GN9170O1
125	145	12	13	16	6.5	FU1256F0	GN0986V0	GN9850O0
125	145	16	17	20	6.5	FU1258F0	GN0986V0	GN9850O0
125	150	19	20	23	6.5	FU2132F0	GN6135V0	GN9171O1
125	150	20	21	24	6.5	FU1260F0	GN6135V0	GN9171O1
130	145	10	11	14	6.5	FU1281F0	GN6954V0	GN9742O0
130	150	12	13	16	6.5	FU1283F0	GN6925V0	GN9335O1
130	150	16	17	20	6.5	FU1285F0	GN6925V0	GN9335O1
132	157	20	21	24	6.5	FU1295F0	GN7013V0	GN9813O0
135	160	19	20	23	6.5	FU2133F0	GN6492V0	GN9172O1
135	160	20	21	24	6.5	FU2179F0	GN6492V0	GN9172O1
140	155	10	11	14	6.5	FU1324F0	GN6728V1	GN9410O1
140	160	12	13	16	6.5	FU1325F0	GN1002V0	GN9668O0
140	160	16	17	20	6.5	FU1328F0	GN1002V0	GN9668O0
140	165	19	20	23	6.5	FU1332F0	GN6494V0	GN9174O1
140	165	20	21	24	6.5	FU1333F0	GN6494V0	GN9174O1
145	170	19	20	23	6.5	FU2134F0	GN6496V0	GN9176O1
145	170	20	21	24	6.5	FU2180F0	GN6496V0	GN9176O1

E DIMENSION IDI

HOW TO DETERMINE B DIMENSION

■ When using backup ring

Please determine B dimension according to the table below. If you require smaller B dimension because of the cylinder configuration, please consult NOK.

Maximum Service Pressure	14MPa	21MPa	35MPa
Material of Backup ring	19YF		
B Dimension	$B \leq \phi d + 1.0$	$B \leq \phi d + 0.5$	$B \leq \phi d + 0.2$

Maximum Service Pressure	35MPa	42MPa	70MPa
Material of Backup ring	80NP		
B Dimension	$B \leq \phi d + 0.8$	$B \leq \phi d + 0.4$	$B \leq \phi d + 0.2$

■ When not using backup ring

To determine B dimension, please refer to the graph in the right for the maximum extrusion gap (one side) considering the eccentricity of operating condition of the piston.

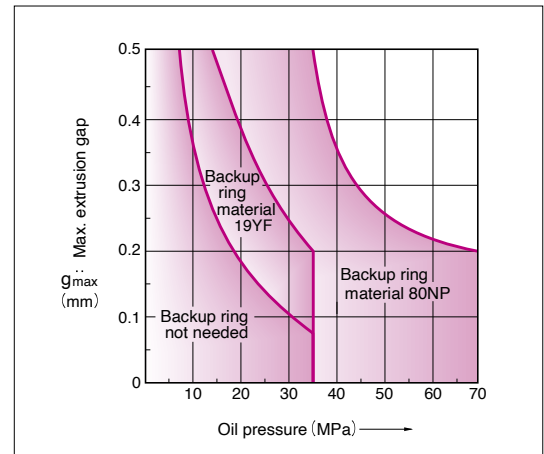

Nominal Size of Packing, and Housing dimensions						Packing Part Number	Combination Backup Ring Part Number	
d	D	h	H _A	H _B	C		BRT3 (Endless)	BRN3 (Endless)
							19YF	80NP
150	165	10	11	14	6.5	FU1360F0	GN6497V0	GN9177O1
150	170	12	13	16	6.5	FU1361F0	GN1011V0	GN9672O1
150	170	16	17	20	6.5	FU1364F0	GN1011V0	GN9672O1
150	175	16	17	20	6.5	FU1366F0	GN7014V0	GN9645O1
150	175	20	21	24	6.5	FU1368F0	GN7014V0	GN9645O1
155	180	19	20	24	6.5	FU1393F0	GN1016V0	GN9179O1
155	180	20	21	25	6.5	FU2181F0	GN1016V0	GN9179O1
160	175	10	11	15	6.5	FU1407F0	GN6499V0	GN9180O1
160	180	12	13	17	6.5	FU1409F0	GN6905V0	GN9814O0
160	180	16	17	21	6.5	FU1412F0	GN6905V0	GN9814O0
160	185	16	17	21	6.5	FU1414F0	GN1020V0	GN9181O1
160	185	19	20	24	6.5	FU2076F0	GN1020V0	GN9181O1
160	185	20	21	25	6.5	FU1416F0	GN1020V0	GN9181O1
170	185	10	11	15	6.5	FU1444F0	GN7064V0	GN9791O1
170	190	12	13	17	6.5	FU1445F0	GN6985V0	GN9816O0
170	190	16	17	21	6.5	FU1447F0	GN6985V0	GN9816O0
170	195	16	17	21	6.5	FU1449F0	GN1027V0	GN9852O0
170	195	20	21	25	6.5	FU1450F0	GN1027V0	GN9852O0
175	200	19	20	24	6.5	FU1463F0	GN1031V0	GN9186O1
175	200	20	21	25	6.5	FU2182F0	GN1031V0	GN9186O1
180	200	16	17	21	6.5	FU1486F0	GN6372V0	GN9187O1
180	205	16	17	21	6.5	FU1491F0	GN1035V0	GN9188O1
180	205	19	20	24	6.5	FU1492F0	GN1035V0	GN9188O1
180	205	20	21	25	6.5	FU1493F0	GN1035V0	GN9188O1
190	210	16	17	21	6.5	FU1518F0	GN6505V0	GN9190O1
190	215	16	17	21	6.5	FU1520F0	GN1042V0	GN9818O0
190	215	20	21	25	6.5	FU1521F0	GN1042V0	GN9818O0
199	219	11	12	16	6.5	FU1530F0	GN7279V0	GN9853O0
199	219	15	16	20	6.5	FU1531F0	GN7279V0	GN9853O0
199	224	16	17	21	6.5	FU1533F0	GN1047V0	GN9820O0
199	224	19	20	24	6.5	FU1535F0	GN1047V0	GN9820O0
200	220	16	17	21	6.5	FU1545F0	GN6276V0	GN9191O1
200	225	16	17	21	6.5	FU1548F0	GN1050V0	GN9192O1
200	225	19	20	24	6.5	FU2135F0	GN1050V0	GN9192O1
200	225	20	21	25	6.5	FU1550F0	GN1050V0	GN9192O1
210	230	16	17	21	6.5	FU1576F0	GN6352V0	GN9195O1
210	235	16	17	21	6.5	FU1578F0	GN1057V0	GN9854O0
210	235	19	20	24	6.5	FU1580F0	GN1057V0	GN9854O0
210	235	20	21	25	6.5	FU1581F0	GN1057V0	GN9854O0
220	240	16	17	21	6.5	FU1597F0	GN6508V0	GN9196O1
220	245	16	17	21	6.5	FU1598F0	GN1063V0	GN9670O0
220	245	19	20	24	6.5	FU1600F0	GN1063V0	GN9670O0
220	245	20	21	25	6.5	FU1601F0	GN1063V0	GN9670O0

E DIMENSION IDI

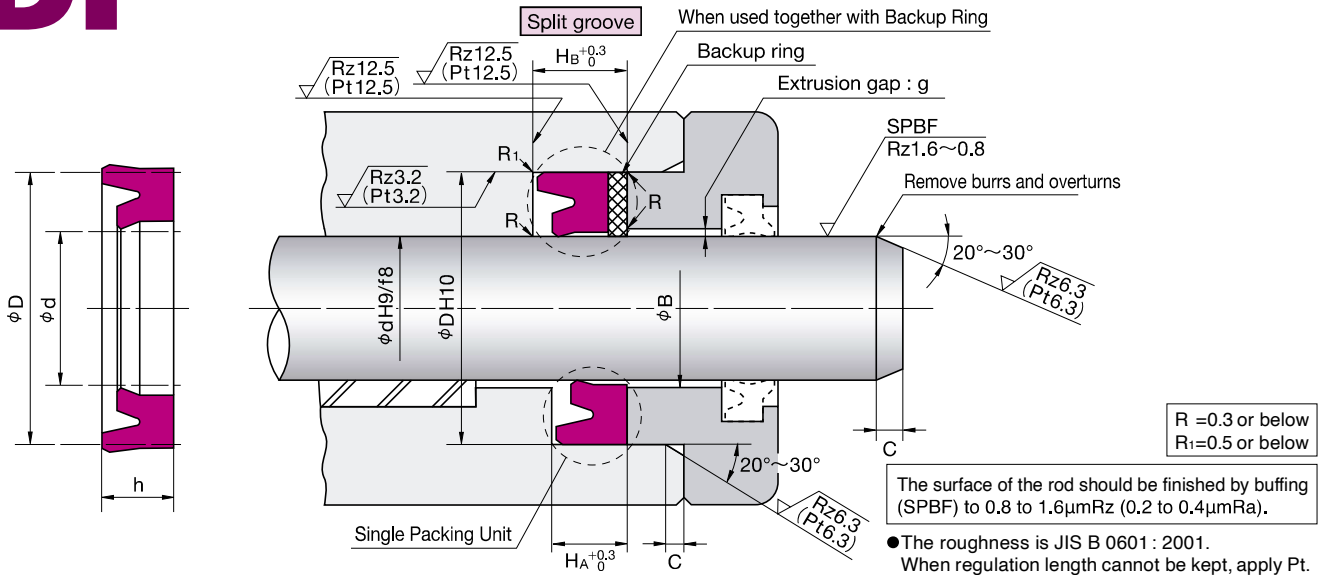

Nominal Size of Packing, and Housing dimensions						Packing Part Number	Combination Backup Ring Part Number	
d	D	h	H _A	H _B	C		BRT3 (Endless)	BRN3 (Endless)
							19YF	80NP
224	244	11	12	16	6.5	FU1608F0	GN7281V0	GN9855O0
224	244	15	16	20	6.5	FU1610F0	GN7281V0	GN9855O0
224	249	15	16	20	6.5	FU1611F0	GN7282V0	GN9856O0
224	249	18	19	23	6.5	FU1612F0	GN7282V0	GN9856O0
224	249	19	20	24	6.5	FU1613F0	GN7282V0	GN9856O0
225	245	16	17	21	6.5	FU1622F0	GN6509V0	GN9197O1
225	250	16	17	21	6.5	FU1624F0	GN1065V0	GN9045O1
225	250	19	20	24	6.5	FU1626F0	GN1065V0	GN9045O1
225	250	20	21	25	6.5	FU1627F0	GN1065V0	GN9045O1
230	250	16	17	21	6.5	FU1638F0	GN6510V0	GN9047O1
230	255	16	17	21	6.5	FU1640F0	GN1069V0	GN9857O0
230	255	19	20	24	6.5	FU1642F0	GN1069V0	GN9857O0
230	255	20	21	25	6.5	FU1643F0	GN1069V0	GN9857O0
240	260	16	17	21	6.5	FU1658F0	GN6511V0	GN9198O1
240	265	16	17	21	6.5	FU1661F0	GN1073V0	GN9858O0
240	265	19	20	24	6.5	FU1663F0	GN1073V0	GN9858O0
240	265	20	21	25	6.5	FU1664F0	GN1073V0	GN9858O0
250	270	16	17	21	6.5	FU1679F0	GN6512V0	GN9199O1
250	275	16	17	21	6.5	FU1681F0	GN1078V0	GN9200O1
250	275	19	20	24	6.5	FU1683F0	GN1078V0	GN9200O1
250	275	20	21	25	6.5	FU1684F0	GN1078V0	GN9200O1
260	285	19	20	24	8	FU1705F0	GN6514V0	GN9202O1
260	290	19	20	24	8	FU1707F0	GN1083V0	GN9431O1
265	297	24	25	29	8	FU1714F0	GN6515V0	GN9204O1
265	297	25	26	30	8	FU2183F0	GN6515V0	GN9204O1
270	295	19	20	24	8	FU1721F0	GN6516V0	GN9205O1
270	300	19	20	24	8	FU1723F0	GN1089V0	GN9206O1
270	300	24	25	29	8	FU1725F0	GN1089V0	GN9206O1
270	300	25	26	30	8	FU1726F0	GN1089V0	GN9206O1
280	305	19	20	24	8	FU1734F0	GN6518V0	GN9208O1
280	310	19	20	24	8	FU1736F0	GN1093V0	GN9859O0
280	312	24	25	29	8	FU2136F0	GN6519V0	GN9209O1
280	312	25	26	30	8	FU2184F0	GN6519V0	GN9209O1
290	315	19	20	24	8	FU1749F0	GN6520V0	GN9210O1
290	320	19	20	24	8	FU1751F0	GN1098V0	GN9860O0
300	325	19	20	24	8	FU1763F0	GN6521V0	GN9211O1
300	330	19	20	24	8	FU1765F0	GN1103V0	GN9235O1
300	332	24	25	29	8	FU2137F0	GN6522V0	GN9212O1
300	332	25	26	30	8	FU2185F0	GN6522V0	GN9212O1

E DIMENSION IDI

ISI TYPE

SPECIAL PACKINGS FOR ROD SEALS IRON RUBBER (PUR)



● Please designate NOK Part number and type & size on your order.

(Example) Order for the packing as a single piece

· Type Dimensions	ISI	18	26	5
	└─ Type Sign	└─ Nominal Size of Packing described in order of inner diameter(d), outer diameter(D), and height(h)		
· Part Number	FU0180K0			

※ When placing orders for backup rings used in combination with packing, designate the NOK part number and the model size.

· Type Dimensions	BRT2	18	26	2
	└─ Type Sign	└─ Nominal Size of Backup ring described in order of inner diameter(d), outer diameter(D), and thickness(t)*		
· Part Number	GN4778V0	*t = H _B - H _A (Housing dimensions)		

● Please check the application range on pages 14 and 15 before selecting the type.

Material	Standard : NOK U801 Heat resistant type : NOK U641
-----------------	---

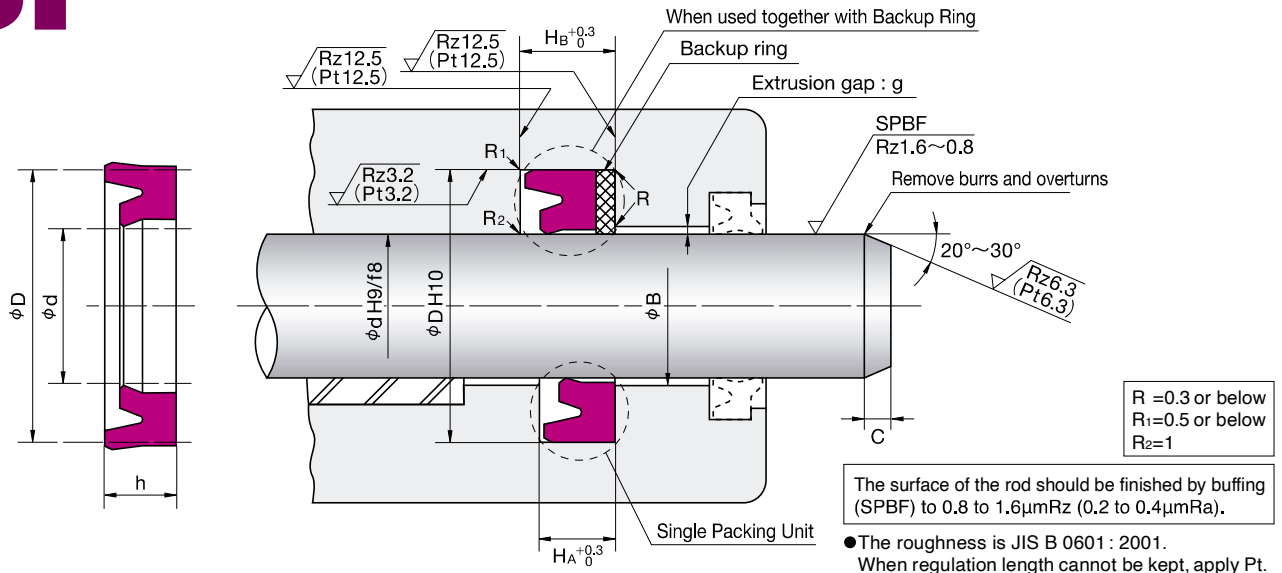

Nominal Size of Packing, and Housing dimensions						Packing Part Number		Combination Backup Ring Part Number	
d	D	h	H _A	H _B	C	Standard (U801)	Heat resistant (U641)	BRT2 (Biascut) 19YF	BRN2 (Biascut) 80NP
18	26	5	5.7	7.7	2	FU0180K0	FU0180K2	GN4778V0	GN9106O0
20	28	5	5.7	7.7	2	FU0212K0	FU0212K1	GN4780V0	GN9108O0
22.4	30	5	5.7	7.7	2	FU0260K0	FU0260K1	GN4784V0	GN9112O0
22.4	30.4	5	5.7	7.7	2	FU0261K0	FU0261K1	GN5714V0	GN9785O0
23.5	31.5	5	5.7	7.7	2	FU0267K0	FU0267K1	GN4786V0	GN9114O0
25	33	5	5.7	7.7	2.5	FU0276K0	FU0276K2	GN5019V1	GN9786O0
25	35	5	5.7	7.7	2.5	FU0278K0	FU0278K2	GN4787V0	GN9115O0
28	35.5	5	5.7	8.7	2.5	FU0320K0	FU0320K1	GN4791V0	GN9119O0
28	36	5	5.7	8.7	2.5	FU0321K0	FU0321K1	GN5715V0	GN9787O0
30	40	6	7	10	2.5	FU0357K0	FU0357K3	GN4794V0	GN9122O0
31.5	41.5	6	7	10	2.5	FU0382K0	FU0382K1	GN4796V0	GN9124O0
35	45	6	7	10	2.5	FU0424K0	FU0424K7	GN4799V0	GN9127O0
35.5	45	6	7	10	2.5	FU0451K0	FU0451K1	GN4801V0	GN9129O0
35.5	45.5	6	7	10	2.5	FU0452K0	FU0452K1	GN5716V0	GN9788O0
36	46	6	7	10	2.5	FU2921K1	FU2921K0	GN5733V0	GN3033O0
40	50	6	7	10	2.5	FU0497K0	FU0497K5	GN4050V0	GN9131O0
45	55	6	7	10	2.5	FU0567K0	FU0567K6	GN4804V0	GN9133O0
45	56	7	8	11	2.5	FU0572K0	FU0572K1	GN4805V0	GN9134O0
50	60	6	7	10	2.5	FU0619K0	FU0619K3	GN4335V0	GN9138O0
53	63	6	7	10	2.5	FU0679K0	FU0679K2	GN4693V0	GN9140O0
55	65	6	7	10	2.5	FU0694K0	FU0694K2	GN4810V0	GN9141O0
56	66	6	7	10	2.5	FU0722K0	FU0722K1	GN4766V0	GN9143O0
60	70	6	7	10	2.5	FU0746K0	FU0746K5	GN4676V0	GN9144O0
60	71	7	8	11	2.5	FU0750K0	FU0750K1	GN4812V0	GN9145O0
63	73	6	7	10	2.5	FU0786K0	FU0786K3	GN4814V0	GN9147O0
65	75	6	7	10	2.5	FU0809K0	FU0809K1	GN4816V0	GN9149O0
67	77	6	7	10	2.5	FU0828K0	FU0828K1	GN4697V0	GN9150O0
70	80	6	7	10	2.5	FU0849K0	FU0849K5	GN4651V0	GN9092O0
71	81	6	7	10	2.5	FU0880K0	FU0880K1	GN4819V0	GN9153O0
75	85	6	7	10	2.5	FU0901K0	FU0901K1	GN4692V0	GN9241O0
80	90	6	7	10	2.5	FU0939K0	FU0939K1	GN4820V0	GN9155O0
85	100	9	10	13	4	FU0984K0	FU0984K2	GN4687V0	GN9091O0
90	105	9	10	13	4	FU1024K0	FU1024K3	GN4698V0	GN9158O0
95	110	9	10	13	4	FU1051K0	FU1051K2	GN4822V0	GN9160O0
98	112	8.5	9.5	12.5	4	FU1067K0	FU1067K1	GN4824V0	GN9162O0
100	115	9	10	13	4	FU1082K0	FU1082K1	GN4512V0	GN9163O0
105	120	9	10	13	4	FU1125K0	FU1125K1	GN5198V0	GN9589O0
106	120	8.5	9.5	12.5	4	FU1135K0	FU1135K1	GN4826V0	GN9166O0
106	121	9	10	13	4	FU1136K0	FU1136K1	GN5717V0	GN9789O0
110	125	9	10	13	4	FU1157K0	FU1157K2	GN4480V0	GN9430O0
112	125	9	10	13	4	FU1179K0	FU1179K1	GN4827V0	GN9167O0
115	130	9	10	13	4	FU1195K1	FU1195K2	GN4593V0	GN9274O0

HOW TO DETERMINE B DIMENSION

■ When using backup ring

Please determine B dimension according to the table below. If you require smaller B dimension because of the cylinder configuration, please consult NOK.

Maximum Service Pressure	14MPa	21MPa	35MPa
Material of Backup ring	19YF		
B Dimension	$B \leq \phi d + 1.0$	$B \leq \phi d + 0.5$	$B \leq \phi d + 0.2$

Maximum Service Pressure	35MPa	42MPa
Material of Backup ring	80NP	
B Dimension	$B \leq \phi d + 0.8$	$B \leq \phi d + 0.4$

■ When not using backup ring

To determine B dimension, please refer to the graph in the right for the maximum extrusion gap (one side) considering the eccentricity of operating condition of the piston.

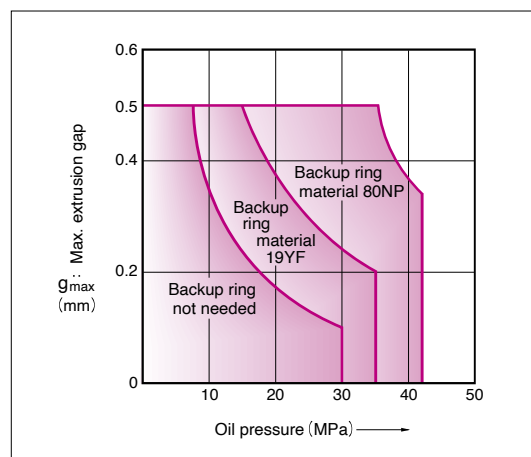

Nominal Size of Packing, and Housing dimensions						Packing Part Number		Combination Backup Ring Part Number	
d	D	h	H _A	H _B	C	Standard (U801)	Heat resistant (U641)	BRT2 (Biascut) 19YF	BRN2 (Biascut) 80NP
118	133	9	10	13	4	FU1205K0	FU1205K1	GN5718V0	GN9790O0
120	135	9	10	13	4	FU1220K0	FU1220K1	GN5036V0	GN9679O0
125	140	9	10	13	4	FU1252K0	FU1252K1	GN4481V0	GN9170O0
130	145	9	10	13	4	FU1280K0	FU1280K1	GN4628V1	GN9742O1
136	150	8.5	9.5	12.5	4	FU1306K0	FU1306K1	GN4830V0	GN9173O0
140	155	9	10	13	4	FU1323K0	FU1323K2	GN4526V0	GN9410O0
145	160	9	10	13	4	FU1343K0	FU1343K1	GN4551V0	GN9175O0
150	165	9	10	13	4	FU1359K0	FU1359K1	GN4833V0	GN9177O0
155	170	9	10	14	4	FU1388K0	FU1388K2	GN4834V0	GN9178O0
160	175	9	10	14	4	FU1406K0	FU1406K1	GN4835V0	GN9180O0
165	180	9	10	14	4	FU1429K0	FU1429K1	GN4836V0	GN9182O0
170	185	9	10	14	4	FU1443K0	FU1443K2	GN5464V0	GN9791O0
175	190	9	10	14	4	FU1459K0	FU1459K1	GN4839V0	GN9185O0
180	200	12	13	17	5	FU1483K0	FU1483K1	GN4470V0	GN9187O0
190	210	12	13	17	5	FU1516K0	FU1516K1	GN4841V0	GN9190O0
200	220	12	13	17	5	FU1543K0	FU1543K1	GN4385V0	GN9191O0
204	224	12	13	17	5	FU1563K0	FU1563K1	GN4842V0	GN9193O0
210	230	12	13	17	5	FU1575K0	FU1575K1	GN4627V0	GN9195O0
220	240	12	13	17	5	FU1596K0	FU1596K1	GN4444V0	GN9196O0
225	245	12	13	17	5	FU1621K0	FU1621K1	GN4844V0	GN9197O0
230	250	12	13	17	5	FU1637K0	FU1637K1	GN4635V0	GN9047O0
240	260	12	13	17	5	FU1657K0	FU1657K1	GN4845V0	GN9198O0
250	270	12	13	17	5	FU1678K0	FU1678K1	GN4459V0	GN9199O0
260	285	16	17	21	6.5	FU1704K0	FU1704K1	GN4847V0	GN9202O0
270	295	16	17	21	6.5	FU1720K0	FU1720K1	GN4850V0	GN9205O0
280	305	16	17	21	6.5	FU1733K0	FU1733K1	GN4410V0	GN9208O0
290	315	16	17	21	6.5	FU1748K0	FU1748K1	GN4854V0	GN9210O0
300	325	16	17	21	6.5	FU1762K0	FU1762K1	GN4855V0	GN9211O0

IUIS TYPE

SPECIAL PACKINGS FOR ROD SEALS IRON RUBBER (PUR)



● Please designate NOK Part number and type & size on your order.

(Example) Order for the packing as a single piece

• Type Dimensions	<u>IUIS</u>	<u>18</u>	<u>26</u>	<u>5</u>	
	└─ Type Sign	└─ Nominal Size of Packing described in order of inner diameter(d), outer diameter(D), and height(h)			
• Part Number	FU0180R0				

※ When placing orders for backup rings used in combination with packing, designate the NOK part number and the model size.

• Type Dimensions	<u>BRT2</u>	<u>18</u>	<u>26</u>	<u>2</u>	
	└─ Type Sign	└─ Nominal Size of Backup ring described in order of inner diameter(d), outer diameter(D), and thickness(t)*			
• Part Number	GN4778V0				*t = H _B - H _A (Housing dimensions)

● Please check the application range on pages 16 and 17 before selecting the type.

Material	Standard : NOK U801 Heat resistant type : NOK U641
-----------------	---

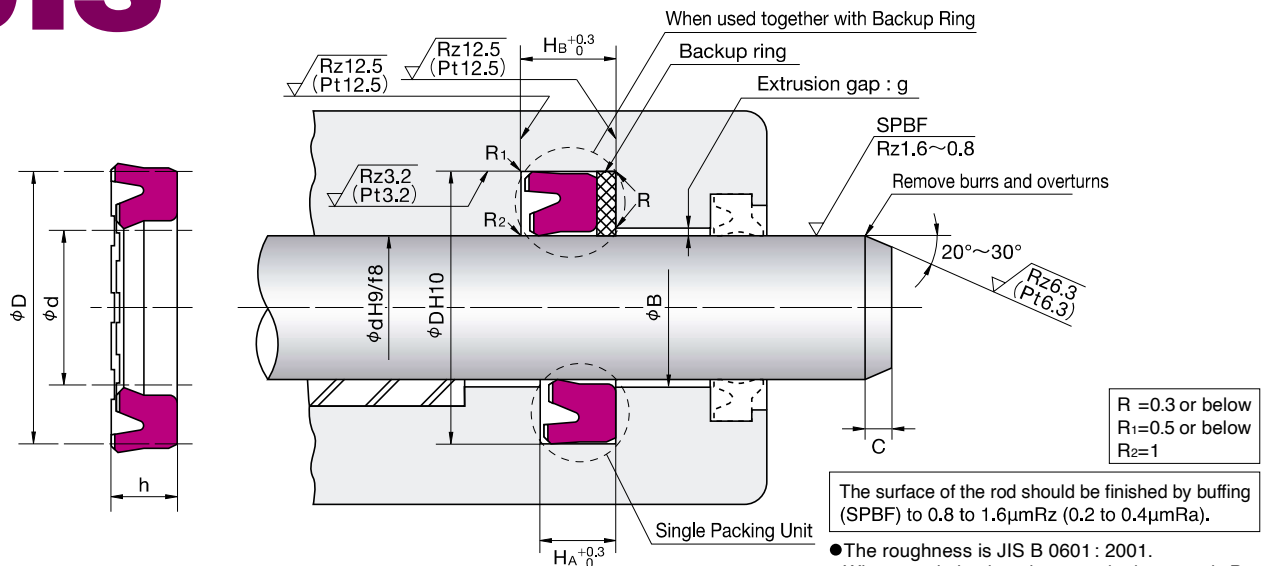

HOW TO DETERMINE B DIMENSION

■ When using backup ring

Please determine B dimension according to the table below. If you require smaller B dimension because of the cylinder configuration, please consult NOK.

Maximum Service Pressure	14MPa	21MPa	35MPa
Material of Backup ring	19YF		
B Dimension	$B \leq \phi d + 1.0$	$B \leq \phi d + 0.5$	$B \leq \phi d + 0.2$
Maximum Service Pressure	35MPa	42MPa	
Material of Backup ring	80NP		
B Dimension	$B \leq \phi d + 0.8$	$B \leq \phi d + 0.4$	

■ When not using backup ring

To determine B dimension, please refer to the graph in the right for the maximum extrusion gap (one side) considering the eccentricity of operating condition of the piston.

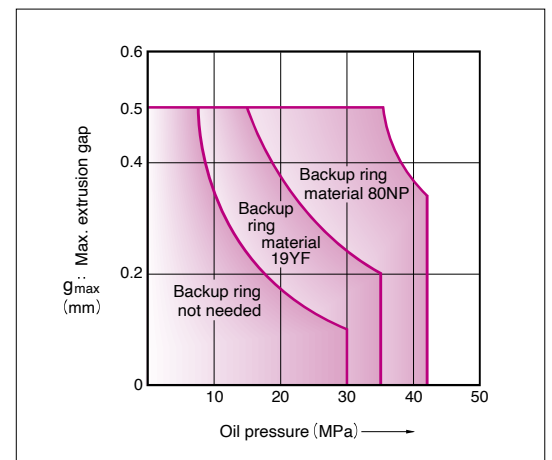

Nominal Size of Packing, and Housing dimensions						Packing Part Number		Combination Backup Ring Part Number	
								BRT2 (Biacsut)	BRN2 (Biacsut)
d	D	h	H _A	H _B	C	Standard (U801)	Heat resistant (U641)	19YF	80NP
18	26	5	5.7	7.7	2	FU0180R0	FU0180R1	GN4778V0	GN910600
22.4	30	5	5.7	7.7	2	FU0260R0	FU0260R1	GN4784V0	GN911200
28	35.5	5	5.7	8.7	2.5	FU0320R0	FU0320R1	GN4791V0	GN911900
30	40	6	7	10	2.5	FU0357R0	FU0357R1	GN4794V0	GN912200
35	45	6	7	10	2.5	FU0424R1	FU0424R2	GN4799V0	GN912700
35.5	45	6	7	10	2.5	FU0451R0	FU0451R1	GN4801V0	GN912900
40	50	6	7	10	2.5	FU0497R0	FU0497R1	GN4050V0	GN913100
45	55	6	7	10	2.5	FU0567R1	FU0567R2	GN4804V0	GN913300
45	56	7	8	11	2.5	FU0572R0	FU0572R1	GN4805V0	GN913400
50	60	6	7	10	2.5	FU0619R0	FU0619R1	GN4335V0	GN913800
55	65	6	7	10	2.5	FU0694R1	FU0694R2	GN4810V0	GN914100
56	66	6	7	10	2.5	FU0722R0	FU0722R1	GN4766V0	GN914300
70	80	6	7	10	2.5	FU0849R1	FU0849R0	GN4651V0	GN909200
80	90	6	7	10	2.5	FU0939R0	FU0939R1	GN4820V0	GN915500
85	100	9	10	13	4	FU0984R0	FU0984R1	GN4687V0	GN909100
90	105	9	10	13	4	FU1024R0	FU1024R1	GN4698V0	GN915800
95	110	9	10	13	4	FU1051R0	FU1051R1	GN4822V0	GN916000
100	115	9	10	13	4	FU1082R0	FU1082R1	GN4512V0	GN916300
125	140	9	10	13	4	FU1252R0	FU1252R1	GN4481V0	GN917000
130	145	9	10	13	4	FU1280R1	FU1280R0	GN4628V1	GN974201
140	155	9	10	13	4	FU1323R0	FU1323R1	GN4526V0	GN941000
160	175	9	10	14	4	FU1406R0	FU1406R1	GN4835V0	GN918000
170	185	9	10	14	4	FU1443R2	FU1443R0	GN5464V0	GN979100
175	190	9	10	14	4	FU1459R1	FU1459R0	GN4839V0	GN918500
180	200	12	13	17	5	FU1483R0	FU1483R1	GN4470V0	GN918700

IUH TYPE

SPECIAL PACKINGS FOR ROD SEALS

NITRILE RUBBER (NBR) +
HYDROGENATED NITRILE RUBBER (H-NBR)



● Please designate NOK Part number and type & size on your order.

(Example) Order for the packing as a single piece

· Type Dimensions	IUH	14	22	5
	└─ Type Sign	└─ Nominal Size of Packing described in order of inner diameter(d), outer diameter(D), and height(h)		
· Part Number	CU2692N1			

※ When placing orders for backup rings used in combination with packing, designate the NOK part number and the model size.

· Type Dimensions	BRT2	14	22	2
	└─ Type Sign	└─ Nominal Size of Backup ring described in order of inner diameter(d), outer diameter(D), and thickness(t)*		
· Part Number	GN5719V0			

*t = H_B - H_A (Housing dimensions)

● Please check the application range on pages 16 and 17 before selecting the type.

Material	Standard : NOK A505 Cold resistant type : NOK A567 Heat resistant type : NOK G928
-----------------	---

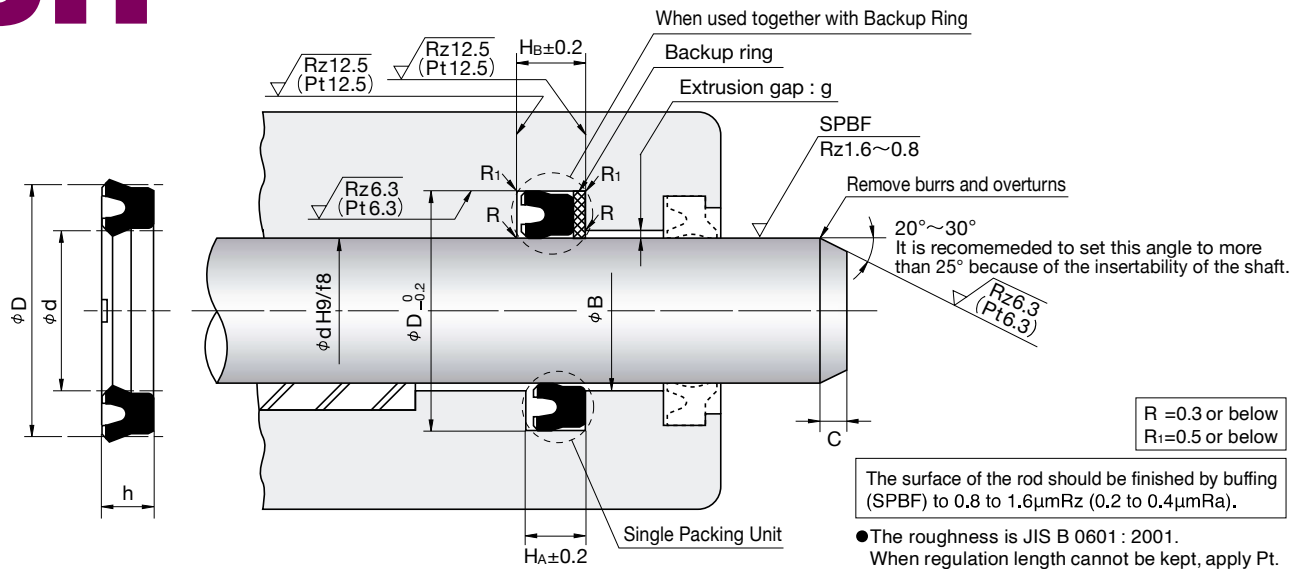

Nominal Size of Packing, and Housing dimensions						Packing Part Number			Combination Backup Ring Part Number
d	D	h	H _A	H _B	C	Standard (A505)	Cold resistant (A567)	Heat resistant (G928)	BRT2 (Biascut)
14	22	5	5.7	7.7	2.5	● CU2692N1			GN5719V0
16	24	5	5.7	7.7	2.5	● CU2548N0			GN5720V0
18	26	5	5.7	7.7	2.5	CU0180N2			GN4778V0
20	28	5	5.7	7.7	2.5	CU0212N3	CU0212N5		GN4780V0
22.4	30	5	5.7	7.7	2.5	CU3488N0			GN4784V0
25	33	5	5.7	7.7	2.5	CU0276N3	CU0276N5		GN5019V1
28	35.5	5	5.7	8.7	2.5	CU0320N0			GN4791V0
30	40	6	7	10	3	CU0357N3	CU0357N5		GN4794V0
35	45	6	7	10	3	CU0424N3	CU0424N5		GN4799V0
35.5	45	6	7	10	3	CU0451N2			GN4801V0
36	46	6	7	10	3	CU3040N0			GN5733V0
40	50	6	7	10	3	CU0497N4	CU0497N6		GN4050V0
45	55	6	7	10	3	CU0567N4	CU0567N6		GN4804V0
45	56	7	8	11	3	CU0572N1			GN4805V0
50	60	6	7	10	3	CU0619N3	CU0619N5	CU0619N6	GN4335V0
53	63	6	7	10	3			CU0679N0	GN4693V0
55	65	6	7	10	3	CU0694N3	CU0694N5	CU0694N6	GN4810V0
56	66	6	7	10	3	CU0722N2			GN4766V0
60	70	6	7	10	3	CU0746N3	CU0746N6	CU0746N8	GN4676V0
63	73	6	7	10	3	CU0786N2			GN4814V0
65	75	6	7	10	3	CU0809N2	CU0809N4	CU0809N6	GN4816V0
65	80	9	10	13	4			CU3615N0	GN4549V0
67	77	6	7	10	3	CU0828N0			GN4697V0
70	80	6	7	10	4	CU0849N0		CU0849N2	GN4651V0
70	85	9	10	13	4	CU0857N2	CU0857N3	CU0857N4	GN4876V0
71	80	6	7	10	4	CU0879N0			GN4818V0
75	85	6	7	10	4	CU0901N4	CU0901N6	CU0901N8	GN4692V0
75	90	9	10	13	4	CU3090N2		CU3090N4	GN4971V0
80	90	6	7	10	4	CU0939N3	CU0939N4	CU0939N6	GN4820V0
80	95	9	10	13	4	CU3091N2		CU3091N4	GN5023V0
85	100	9	10	13	4	CU0984N1		CU0984N3	GN4687V0
85	105	12	13	16	5.5			CU0989N0	GN4821V0
90	105	9	10	13	4	CU1024N3	CU1024N5	CU1024N6	GN4698V0
90	110	12	13	16	5.5			CU1030N0	GN4109V0
95	110	9	10	13	4	CU1051N2	CU1051N5	CU1051N7	GN4822V0
95	115	12	13	16	5.5			CU1056N0	GN4823V0
100	115	9	10	13	4	CU1082N3	CU1082N5	CU1082N7	GN4512V0
100	120	12	13	16	5.5	CU1089N1		CU1089N2	GN4119V0
105	120	9	10	13	4	CU1125N1	CU1125N2	CU1125N4	GN5198V0
105	125	12	13	16	5.5	CU1128N0			GN4825V0
105	125	15	16	19	5.5			CU1129N0	GN4825V0

Remark 1) Since the mold is utilized, the part number and the product's engraved mark may be different.
 Remark 2) When using the packing with ●, provide separate grooves.

HOW TO DETERMINE B DIMENSION

■ When using backup ring

Please determine B dimension according to the table below. If you require smaller B dimension because of the cylinder configuration, please consult NOK.

Maximum Service Pressure	14MPa	21MPa
Material of Backup ring	19YF	
B Dimension	$B \leq \phi d + 1.0$	$B \leq \phi d + 0.5$

■ When not using backup ring

To determine B dimension, please refer to the graph in the right for the maximum extrusion gap (one side) considering the eccentricity of operating condition of the piston.

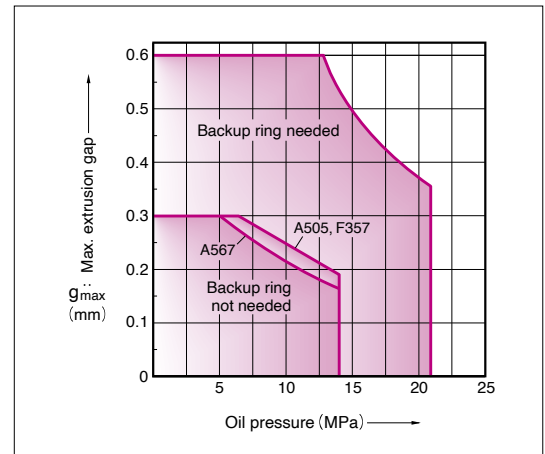

Nominal Size of Packing, and Housing dimensions						Packing Part Number			Combination Backup Ring Part Number
d	D	h	H _A	H _B	C	Standard (A505)	Cold resistant (A567)	Heat resistant (G928)	BRT2 (Biascut) 19YF
110	125	9	10	13	4	CU1157N3	CU1157N5	CU1157N6	GN4480V0
110	130	15	16	19	5.5			CU1165N0	GN4280V1
112	125	8.5	9.5	12.5	4	CU1178N0			GN4827V0
115	130	9	10	13	4	CU1195N0	CU1195N1	CU1195N2	GN4593V0
115	135	16	17	20	5.5			CU1184N0	GN4574V0
120	135	9	10	13	4	CU1220N3	CU1220N2	CU1220N4	GN5036V0
120	140	15	16	19	5.5			CU1224N0	GN4132V0
125	140	9	10	13	4	CU1252N3	CU1252N5	CU01252-N7A	GN4481V0
130	145	9	10	13	4	CU1280N0	CU1280N1	CU1280N2	GN4628V1
130	150	16	17	20	5.5			CU2771N0	GN4142V0
135	150	9	10	13	4	CU2264N2	CU2264N0		GN5025V0
140	155	9	10	13	4	CU1323N2	CU1323N3	CU01323-N5A	GN4526V0
145	160	9	10	13	4	CU1343N0			GN4551V0
150	165	9	10	13	4	CU1359N2	CU1359N4	CU01359-N5A	GN4833V0
160	175	9	10	14	4	CU1406N1			GN4835V0
170	190	12	13	17	5.5	CU3494N1	CU3494N0	CU3494N2	GN4529V0
180	200	12	13	17	5.5	CU1483N2	CU1483N3		GN4470V0
190	215	16	17	21	7	CU3523N0	CU3523N2		GN4577V0
200	225	16	17	21	7	CU1548N1			GN4560V0
210	235	16	17	21	7	CU3640N0			GN5758V0
220	245	16	17	21	7	CU3630N0		CU3630N1	GN5754V0
240	265	19	20	24	7	CU3335N1			GN4428V1

Remark) The Part number and the one stamped on the product might be different in case of heat resistant type.

UNI TYPE

**SPECIAL PACKINGS
FOR ROD SEALS
IRON RUBBER (PUR) +
SILICON RUBBER (VMQ)**



E-21
DIMENSION

● Please designate NOK Part number and type & size on your order.

(Example) Order for the packing as a single piece

• Type Dimensions	<u>UNI</u>	<u>40</u>	<u>50</u>	<u>7</u>
	└─ Type Sign	└─ Nominal Size of Packing described in order of inner diameter(d), outer diameter(D), and height(h)		
• Part Number	FU2002M1			

※ When placing orders for backup rings used in combination with packing, designate the NOK part number and the model size.

• Type Dimensions	<u>BRT3</u>	<u>40</u>	<u>50</u>	<u>3</u>
	└─ Type Sign	└─ Nominal Size of Backup ring described in order of inner diameter(d), outer diameter(D), and thickness(t)*		
• Part Number	GN6465V0			

*t = H_B - H_A (Housing dimensions)

● Please check the application range on pages 16 and 17 before selecting the type.

Material	NOK U801 + NOK S813
-----------------	---------------------

UNI TYPE SPECIAL PACKINGS FOR ROD SEALS

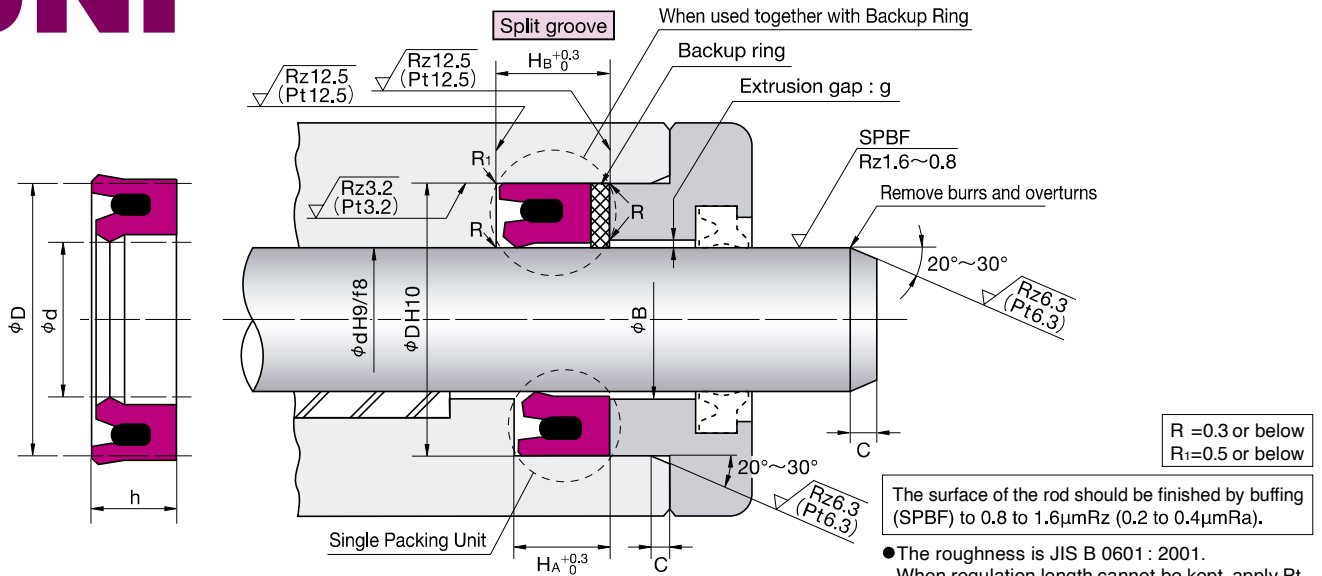

R = 0.3 or below
R₁ = 0.5 or below

The surface of the rod should be finished by buffing (SPBF) to 0.8 to 1.6 μm Rz (0.2 to 0.4 μm Ra).

● The roughness is JIS B 0601 : 2001.
When regulation length cannot be kept, apply Pt.

HOW TO DETERMINE B DIMENSION

When using backup ring

Please determine B dimension according to the table below. If you require smaller B dimension because of the cylinder configuration, please consult NOK.

Maximum Service Pressure	14MPa	21MPa	35MPa
Material of Backup ring	19YF		
B Dimension	$B \leq \phi d + 1.0$	$B \leq \phi d + 0.5$	$B \leq \phi d + 0.2$

Maximum Service Pressure	35MPa	42MPa
Material of Backup ring	80NP	
B Dimension	$B \leq \phi d + 0.8$	$B \leq \phi d + 0.4$

When not using backup ring

To determine B dimension, please refer to the graph in the right for the maximum extrusion gap (one side) considering the eccentricity of operating condition of the piston.

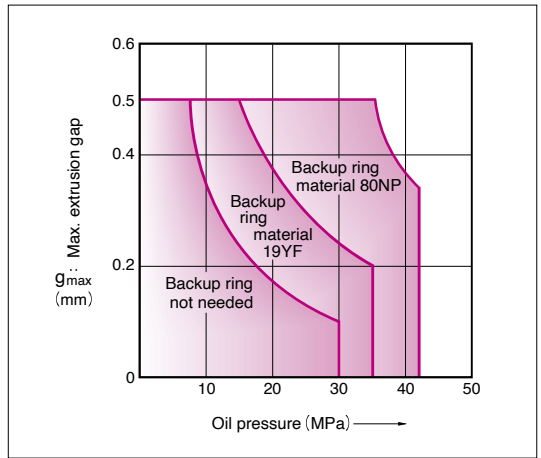

Nominal Size of Packing, and Housing dimensions						Packing Part Number	Combination Backup Ring Part Number	
d	D	h	H _A	H _B	C		BRT3 (Endless) 19YF	BRN3 (Endless) 80NP
40	50	7	8	11	4	FU2002M1	GN6465V0	GN9131O1
45	55	7	8	11	4	FU0568M1	GN6467V0	GN9133O1
50	63	10	11	14	4	FU1925M1	GN7285V0	GN9861O0
55	68	10	11	14	4	FU1995M1	GN7286V0	GN9862O0
60	73	10	11	14	4	FU2097M1	GN7287V0	GN9863O0
65	78	10	11	14	5	FU2074M1	GN6798V0	GN9864O0
70	83	10	11	14	5	FU2088M1	GN6556V0	GN9865O0
75	88	10	11	14	5	FU2227M1	GN6558V0	GN9866O0
80	93	10	11	14	5	FU2107M1	GN6557V0	GN9867O0
85	105	15	16	19	5	FU0990M1	GN0932V0	GN9157O1
90	110	15	16	19	5	FU1031M1	GN0939V0	GN9159O1
100	120	15	16	19	5	FU1091M1	GN0952V0	GN9164O1
110	130	15	16	19	5	FU1165M1	GN6790V0	GN9694O0
120	140	15	16	19	5	FU1224M1	GN0982V0	GN9169O1
130	150	16	17	20	5	FU1285M1	GN6925V0	GN9335O1
140	165	19	20	23	6.5	FU1332M1	GN6494V0	GN9174O1

SPNO TYPE SPECIAL PACKINGS FOR ROD SEALS

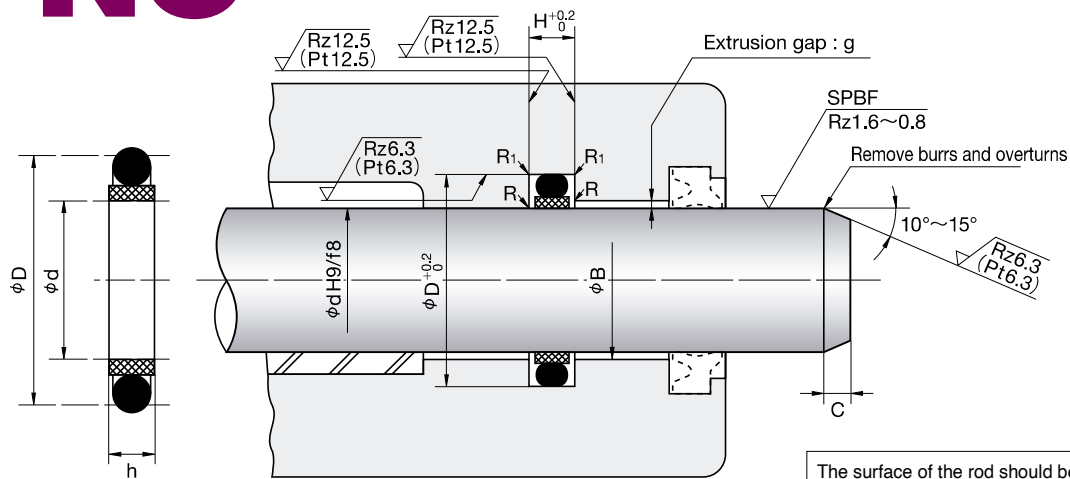

$R = 0.3$ or below
 $R_1 = 0.5$ or below
 The surface of the rod should be finished by buffing (SPBF) to 0.8 to 1.6μmRz (0.2 to 0.4μmRa).
 ● The roughness is JIS B 0601 : 2001.
 When regulation length cannot be kept, apply Pt.

Nominal Number	Nominal Size of Packing, and Housing dimensions					NOK Part Number
	d	D	h	H	C	
SPNO 12	12	18	3	3.2	2	● GS2800V0
14	14	20	3	3.2	2	● GS2801V0
16	16	22	3	3.2	2	● GS2802V0
18	18	24	3	3.2	2	● GS2803V0
20	20	26	3	3.2	2	● GS2804V0
22	22	31	3.8	4	3.5	● GS2805V0
25	25	34	3.8	4	3.5	● GS2806V0
28	28	37	3.8	4	3.5	● GS2807V0
30	30	39	3.8	4	3.5	● GS2808V0
32	32	41	3.8	4	3.5	● GS2809V0
36	36	45	3.8	4	3.5	● GS2810V0
40	40	49	3.8	4	3.5	● GS2811V0
45	45	54	3.8	4	3.5	● GS2812V0
50	50	65	6.3	6.5	4	● GS2813V0
56	56	71	6.3	6.5	4	GS2814V0
60	60	75	6.3	6.5	4	GS2815V0
63	63	78	6.3	6.5	4	GS2816V0
70	70	85	6.3	6.5	5	GS2817V0
75	75	90	6.3	6.5	5	GS2818V0
80	80	95	6.3	6.5	5	GS2819V0
85	85	100	6.3	6.5	5	GS2820V0
90	90	105	6.3	6.5	5	GS2821V0
95	95	110	6.3	6.5	5	GS2822V0
100	100	115	6.3	6.5	5	GS2823V0
105	105	120	6.3	6.5	5	GS2824V0
110	110	125	6.3	6.5	5	GS2825V0
115	115	130	6.3	6.5	6.5	GS2826V0
120	120	135	6.3	6.5	6.5	GS2827V0
125	125	140	6.3	6.5	6.5	GS2828V0
130	130	145	6.3	6.5	6.5	GS2829V0
135	135	150	6.3	6.5	6.5	GS2830V0
140	140	155	6.3	6.5	6.5	GS2831V0
145	145	160	6.3	6.5	6.5	GS2832V0

Remark) When using the packing with ●, provide separate grooves.

HOW TO DETERMINE B DIMENSION

To determine B dimension, please refer to the graph in the right for the maximum extrusion gap (one side) considering the eccentricity of operating condition of the piston.

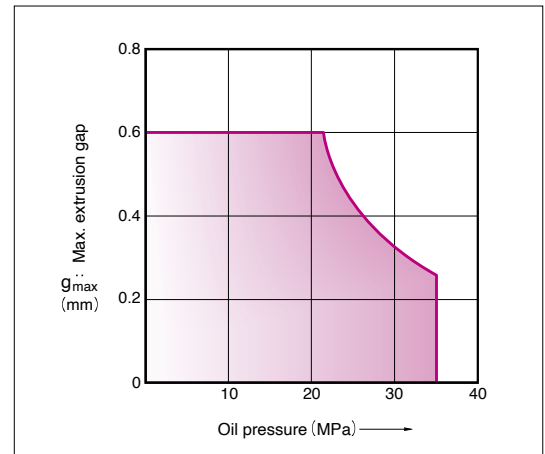

Nominal Number	Nominal Size of Packing, and Housing dimensions					NOK Part Number
	d	D	h	H	C	
SPNO 150	150	170	9.8	10	6.5	GS2833V0
160	160	180	9.8	10	6.5	GS2834V0
170	170	190	9.8	10	6.5	GS2835V0
180	180	200	9.8	10	6.5	GS2836V0
190	190	210	9.8	10	6.5	GS2837V0
200	200	220	9.8	10	6.5	GS2838V0
210	210	230	9.8	10	6.5	GS2839V0
220	220	240	9.8	10	6.5	GS2840V0
224	224	244	9.8	10	6.5	GS2841V0
230	230	250	9.8	10	6.5	GS2842V0
240	240	260	9.8	10	6.5	GS2843V0
250	250	270	9.8	10	6.5	GS2844V0
260	260	280	9.8	10	7.5	GS2845V0
270	270	290	9.8	10	7.5	GS2846V0
280	280	300	9.8	10	7.5	GS2847V0
290	290	310	9.8	10	7.5	GS2848V0
300	300	320	9.8	10	7.5	GS2849V0
310	310	330	9.8	10	7.5	GS2850V0
320	320	340	9.8	10	7.5	GS2851V0
330	330	350	9.8	10	7.5	GS2852V0
340	340	360	9.8	10	7.5	GS2853V0
350	350	370	9.8	10	7.5	GS2854V0
360	360	380	9.8	10	7.5	GS2855V0
370	370	390	9.8	10	7.5	GS2856V0
380	380	400	9.8	10	7.5	GS2857V0

SPN TYPE

SPECIAL PACKINGS FOR ROD SEALS

RAREFLON (PTFE) +
NITRILE RUBBER (NBR)



E
DIMENSION
SPN

- Please designate NOK Part number and type & size on your order.

(Example) · Type Dimensions

SPN 18 27 4.3

Type Sign

Nominal Size of Packing
described in order of
inner diameter(d), outer diameter(D), and height(h)

· Part Number

GS2301V0

- Please check the application range on pages 16 and 17 before selecting the type.

Material	NOK 19YF + NOK A980
-----------------	---------------------

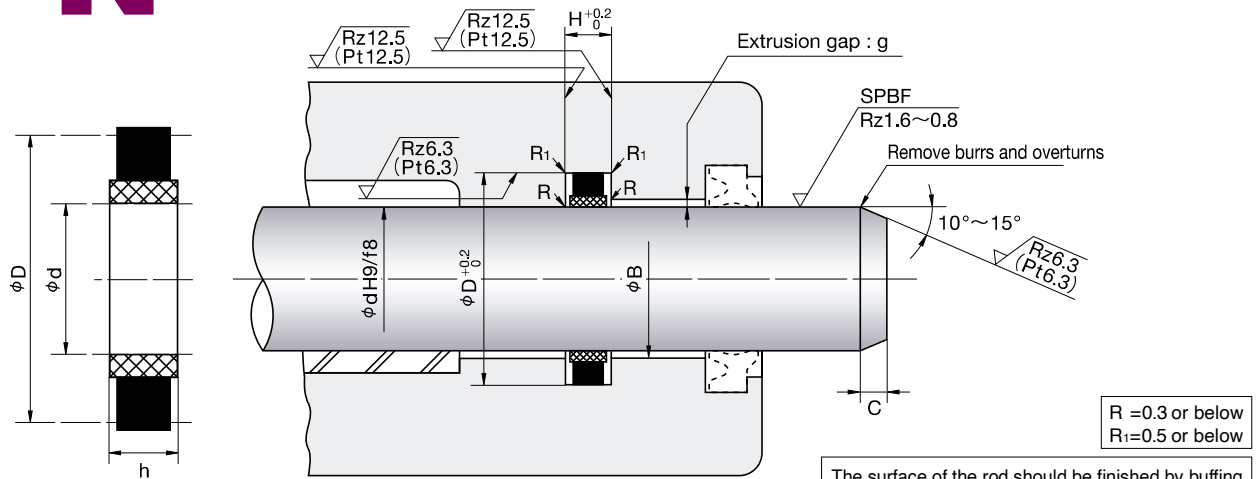

The surface of the rod should be finished by buffing (SPBF) to 0.8 to 1.6 μ mRz (0.2 to 0.4 μ mRa).

- The roughness is JIS B 0601 : 2001. When regulation length cannot be kept, apply Pt.

HOW TO DETERMINE B DIMENSION

To determine B dimension, please refer to the graph in the right for the maximum extrusion gap (one side) considering the eccentricity of operating condition of the piston.

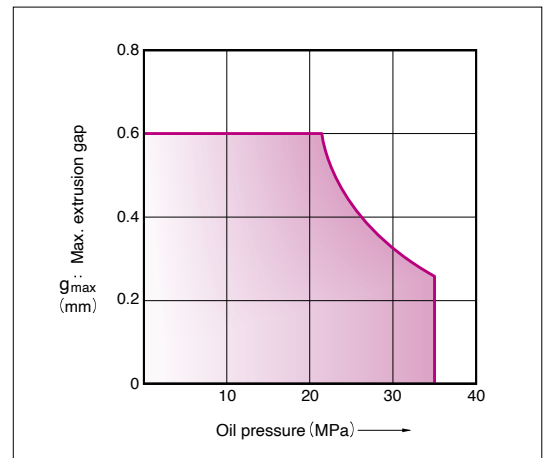

Nominal Number	Nominal Size of Packing, and Housing dimensions					NOK Part Number
	d	D	h	H	C	
SPN 18	18	27	4.3	4.5	3.5	● GS2301V0
20	20	29	4.3	4.5	3.5	● GS2302V0
22	22	31	4.3	4.5	3.5	● GS2303V0
27	27	36	4.3	4.5	4	● GS2304V0
31.5	31.5	40.5	4.3	4.5	4	● GS2305V0
47	47	60	7.3	7.5	4	● GS2306V0
53	53	66	7.3	7.5	4	GS2307V0
60	60	73	7.3	7.5	4	GS2308V0
65	65	78	7.3	7.5	5	GS2309V0
70	70	83	7.3	7.5	5	GS2310V0
75	75	88	7.3	7.5	5	GS2311V0
80	80	93	7.3	7.5	5	GS2312V0
90	90	103.4	7.3	7.5	5	GS2313V0
100	100	113.4	7.3	7.5	5	GS2314V0
105	105	118.4	7.3	7.5	5	GS2315V0
110	110	123.4	7.3	7.5	5	GS2316V0
120	120	133.4	7.3	7.5	5	GS2317V0
130	130	143.4	7.3	7.5	6.5	GS2318V0
140	140	153.4	7.3	7.5	6.5	GS2319V0

Remark) When using the packing with ●, provide separate grooves.

SPNS TYPE SPECIAL PACKINGS FOR ROD SEALS

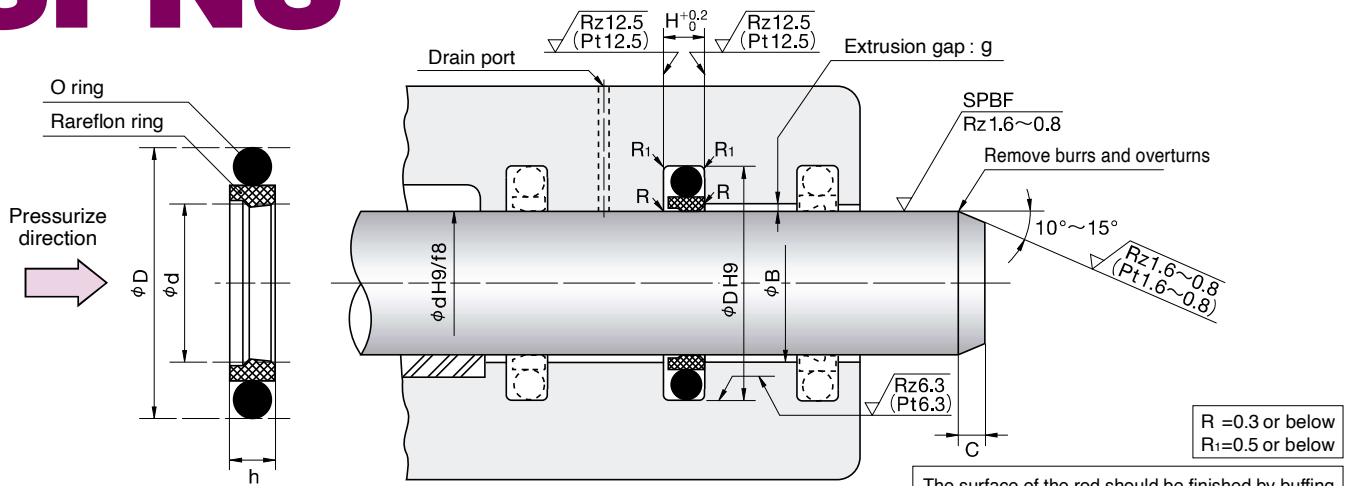

The surface of the rod should be finished by buffing (SPBF) to 0.8 to 1.6µmRz (0.2 to 0.4µmRa).

● The roughness is JIS B 0601 : 2001.
When regulation length cannot be kept, apply Pt.

Nominal Number	Nominal Size of Packing, and Housing dimensions					NOK Part Number
	d	D	h	H	C	
SPNS 4	4	8.9	2	2.2	3.5	● GS5000V5
5	5	9.9	2	2.2	3.5	● GS5001V5
6	6	10.9	2	2.2	3.5	● GS5002V5
7	7	11.9	2	2.2	3.5	● GS5003V5
8S	8	12.9	2	2.2	3.5	● GS5004V5
8	8	15.3	2.9	3.2	3.5	● GS5005V5
10S	10	14.9	2	2.2	3.5	● GS5006V5
10	10	17.3	2.9	3.2	3.5	● GS5007V5
12S	12	16.9	2	2.2	4.5	● GS5008V5
12	12	19.3	2.9	3.2	4.5	● GS5009V5
14S	14	18.9	2	2.2	4.5	● GS5010V5
14	14	21.3	2.9	3.2	4.5	● GS5011V5
15S	15	19.9	2	2.2	4.5	● GS5012V5
15	15	22.3	2.9	3.2	4.5	● GS5013V5
16S	16	20.9	2	2.2	4.5	● GS5014V5
16	16	23.3	2.9	3.2	4.5	● GS5015V5
18S	18	22.9	2	2.2	4.5	● GS5016V5
18	18	25.3	2.9	3.2	4.5	● GS5017V5
20S	20	27.3	2.9	3.2	4.5	● GS5018V5
20	20	30.7	3.9	4.2	4.5	● GS5019V5
22S	22	29.3	2.9	3.2	4.5	● GS5020V5
22	22	32.7	3.9	4.2	4.5	● GS5021V5
22.4S	22.4	29.7	2.9	3.2	4.5	● GS5022V5
22.4	22.4	33.1	3.9	4.2	4.5	● GS5023V5
25S	25	32.3	2.9	3.2	5.5	● GS5024V5
25	25	35.7	3.9	4.2	5.5	● GS5025V5
28S	28	35.3	2.9	3.2	5.5	● GS5026V5
28	28	38.7	3.9	4.2	5.5	● GS5027V5
30S	30	37.3	2.9	3.2	5.5	● GS5028V5
30	30	40.7	3.9	4.2	5.5	● GS5029V5
32S	32	39.3	2.9	3.2	5.5	GS5030V5
32	32	42.7	3.9	4.2	5.5	GS5031V5
35S	35	42.3	2.9	3.2	5.5	GS5032V5
35	35	45.7	3.9	4.2	5.5	GS5033V5
35.5S	35.5	42.8	2.9	3.2	5.5	GS5034V5
35.5	35.5	46.2	3.9	4.2	5.5	GS5035V5

Remark) When using the packing with ●, provide separate grooves.

HOW TO DETERMINE B DIMENSION

To determine B dimension, please refer to the graph in the right for the maximum extrusion gap (one side) considering the eccentricity of operating condition of the piston.

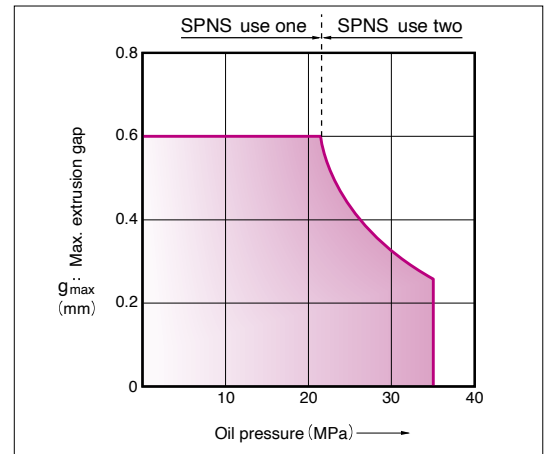

Nominal Number	Nominal Size of Packing, and Housing dimensions					NOK Part Number
	d	D	h	H	C	
SPNS 36S	36	43.3	2.9	3.2	5.5	GS5036V5
36	36	46.7	3.9	4.2	5.5	GS5037V5
38S	38	48.7	3.9	4.2	5.5	GS5038V5
38	38	53.1	5.9	6.3	5.5	GS5039V5
40S	40	50.7	3.9	4.2	5.5	GS5040V5
40	40	55.1	5.9	6.3	5.5	GS5041V5
42S	42	52.7	3.9	4.2	5.5	GS5042V5
42	42	57.1	5.9	6.3	5.5	GS5043V5
45S	45	55.7	3.9	4.2	5.5	GS5044V5
45	45	60.1	5.9	6.3	5.5	GS5045V5
50S	50	60.7	3.9	4.2	5.5	GS5046V5
50	50	65.1	5.9	6.3	5.5	GS5047V5
56S	56	66.7	3.9	4.2	7	GS5048V5
56	56	71.1	5.9	6.3	7	GS5049V5
60S	60	70.7	3.9	4.2	7	GS5050V5
60	60	75.1	5.9	6.3	7	GS5051V5
63	63	78.1	5.9	6.3	7	GS5052V5
65	65	80.1	5.9	6.3	7	GS5053V5
67	67	82.1	5.9	6.3	7	GS5054V5
70	70	85.1	5.9	6.3	7	GS5055V5
71	71	86.1	5.9	6.3	7	GS5056V5
75	75	90.1	5.9	6.3	7	GS5057V5
80	80	95.1	5.9	6.3	7	GS5058V5
85	85	100.1	5.9	6.3	7	GS5059V5
90	90	105.1	5.9	6.3	7	GS5060V5
95	95	110.1	5.9	6.3	7	GS5061V5
100	100	115.1	5.9	6.3	7	GS5062V5
105	105	120.1	5.9	6.3	7	GS5063V5
110	110	125.1	5.9	6.3	7	GS5064V5
112	112	127.1	5.9	6.3	7	GS5065V5
115	115	130.1	5.9	6.3	7	GS5066V5
120	120	135.1	5.9	6.3	7	GS5067V5
125	125	140.1	5.9	6.3	7	GS5068V5
130	130	145.1	5.9	6.3	7	GS5069V5
135	135	150.1	5.9	6.3	7	GS5070V5
140	140	155.1	5.9	6.3	7	GS5071V5
150	150	165.1	5.9	6.3	7	GS5072V5
160	160	175.1	5.9	6.3	7	GS5073V5
170	170	185.1	5.9	6.3	7	GS5074V5
180	180	195.1	5.9	6.3	7	GS5075V5

SPNC TYPE

**SPECIAL PACKINGS
FOR ROD SEALS**

**RAREFLON (PTFE) +
NITRILE RUBBER (NBR)**



E
DIMENSION
SPNC

- Please designate NOK Part number and type & size on your order.

(Example) · Type Dimensions SPNC 3 6 2.3

└── Type Sign └── Nominal Size of Packing
described in order of
inner diameter(d), outer diameter(D), and height(h)

· Part Number GS2000F0

- Please check the application range on pages 16 and 17 before selecting the type.

Material	NOK 31BF + NOK A305
-----------------	---------------------

SPNC^{TYPE} SPECIAL PACKINGS FOR ROD SEALS

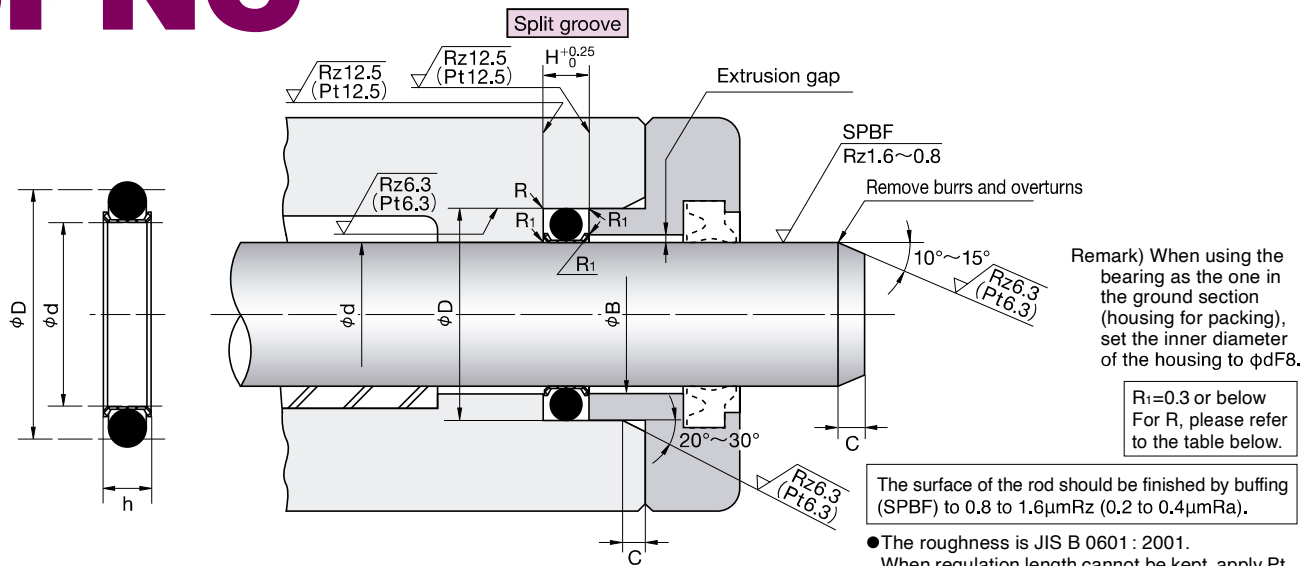

●The roughness is JIS B 0601 : 2001.
When regulation length cannot be kept, apply Pt.

Nominal Number	Nominal Size of Packing			Housing dimensions								NOK Part Number			
				For general hydraulic use				For pneumatic and hydraulic low-friction applications					H	R	C
				d	D	h	$\phi d_{-0.05}^0$	$\phi D_{+0.05}^0$	$\phi d_{-0.05}^0$	$\phi D_{+0.05}^0$					
SPNC 3	3	6	2.3	3	6	3	6.5	2.5	0.3 or below	3~4	GS2000F0				
4	4	7	2.3	4	7	4	7.5	2.5	0.3 or below	3~4	GS2001F0				
5	5	8	2.3	5	8	5	8.5	2.5	0.3 or below	3~4	GS2002F0				
6	6	9	2.3	6	9	6	9.5	2.5	0.3 or below	3~4	GS2003F0				
7	7	10	2.3	7	10	7	10.5	2.5	0.3 or below	3~4	GS2004F0				
8	8	11	2.3	8	11	8	11.5	2.5	0.3 or below	3~4	GS2005F0				
9	9	12	2.3	9	12	9	12.5	2.5	0.3 or below	3~4	GS2006F0				
10	10	13	2.3	10	13	10	13.5	2.5	0.3 or below	3~4	GS2007F0				
Nominal Number	Nominal Size of Packing			Housing dimensions								NOK Part Number			
				For general hydraulic use				For pneumatic and hydraulic low-friction applications					H	R	C
				d	D	h	$\phi d_{-0.06}^0$	$\phi D_{+0.06}^0$	$\phi d_{-0.06}^0$	$\phi D_{+0.06}^0$					
SPNC 10A	10	14	3	10	14	10	14.6	3.2	0.4 or below	4~5	GS2008F0				
11	11	15	3	11	15	11	15.6	3.2	0.4 or below	4~5	GS2009F0				
11.2	11.2	15.2	3	11.2	15.2	11.2	15.8	3.2	0.4 or below	4~5	GS2010F0				
12	12	16	3	12	16	12	16.6	3.2	0.4 or below	4~5	GS2011F0				
12.5	12.5	16.5	3	12.5	16.5	12.5	17.1	3.2	0.4 or below	4~5	GS2012F0				
14	14	18	3	14	18	14	18.6	3.2	0.4 or below	4~5	GS2013F0				
15	15	19	3	15	19	15	19.6	3.2	0.4 or below	4~5	GS2014F0				
16	16	20	3	16	20	16	20.6	3.2	0.4 or below	4~5	GS2015F0				
18	18	22	3	18	22	18	22.6	3.2	0.4 or below	4~5	GS2016F0				
20	20	24	3	20	24	20	24.6	3.2	0.4 or below	4~5	GS2017F0				
21	21	25	3	21	25	21	25.6	3.2	0.4 or below	4~5	GS2018F0				
22	22	26	3	22	26	22	26.6	3.2	0.4 or below	4~5	GS2020F0				
Nominal Number	Nominal Size of Packing			Housing dimensions								NOK Part Number			
				For general hydraulic use				For pneumatic and hydraulic low-friction applications					H	R	C
				d	D	h	$\phi d_{-0.08}^0$	$\phi D_{+0.08}^0$	$\phi d_{-0.08}^0$	$\phi D_{+0.08}^0$					
SPNC 22A	22	28	4.4	22	28	22	28.6	4.7	0.7 or below	5~6	GS2019F0				
22.4	22.4	28.4	4.4	22.4	28.4	22.4	29	4.7	0.7 or below	5~6	GS2021F0				
24	24	30	4.4	24	30	24	30.6	4.7	0.7 or below	5~6	GS2022F0				
25	25	31	4.4	25	31	25	31.6	4.7	0.7 or below	5~6	GS2023F0				
25.5	25.5	31.5	4.4	25.5	31.5	25.5	32.1	4.7	0.7 or below	5~6	GS2024F0				
26	26	32	4.4	26	32	26	32.6	4.7	0.7 or below	5~6	GS2025F0				
28	28	34	4.4	28	34	28	34.6	4.7	0.7 or below	5~6	GS2026F0				
29	29	35	4.4	29	35	29	35.6	4.7	0.7 or below	5~6	GS2027F0				
29.5	29.5	35.5	4.4	29.5	35.5	29.5	36.1	4.7	0.7 or below	5~6	GS2028F0				
30	30	36	4.4	30	36	30	36.6	4.7	0.7 or below	5~6	GS2029F0				
31	31	37	4.4	31	37	31	37.6	4.7	0.7 or below	5~6	GS2030F0				
31.5	31.5	37.5	4.4	31.5	37.5	31.5	38.1	4.7	0.7 or below	5~6	GS2031F0				
32	32	38	4.4	32	38	32	38.6	4.7	0.7 or below	5~6	GS2032F0				
34	34	40	4.4	34	40	34	40.6	4.7	0.7 or below	5~6	GS2033F0				
35	35	41	4.4	35	41	35	41.6	4.7	0.7 or below	5~6	GS2034F0				
35.5	35.5	41.5	4.4	35.5	41.5	35.5	42.1	4.7	0.7 or below	5~6	GS2035F0				
36	36	42	4.4	36	42	36	42.6	4.7	0.7 or below	5~6	GS2036F0				

HOW TO DETERMINE B DIMENSION

To determine B dimension, please make the maximum extrusion gap 0.4mm or below considering the eccentricity of piston.

Nominal Number	Nominal Size of Packing d D h			Housing dimensions							NOK Part Number
				For general hydraulic use		For pneumatic and hydraulic low-friction applications		H	R	C	
				$\phi d_{-0.08}^0$	$\phi D_{+0.08}^0$	$\phi d_{-0.08}^0$	$\phi D_{+0.08}^0$				
SPNC 38	38	44	4.4	38	44	38	44.6	4.7	0.7 or below	5~6	GS2037F0
39	39	45	4.4	39	45	39	45.6	4.7	0.7 or below	5~6	GS2038F0
40	40	46	4.4	40	46	40	46.6	4.7	0.7 or below	5~6	GS2039F0
41	41	47	4.4	41	47	41	47.6	4.7	0.7 or below	5~6	GS2040F0
42	42	48	4.4	42	48	42	48.6	4.7	0.7 or below	5~6	GS2041F0
44	44	50	4.4	44	50	44	50.6	4.7	0.7 or below	5~6	GS2042F0
45	45	51	4.4	45	51	45	51.6	4.7	0.7 or below	5~6	GS2043F0
46	46	52	4.4	46	52	46	52.6	4.7	0.7 or below	5~6	GS2044F0
48	48	54	4.4	48	54	48	54.6	4.7	0.7 or below	5~6	GS2046F0
49	49	55	4.4	49	55	49	55.6	4.7	0.7 or below	5~6	GS2047F0
50	50	56	4.4	50	56	50	56.6	4.7	0.7 or below	5~6	GS2049F0

Nominal Number	Nominal Size of Packing d D h			Housing dimensions							NOK Part Number
				For general hydraulic use		For pneumatic and hydraulic low-friction applications		H	R	C	
				$\phi d_{-0.10}^0$	$\phi D_{+0.10}^0$	$\phi d_{-0.10}^0$	$\phi D_{+0.10}^0$				
SPNC 48A	48	58	7	48	58	48	58.6	7.5	0.8 or below	6~8	GS2045F0
50A	50	60	7	50	60	50	60.6	7.5	0.8 or below	6~8	GS2048F0
52	52	62	7	52	62	52	62.6	7.5	0.8 or below	6~8	GS2050F0
53	53	63	7	53	63	53	63.6	7.5	0.8 or below	6~8	GS2051F0
55	55	65	7	55	65	55	65.6	7.5	0.8 or below	6~8	GS2052F0
56	56	66	7	56	66	56	66.6	7.5	0.8 or below	6~8	GS2053F0
58	58	68	7	58	68	58	68.6	7.5	0.8 or below	6~8	GS2054F0
60	60	70	7	60	70	60	70.6	7.5	0.8 or below	6~8	GS2055F0
62	62	72	7	62	72	62	72.6	7.5	0.8 or below	6~8	GS2056F0
63	63	73	7	63	73	63	73.6	7.5	0.8 or below	6~8	GS2057F0
65	65	75	7	65	75	65	75.6	7.5	0.8 or below	6~8	GS2058F0
67	67	77	7	67	77	67	77.6	7.5	0.8 or below	6~8	GS2059F0
70	70	80	7	70	80	70	80.6	7.5	0.8 or below	6~8	GS2060F0
71	71	81	7	71	81	71	81.6	7.5	0.8 or below	6~8	GS2061F0
75	75	85	7	75	85	75	85.6	7.5	0.8 or below	6~8	GS2062F0
80	80	90	7	80	90	80	90.6	7.5	0.8 or below	6~8	GS2063F0
85	85	95	7	85	95	85	95.6	7.5	0.8 or below	6~8	GS2064F0
90	90	100	7	90	100	90	100.6	7.5	0.8 or below	6~8	GS2065F0
95	95	105	7	95	105	95	105.6	7.5	0.8 or below	6~8	GS2066F0
100	100	110	7	100	110	100	110.6	7.5	0.8 or below	6~8	GS2067F0
102	102	112	7	102	112	102	112.6	7.5	0.8 or below	6~8	GS2068F0
105	105	115	7	105	115	105	115.6	7.5	0.8 or below	6~8	GS2069F0
110	110	120	7	110	120	110	120.6	7.5	0.8 or below	6~8	GS2070F0
112	112	122	7	112	122	112	122.6	7.5	0.8 or below	6~8	GS2071F0
115	115	125	7	115	125	115	125.6	7.5	0.8 or below	6~8	GS2072F0
120	120	130	7	120	130	120	130.6	7.5	0.8 or below	6~8	GS2073F0
125	125	135	7	125	135	125	135.6	7.5	0.8 or below	6~8	GS2074F0
130	130	140	7	130	140	130	140.6	7.5	0.8 or below	6~8	GS2075F0
132	132	142	7	132	142	132	142.6	7.5	0.8 or below	6~8	GS2076F0

E DIMENSION
SPNC

SPNC^{TYPE} SPECIAL PACKINGS FOR ROD SEALS

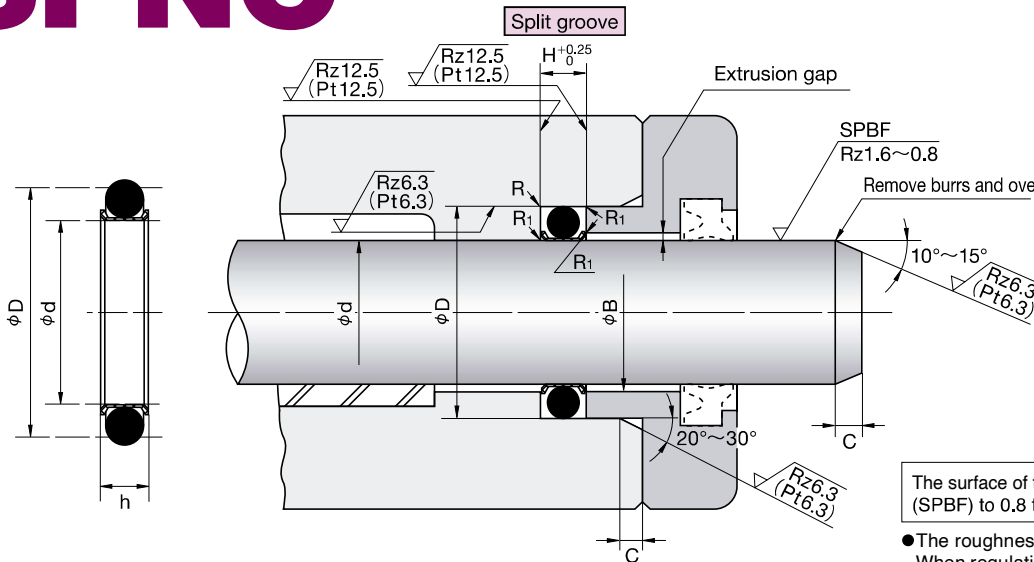

Remark 1) To determine φB dimension, please make the maximum extrusion gap 0.4mm or below considering the eccentricity of rod.
 Remark 2) When using the bearing as the one in the ground section (housing for packing), set the inner diameter of the housing to φdF8.

R₁=0.3 or below
 For R, please refer to the table below.

The surface of the rod should be finished by buffing (SPBF) to 0.8 to 1.6μmRz (0.2 to 0.4μmRa).

●The roughness is JIS B 0601 : 2001.
 When regulation length cannot be kept, apply Pt.

Nominal Number	Nominal Size of Packing			Housing dimensions						NOK Part Number	
				For general hydraulic use		For pneumatic and hydraulic low-friction applications		H	R		C
	d	D	h	φd _{-0.10} ⁰	φD ^{+0.10} ₀	φd _{-0.10} ⁰	φD ^{+0.10} ₀				
SPNC 135	135	145	7	135	145	135	145.6	7.5	0.8 or below	6~8	GS2077F0
140	140	150	7	140	150	140	150.6	7.5	0.8 or below	6~8	GS2078F0
145	145	155	7	145	155	145	155.6	7.5	0.8 or below	6~8	GS2079F0
150	150	160	7	150	160	150	160.6	7.5	0.8 or below	6~8	GS2081F0
150A	150	165	10.5	150	165	150	165.6	11.0	0.8 or below	8~12	GS2080F0
155	155	170	10.5	155	170	155	170.6	11.0	0.8 or below	8~12	GS2082F0
160	160	175	10.5	160	175	160	175.6	11.0	0.8 or below	8~12	GS2083F0
165	165	180	10.5	165	180	165	180.6	11.0	0.8 or below	8~12	GS2084F0
170	170	185	10.5	170	185	170	185.6	11.0	0.8 or below	8~12	GS2085F0
175	175	190	10.5	175	190	175	190.6	11.0	0.8 or below	8~12	GS2086F0
180	180	195	10.5	180	195	180	195.6	11.0	0.8 or below	8~12	GS2087F0
185	185	200	10.5	185	200	185	200.6	11.0	0.8 or below	8~12	GS2088F0
190	190	205	10.5	190	205	190	205.6	11.0	0.8 or below	8~12	GS2089F0
195	195	210	10.5	195	210	195	210.6	11.0	0.8 or below	8~12	GS2090F0
200	200	215	10.5	200	215	200	215.6	11.0	0.8 or below	8~12	GS2091F0
205	205	220	10.5	205	220	205	220.6	11.0	0.8 or below	8~12	GS2092F0
209	209	224	10.5	209	224	209	224.6	11.0	0.8 or below	8~12	GS2093F0
210	210	225	10.5	210	225	210	225.6	11.0	0.8 or below	8~12	GS2094F0
215	215	230	10.5	215	230	215	230.6	11.0	0.8 or below	8~12	GS2095F0
220	220	235	10.5	220	235	220	235.6	11.0	0.8 or below	8~12	GS2096F0
225	225	240	10.5	225	240	225	240.6	11.0	0.8 or below	8~12	GS2097F0
230	230	245	10.5	230	245	230	245.6	11.0	0.8 or below	8~12	GS2098F0
235	235	250	10.5	235	250	235	250.6	11.0	0.8 or below	8~12	GS2099F0
240	240	255	10.5	240	255	240	255.6	11.0	0.8 or below	8~12	GS2100F0
245	245	260	10.5	245	260	245	260.6	11.0	0.8 or below	8~12	GS2101F0
250	250	265	10.5	250	265	250	265.6	11.0	0.8 or below	8~12	GS2102F0
255	255	270	10.5	255	270	255	270.6	11.0	0.8 or below	8~12	GS2103F0
260	260	275	10.5	260	275	260	275.6	11.0	0.8 or below	8~12	GS2104F0
265	265	280	10.5	265	280	265	280.6	11.0	0.8 or below	8~12	GS2105F0
270	270	285	10.5	270	285	270	285.6	11.0	0.8 or below	8~12	GS2106F0
275	275	290	10.5	275	290	275	290.6	11.0	0.8 or below	8~12	GS2107F0
280	280	295	10.5	280	295	280	295.6	11.0	0.8 or below	8~12	GS2108F0
285	285	300	10.5	285	300	285	300.6	11.0	0.8 or below	8~12	GS2109F0
290	290	305	10.5	290	305	290	305.6	11.0	0.8 or below	8~12	GS2110F0
295	295	310	10.5	295	310	295	310.6	11.0	0.8 or below	8~12	GS2111F0
300	300	315	10.5	300	315	300	315.6	11.0	0.8 or below	8~12	GS2112F0
315	315	330	10.5	315	330	315	330.6	11.0	0.8 or below	8~12	GS2113F0
320	320	335	10.5	320	335	320	335.6	11.0	0.8 or below	8~12	GS2114F0
335	335	350	10.5	335	350	335	350.6	11.0	0.8 or below	8~12	GS2115F0
340	340	355	10.5	340	355	340	355.6	11.0	0.8 or below	8~12	GS2116F0
355	355	370	10.5	355	370	355	370.6	11.0	0.8 or below	8~12	GS2117F0
360	360	375	10.5	360	375	360	375.6	11.0	0.8 or below	8~12	GS2118F0
375	375	390	10.5	375	390	375	390.6	11.0	0.8 or below	8~12	GS2119F0
385	385	400	10.5	385	400	385	400.6	11.0	0.8 or below	8~12	GS2120F0

E DIMENSION SPNC

UPI TYPE

PACKINGS FOR BOTH PISTON AND ROD SEALS IRON RUBBER (PUR)



● Please designate NOK Part number and type & size on your order.

(Example) Order for the packing as a single piece

· Type Dimensions	<u>UPI</u>	<u>6.3</u>	<u>16.3</u>	<u>8</u>	
	└─ Type Sign	└─ Nominal Size of Packing described in order of inner diameter(d), outer diameter(D), and height(h)			
· Part Number	FU0024D0				

※ When placing orders for backup rings used in combination with packing, designate the NOK part number and the model size.

· Type Dimensions	<u>BRT3</u>	<u>6.3</u>	<u>16.3</u>	<u>2</u>	
	└─ Type Sign	└─ Nominal Size of Backup ring described in order of inner diameter(d), outer diameter(D), and thickness(t)*			
· Part Number	GN0720V0				* t = H _B -H _A (Housing dimensions)

● Please check the application range on pages 18 and 19 before selecting the type.

Material	NOK U801
-----------------	----------

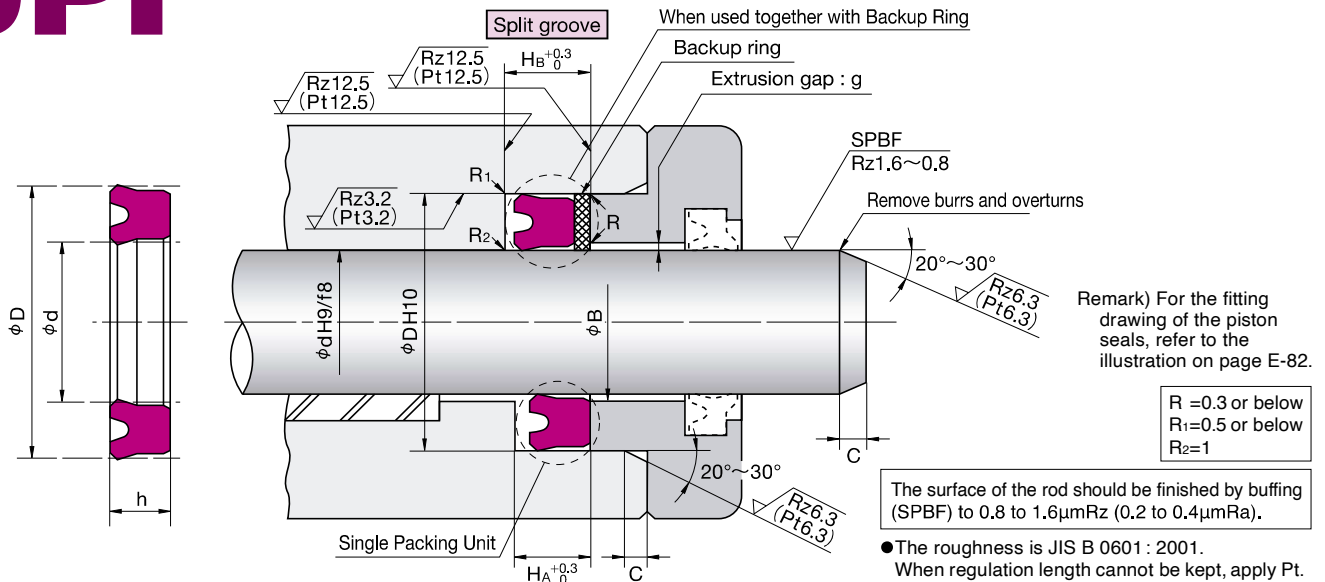

Nominal Size of Packing, and Housing dimensions							Packing Part Number	Combination Backup Ring Part Number	
d	D	h	H _A	H _B	φD ₁	C		BRT3 (Endless) 19YF	BRN3 (Endless) 80NP
6.3	16.3	8	9	11	15.3	2.5	FU0024D0	GN0720V0	GN9823O0
7.1	17.1	8	9	11	16.1	2.5	FU0030D0	GN0723V0	GN9868O0
8	18	8	9	11	17	2.5	FU0043D0	GN0725V0	GN9101O1
9	19	8	9	11	18	2.5	FU0054D0	GN0728V0	GN9826O0
10	20	8	9	11	19	2.5	FU0069D0	GN0733V0	GN9102O1
11.2	21.2	8	9	11	20.2	2.5	FU0081D0	GN0736V0	GN9828O0
12	25	8	9	11	24	2.5	FU0093D0	GN6005V0	GN9869O0
12.5	22.5	8	9	11	21.5	2.5	FU0102D0	GN0741V0	GN9830O0
14	24	8	9	11	23	2.5	FU0122D0	GN0745V0	GN9103O1
15	25	8	9	11	24	2.5	FU0135D0	GN0749V0	GN9738O1
16	26	8	9	11	25	2.5	FU0157D0	GN0751V0	GN9105O1
16	32	10	11	13	31	2.5	FU0161D0	GN7288V0	GN9870O0
18	28	8	9	11	27	3.5	FU0182D0	GN0757V0	GN9833O0
18	31	10	11	13	30	3.5	FU0186D0	GN6446V0	GN9107O1
20	30	8	9	11	29	3.5	FU0215D0	GN0762V0	GN9109O1
20	33	10	11	13	32	3.5	FU0221D0	GN6448V0	GN9110O1
20	35	10	11	13	34	3.5	FU0224D0	GN7289V0	GN9871O0
21.5	31.5	8	9	11	30.5	3.5	FU0239D0	GN0767V0	GN9797O0
22	32	8	9	11	31	3.5	FU0246D0	GN7290V0	GN9872O0
22	35	10	11	13	34	3.5	FU0249D0	GN6449V0	GN9111O1
22.4	30	5	5.7	7.7	29	3.5	FU0260D0	GN6450V0	GN9112O1
22.4	32.4	8	9	11	31.4	3.5	FU0263D0	GN0771V0	GN9834O0
25	35	8	9	11	34	3.5	FU0282D0	GN0781V0	GN9115O1
25	38	8	9	11	37	3.5	FU0287D0	GN6453V0	GN9116O1
25	40	10	11	13	39	3.5	FU0292D0	GN6591V0	GN9800O0
25	45	12	13	15	44	3.5	FU0301D0	GN7291V0	GN9873O0
25.5	35.5	8	9	11	34.5	3.5	FU0309D1	GN6454V0	GN9117O1
28	35.5	5	5.7	8.7	34.5	3.5	FU0320D1	GN6456V0	GN9119O1
28	40	10	11	14	39	3.5	FU0330D0	GN6457V0	GN9120O1
28	43	10	11	14	42	3.5	FU0340D0	GN0791V0	GN9836O0
30	45	10	11	14	44	3.5	FU0368D0	GN7061V0	GN9801O0
30	46	10	11	14	45	3.5	FU0369D0	GN7292V0	GN9874O0
31.5	46.5	10	11	14	45.5	3.5	FU0387D0	GN0805V0	GN9837O0
32	46	10	11	14	45	4	FU0403D0	GN6035V0	GN9875O0
35	50	10	11	14	49	4	FU0437D0	GN0816V0	GN9128O1
35.5	45	6	7	10	44	4	FU0451D0	GN6464V0	GN9129O1
35.5	50.5	10	11	14	49.5	4	FU0456D0	GN0820V0	GN9954O0
38	52	10	11	14	51	4	FU0470D0	GN6046V0	GN9876O0
40	55	10	11	14	54	4	FU0505D0	GN6759V0	GN9948O0
40	56	10	11	14	55	4	FU0508D0	GN6466V0	GN9132O1
40	60	12	13	16	59	4	FU0514D0	GN7293V0	GN9877O0
41	56	10	11	14	55	4	FU0523D0	GN0835V0	GN9949O0

E-PC-1

HOW TO DETERMINE B DIMENSION

■ When using backup ring

Please determine B dimension according to the table below. If you require smaller B dimension (in case of piston seals) or larger B dimension (in case of rod seals) because of the cylinder configuration, please consult NOK.

Maximum Service Pressure	14MPa	21MPa	35MPa	35MPa	
Material of Backup ring	19YF			80NP	
B Dimension	For rod	$B \leq \phi d + 1.0$	$B \leq \phi d + 0.5$	$B \leq \phi d + 0.2$	$B \leq \phi d + 0.8$
	For piston	$B \geq \phi D - 1.0$	$B \geq \phi D - 0.5$	$B \geq \phi D - 0.2$	$B \geq \phi D - 0.8$

■ When not using backup ring

To determine B dimension, please refer to the graph in the right for the maximum extrusion gap (one side) considering the eccentricity of operating condition of the piston or rod.

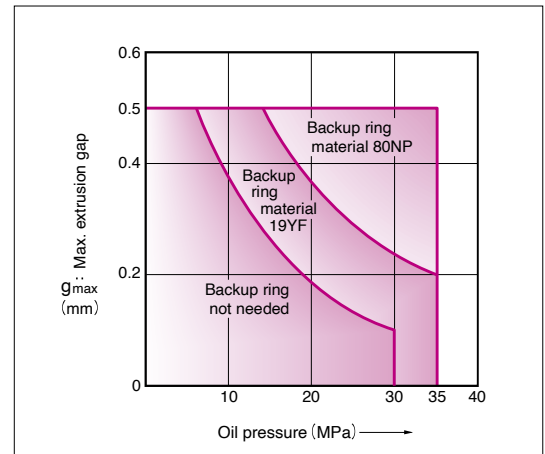

Nominal Size of Packing, and Housing dimensions							Packing Part Number	Combination Backup Ring Part Number	
d	D	h	H _A	H _B	φD ₁	C		BRT3 (Endless)	BRN3 (Endless)
								19YF	80NP
45	56	7	8	11	55	4	FU0572D1	GN6468V0	GN9134O1
45	60	10	11	14	59	4	FU0577D0	GN0845V0	GN9950O0
45	61	10	11	14	60	4	FU0579D0	GN6469V0	GN9135O1
46	60	10	11	14	59	4	FU0588D0	GN7294V0	GN9878O0
48	63	10	11	14	62	4	FU0601D0	GN0853V0	GN9951O0
50	65	10	11	14	64	4	FU0631D0	GN6439V0	GN9952O0
50	66	12	13	16	65	4	FU0635D0	GN6329V0	GN9139O1
50	70	12	13	16	69	4	FU0639D0	GN6592V0	GN9529O0
51	71	12	13	16	70	4	FU0669D0	GN0862V0	GN9805O0
53	73	12	13	16	72	4	FU0683D0	GN0869V0	GN9879O0
55	71	12	13	16	70	4	FU0704D0	GN6473V0	GN9142O1
55	75	12	13	16	74	4	FU0708D0	GN7249V0	GN9807O0
55	80	15	16	19	79	4	FU0712D0	GN6072V0	GN9880O0
56	72	12	13	16	71	4	FU0727D0	GN7009V0	GN9838O0
56	76	12	13	16	75	4	FU0728D0	GN0877V0	GN9839O0
58	78	12	13	16	77	4	FU0736D0	GN7296V0	GN9881O0
60	71	7	8	11	70	4	FU0750D0	GN6475V0	GN9145O1
60	80	12	13	16	79	4	FU0761D0	GN0886V1	GN9953O0
62	82	12	13	16	81	4	FU0777D0	GN6371V0	GN9882O0
63	83	12	13	16	82	4	FU0793D0	GN0893V1	GN9842O0
65	85	12	13	16	84	5	FU0819D0	GN0899V0	GN9810O0
67	87	12	13	16	86	5	FU0831D0	GN0904V0	GN9844O0
70	90	12	13	16	89	5	FU0862D0	GN0910V0	GN9151O1
71	80	6	7	10	79	5	FU0879D1	GN6481V0	GN9152O1
71	91	12	13	16	90	5	FU0884D0	GN0914V0	GN9846O0
75	95	12	13	16	94	5	FU0910D0	GN0920V0	GN9154O1
80	100	12	13	16	98	5	FU0948D0	GN0927V0	GN9156O1
80	100	15	16	19	98	5	FU0949D0	GN0927V0	GN9156O1
85	100	9	10	13	98	5	FU0984D1	GN6484V0	GN9091O1
85	105	12	13	16	103	5	FU0989D0	GN0932V0	GN9157O1
90	110	12	13	16	108	5	FU1030D0	GN0939V0	GN9159O1
92	112	12	13	16	110	5	FU1042D0	GN0940V0	GN9811O0
95	115	12	13	16	113	5	FU1056D0	GN0945V0	GN9161O1
95	120	15	16	19	118	5	FU1061D0	GN6716V0	GN9883O0
98	112	9	10	13	110	5	FU1068D0	GN6487V0	GN9162O1
100	120	12	13	16	118	5	FU1089D0	GN0952V0	GN9164O1
100	125	15	17	20	123	5	FU1096D0	GN7297V0	GN9884O0
105	125	15	17	20	123	5	FU1129D0	GN0959V0	GN9165O1
106	120	8.5	9.5	12.5	118	5	FU1135D1	GN6489V0	GN9166O1
106	126	15	17	20	124	5	FU1138D0	GN0961V0	GN9847O0
110	130	15	17	20	128	5	FU1165D0	GN6790V0	GN9694O0
112	132	15	17	20	130	5	FU1182D0	GN0970V0	GN9168O1

UPI TYPE PACKINGS FOR BOTH PISTON AND ROD SEALS

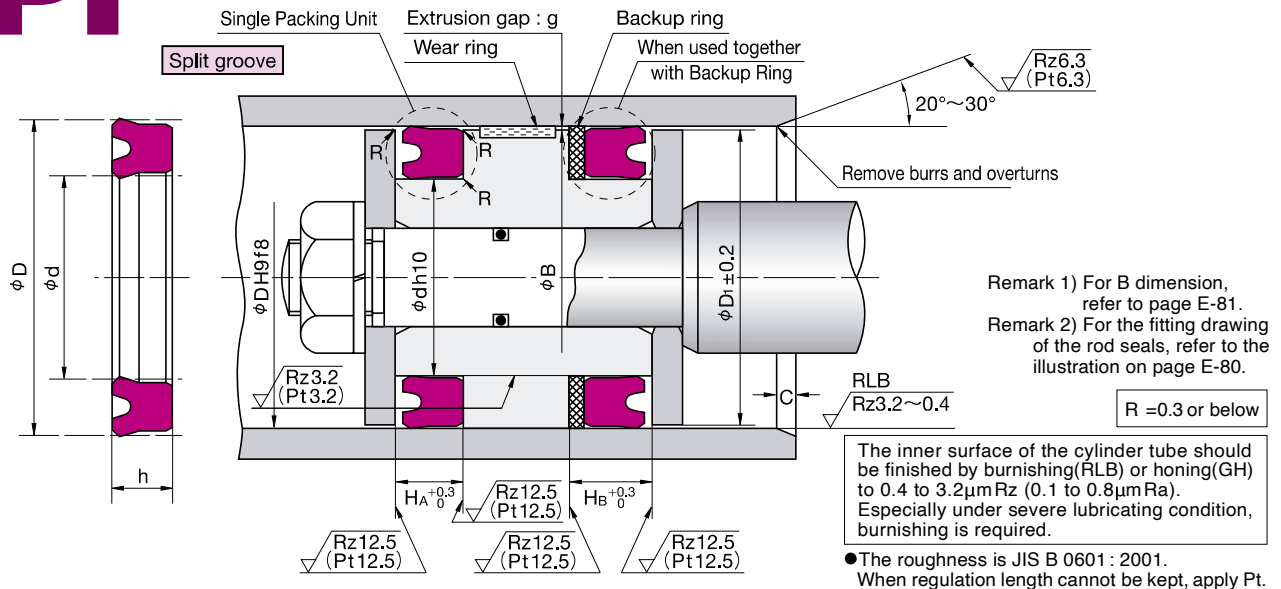

Nominal Size of Packing, and Housing dimensions							Packing Part Number	Combination Backup Ring Part Number	
d	D	h	HA	HB	φD ₁	C		BRT3 (Endless) 19YF	BRN3 (Endless) 80NP
115	135	15	17	20	133	5	FU1198D0	GN0974V0	GN9778O1
118	132	9	10	13	130	5	FU1932D0	GN7298V0	GN9885O0
118	138	15	17	20	136	5	FU1207D0	GN0978V0	GN9849O0
120	140	15	17	20	138	5	FU1224D0	GN0982V0	GN9169O1
125	145	15	17	20	143	5	FU1257D0	GN0986V0	GN9850O0
130	150	15	17	20	148	6.5	FU1284D0	GN6925V0	GN9335O1
132	152	15	17	20	150	6.5	FU1292D0	GN0994V0	GN9886O0
135	155	15	17	20	153	6.5	FU1305D0	GN0998V0	GN9769O0
136	150	9	10	13	148	6.5	FU1933D0	GN6493V0	GN9173O1
140	160	15	17	20	158	6.5	FU1327D0	GN1002V0	GN9668O0
140	165	15	17	20	163	6.5	FU1330D0	GN6494V0	GN9174O1
145	165	15	17	20	163	6.5	FU1344D0	GN1007V0	GN9887O0
150	170	15	17	20	168	6.5	FU1363D0	GN1011V0	GN9672O1
150	175	15	17	20	173	6.5	FU1365D0	GN7014V0	GN9645O1
155	180	15	17	21	178	6.5	FU1391D0	GN1016V0	GN9179O1
160	185	15	17	21	183	6.5	FU1413D0	GN1020V0	GN9181O1
165	190	15	17	21	188	6.5	FU1431D0	GN1023V0	GN9815O0
170	195	15	17	21	193	6.5	FU1448D0	GN1027V0	GN9852O0
175	200	15	17	21	198	6.5	FU1461D0	GN1031V0	GN9186O1
180	205	15	17	21	203	6.5	FU1490D0	GN1035V0	GN9188O1
185	210	15	17	21	208	6.5	FU1504D0	GN1039V0	GN9817O0
190	215	15	17	21	213	6.5	FU1519D0	GN1042V0	GN9818O0
199	224	15	17	21	222	6.5	FU1532D0	GN1047V0	GN9820O0
200	225	15	17	21	223	6.5	FU1547D0	GN1050V0	GN9192O1
200	225	18	20	24	223	6.5	FU1549D0	GN1050V0	GN9192O1
205	235	18	20	24	233	6.5	FU1565D0	GN7302V0	GN9888O0
210	235	18	20	24	233	6.5	FU1579D0	GN1057V0	GN9854O0
212	237	18	20	24	235	6.5	FU1584D0	GN1058V0	GN9665O1
220	245	18	20	24	243	6.5	FU1599D0	GN1063V0	GN9670O0
224	249	18	20	24	247	6.5	FU1612D0	GN7282V0	GN9856O0
225	250	18	20	24	248	6.5	FU1625D0	GN1065V0	GN9045O1
230	254	18	20	24	252	6.5	FU1639D0	GN7304V0	GN9890O0
230	255	18	20	24	253	6.5	FU1641D0	GN1069V0	GN9857O0
236	261	18	20	24	259	6.5	FU1648D0	GN6191V0	GN9891O0
240	265	18	20	24	263	6.5	FU1662D0	GN1073V0	GN9858O0
250	275	18	20	24	273	6.5	FU1682D0	GN1078V0	GN9200O1
260	290	18	20	24	288	8	FU1706D0	GN1083V0	GN9431O1
265	295	18	20	24	293	8	FU1713D0	GN1085V0	GN9892O0
270	300	18	20	24	298	8	FU1722D0	GN1089V0	GN9206O1
280	310	18	20	24	308	8	FU1735D0	GN1093V0	GN9859O0
290	320	18	20	24	318	8	FU1750D0	GN1098V0	GN9860O0
300	330	18	20	24	328	8	FU1764D0	GN1103V0	GN9235O1

UPI TYPE PACKINGS FOR BOTH PISTON AND ROD SEALS [Large size dimension table]

■ When using packings on this large size, please consult NOK.

Nominal Size of Packing, and Housing dimensions							Packing Part Number	Combination Backup Ring Part Number	
d	D	h	H _A	H _B	φD ₁	C		BRT3 (Endless) 19YF	BRN3 (Endless) 80NP
310	340	22	24	28	338	10	FU1773D0		
315	345	22	24	28	343	10	FU1775D0		
320	350	15	17	21	348	10	FU1778D0		
320	350	18	20	24	348	10	FU1779D0		
320	350	22	24	28	348	10	FU1780D0		
320	360	25	27	31	358	10	FU1781D0		
323	355	24	26	30	353	10	FU1784D0		
330	360	20	22	26	358	10	FU1788D0		
330	360	22	24	28	358	10	FU1789D0		
330	370	28	30	34	368	10	FU1791D0		
340	370	22	24	28	368	10	FU1795D0		
350	380	22	24	28	378	10	FU1799D0		
350	390	28	30	34	388	10	FU2016D0		
355	385	22	24	28	383	10	FU1801D0		
370	400	22	24	28	398	10	FU1809D0		
375	405	22	24	28	403	10	FU1812D0		
380	410	22	24	28	408	10	FU1816D0		
385	415	22	24	28	413	10	FU1993D0		
390	420	22	24	28	418	10	FU1818D0		
400	425	22	24	28	423	10	FU1822D0		
400	430	22	24	28	428	10	FU1823D0		
405	440	25	27	32	438	15	FU1827D0		
410	445	25	27	32	443	15	FU1829D0		
410	460	35	37	42	458	15	FU1830D0		
415	450	25	27	32	448	15	FU1831D0		
420	455	25	27	32	453	15	FU1833D0		
425	460	25	27	32	458	15	FU2223D0		
430	460	22	24	29	458	15	FU1977D0		
430	465	25	27	32	463	15	FU2013D0		
431	457.2	18	20	25	455	15	FU1839D1		
435	470	25	27	32	468	15	FU1841D0		
440	470	19	21	26	468	15	FU1842D0		
440	475	28	30	35	473	15	FU1976D0		
445	480	25	27	32	478	15	FU2428D0		
450	485	25	27	32	483	15	FU1845D0		

Remark) When placing orders for backup ring on this large size (the inner diameter(d) exceeding classification 300mm), please consult NOK.

E
DIMENSION
UPI

[Large size dimension table]

■ When using packings on this large size, please consult NOK.

Nominal Size of Packing, and Housing dimensions							Packing Part Number	Combination Backup Ring Part Number	
d	D	h	H _A	H _B	φD ₁	C		BRT3 (Endless) 19YF	BRN3 (Endless) 80NP
456	490	30	32	37	488	15	FU1847D1		
460	495	25	27	32	493	15	FU1849D0		
465	500	26.5	28.5	33.5	498	15	FU2648D0		
470	505	25	27	32	503	15	FU1851D0		
475	510	25	27	32	508	15	FU1854D0		
480	515	25	27	32	513	15	FU2025D0		
490	530	25	27	32	528	15	FU1855D0		
500	535	25	27	32	533	20	FU1856D0		
500	540	25	27	32	538	20	FU1857D0		
507	547	28	30	35	545	20	FU1858D0		
525	565	28	30	35	563	20	FU2743D0		
530	570	25	27	32	568	20	FU2718D0		
540	575	23	25	30	573	20	FU2376D0		
560	600	28	30	35	598	20	FU1865D0		
595	640	28	30	35	638	20	FU1986D0		
600	650	32	34	39	648	20	FU2017D0		
650	690	25	27	32	688	20	FU2003D0		
660	700	32	34	39	698	20	FU1870D0		
680	720	32	34	39	718	20	FU1871D0		
695	745	32	34	39	743	20	FU2398D0		
700	750	35	37	42	748	20	FU1874D0		
755	800	32	34	39	798	20	FU1876D0		
800	830	20	22	27	828	20	FU1978D0		
800	850	35	37	42	848	20	FU1881D0		
850	900	35	37	42	898	20	FU2219D0		
870	900	20	22	27	898	20	FU1979D0		
920	970	35	37	42	968	20	FU1888D1		
1050	1100	30	32	37	1098	20	FU2391D0		
1096	1146	30	32	37	1144	20	FU2558D0		
1150	1200	30	32	37	1198	20	FU2229D0		
1380	1430	30	32	37	1428	20	FU2392D0		

Remark) When placing orders for backup ring on this large size (the inner diameter(d) exceeding classification 300mm), please consult NOK.

USI TYPE

PACKINGS FOR BOTH PISTON AND ROD SEALS IRON RUBBER (PUR)



● Please designate NOK Part number and type & size on your order.

(Example) Order for the packing as a single piece

· Type Dimensions	USI	10	18	5
	└─ Type Sign	└─ Nominal Size of Packing described in order of inner diameter(d), outer diameter(D), and height(h)		
· Part Number	FU0064S0			

※ When placing orders for backup rings used in combination with packing, designate the NOK part number and the model size.

· Type Dimensions	BRT2	10	18	2
	└─ Type Sign	└─ Nominal Size of Backup ring described in order of inner diameter(d), outer diameter(D), and thickness(t)*		
· Part Number	GN5418V0	*t = H _B -H _A (Housing dimensions)		

● Please check the application range on pages 14 and 15 before selecting the type.

Material	NOK U593
-----------------	----------

USI TYPE PACKINGS FOR BOTH PISTON AND ROD SEALS (INSTALLED WITH INTERNAL GROOVE)

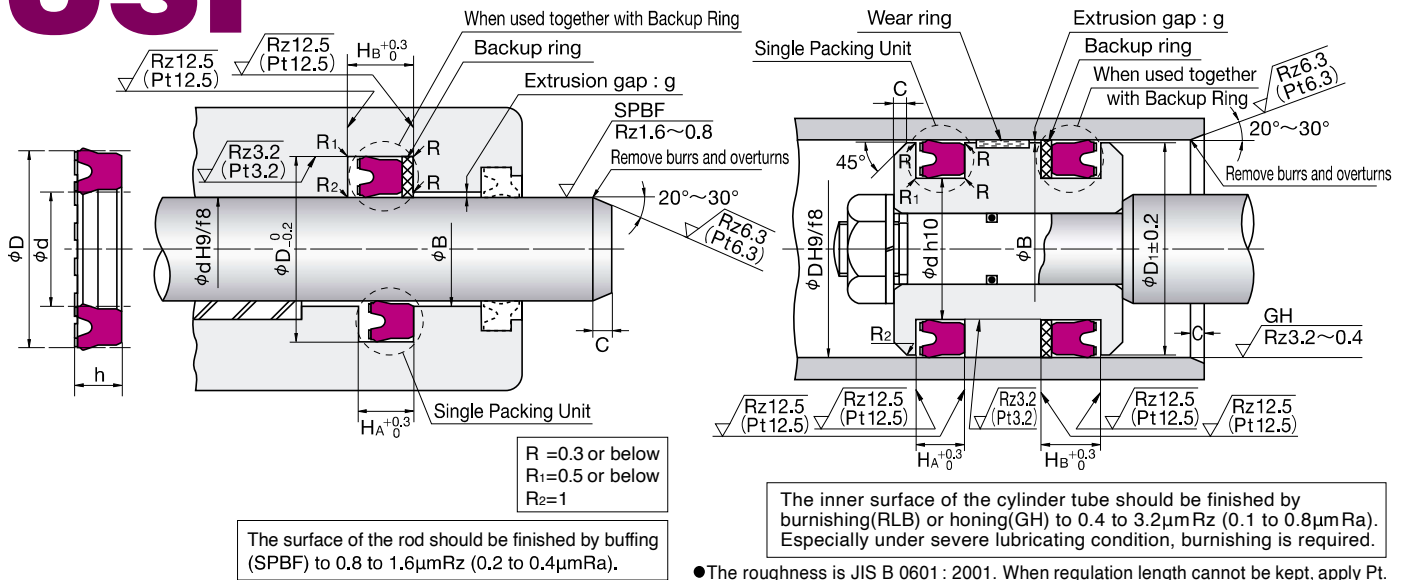

Nominal Size of Packing, and Housing dimensions							Packing Part Number	Combination Backup Ring Part Number
d	D	h	H _A	H _B	φD ₁	C		BRT2 (Biascut) 19YF
10	18	5	5.7	7.7	17	2	● FU0064S0	GN5418V0
12	20	5	5.7	7.7	19	2	● FU2464S0	GN5723V0
12.5	20	5	5.7	7.7	19	2	● FU2465S0	GN5724V0
14	22	5	5.7	7.7	21	2	○ FU0116S0	GN5719V0
16	24	5	5.7	7.7	23	2	○ FU0150S0	GN5720V0
17	25	5	5.7	7.7	24	2	○ FU2466S0	GN5725V0
18	26	5	5.7	7.7	25	2	○ FU0180S0	GN4778V0
20	28	5	5.7	7.7	27	2	○ FU0212S0	GN4780V0
20	30	6	7	9	29	2	○ FU0214S0	GN4781V0
22	30	5	5.7	7.7	29	2	○ FU2467S0	GN5726V0
22.4	30	5	5.7	7.7	29	2	○ FU0260S0	GN4784V0
23.5	31.5	5	5.7	7.7	30.5	2	○ FU0267S0	GN4786V0
24	32	5	5.7	7.7	31	2	○ FU2468S0	GN5727V0
25	33	5	5.7	7.7	32	2.5	○ FU0276S0	GN5019V1
25	35	6	7	9	34	2.5	○ FU0279S0	GN4787V0
26	34	5	5.7	8.7	33	2.5	○ FU2469S0	GN5728V0
27	35	5	5.7	8.7	34	2.5	FU2470S0	GN5707V0
28	35.5	5	5.7	8.7	34.5	2.5	FU0320S0	GN4791V0
28	36	5	5.7	8.7	35	2.5	FU0321S0	GN5715V0
30	38	5	5.7	8.7	37	2.5	FU0355S0	GN5729V0
30	40	6	7	10	39	2.5	FU0357S0	GN4794V0
31.5	41.5	6	7	10	40.5	2.5	FU0382S0	GN4796V0
32	42	6	7	10	41	2.5	FU2055S0	GN5730V0
33	43	6	7	10	42	2.5	FU2471S0	GN5731V0
34	44	6	7	10	43	2.5	FU2263S0	GN5732V0
35	45	6	7	10	44	2.5	FU0424S0	GN4799V0
35.5	45	6	7	10	44	2.5	FU0451S0	GN4801V0
35.5	45.5	6	7	10	44.5	2.5	FU0452S0	GN5716V0
36	46	6	7	10	45	2.5	FU2472S0	GN5733V0
38	48	6	7	10	47	2.5	FU2240S0	GN5365V0
40	50	6	7	10	49	2.5	FU0497S0	GN4050V0
45	55	6	7	10	54	2.5	FU0567S0	GN4804V0
45	56	7	8	11	55	2.5	FU0572S0	GN4805V0
46	56	6	7	10	55	2.5	FU2662S0	GN5709V0
50	60	6	7	10	59	2.5	FU0619S0	GN4335V0
53	63	6	7	10	62	2.5	FU0679S0	GN4693V0
55	65	6	7	10	64	2.5	FU0694S0	GN4810V0
56	66	6	7	10	65	2.5	FU0722S0	GN4766V0
58	68	6	7	10	67	2.5	FU2473S0	GN5641V0
60	70	6	7	10	69	2.5	FU0746S0	GN4676V0
60	71	7	8	11	70	2.5	FU0750S0	GN4812V0

Remark) When using packings with mark ● as rod packing, provide separate grooves.
When using packings with marks ●○ as piston packing, provide separate grooves.

HOW TO DETERMINE B DIMENSION

■ When using backup ring

Please determine B dimension according to the table below. If you require smaller B dimension (in case of piston seals) or larger B dimension (in case of rod seals) because of the cylinder configuration, please consult NOK.

Maximum Service Pressure	14MPa	21MPa
Material of Backup ring	19YF	
B Dimension	For rod	$B \leq \phi d + 1.0$
	For piston	$B \leq \phi D - 1.0$

■ When not using backup ring

To determine B dimension, please refer to the graph in the right for the maximum extrusion gap (one side) considering the eccentricity of operating condition of the piston or rod.

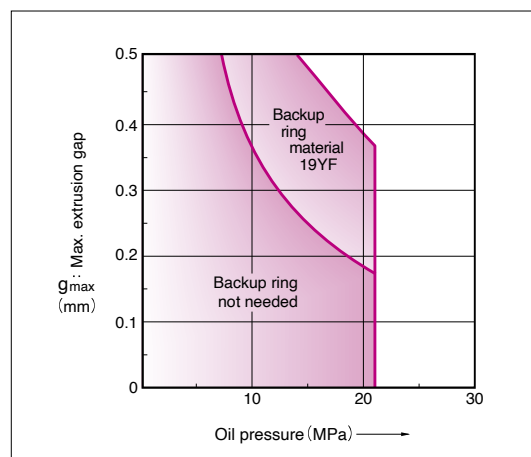

Nominal Size of Packing, and Housing dimensions							Packing Part Number	Combination Backup Ring Part Number
d	D	h	H _A	H _B	ϕD_1	C		BRT2 (Biscut) 19YF
61	71	6	7	10	70	2.5	FU2474S0	GN4629V0
63	73	6	7	10	72	2.5	FU0786S0	GN4814V0
65	75	6	7	10	74	2.5	FU0809S0	GN4816V0
67	77	6	7	10	76	2.5	FU0828S0	GN4697V0
70	80	6	7	10	79	2.5	FU0849S0	GN4651V0
71	80	6	7	10	79	2.5	FU0879S0	GN4818V0
75	85	6	7	10	84	2.5	FU0901S0	GN4692V0
80	90	6	7	10	89	2.5	FU0939S0	GN4820V0
80	95	9	10	13	94	4	FU0942S0	GN5023V0
85	95	6	7	10	94	4	FU2475S0	GN4757V0
85	100	9	10	13	99	4	FU0984S0	GN4687V0
86	100	8.5	9.5	12.5	99	4	FU2476S0	GN4982V1
89	104	9	10	13	103	4	FU2372S0	GN5734V0
90	100	6	7	10	99	4	FU1021S0	GN5735V0
90	105	9	10	13	104	4	FU1024S0	GN4698V0
95	110	9	10	13	109	4	FU1051S0	GN4822V0
96	111	9	10	13	110	4	FU2477S0	GN5736V0
98	112	8.5	9.5	12.5	111	4	FU1067S0	GN4824V0
100	115	9	10	13	113	4	FU1082S0	GN4512V0
105	120	9	10	13	118	4	FU1125S0	GN5198V0
106	120	8.5	9.5	12.5	118	4	FU1135S0	GN4826V0
110	125	9	10	13	123	4	FU1157S0	GN4480V0
112	125	9	10	13	123	4	FU1179S0	GN4827V0
115	130	9	10	13	128	4	FU1195S0	GN4593V0
118	132	8.5	9.5	12.5	130	4	FU1204S0	GN5414V0
125	140	9	10	13	138	4	FU1252S0	GN4481V0
132	145	8.5	9.5	12.5	143	4	FU1291S0	GN5737V0
136	150	8.5	9.5	12.5	148	4	FU1306S0	GN4830V0
145	160	9	10	13	158	4	FU1343S0	GN4551V0

UPH TYPE

PACKINGS FOR BOTH
PISTON AND ROD SEALS
NITRILE RUBBER (NBR)
FLUORORUBBER (FKM)



E
DIMENSION
UPH

- Please designate NOK Part number and type & size on your order.

(Example) Order for the packing as a single piece

· Type Dimensions	UPH	6.3	16.3	7.5
	└─ Type Sign	└─ Nominal Size of Packing described in order of inner diameter(d), outer diameter(D), and height(h)		
· Part Number	CU3308D0			

※ When placing orders for backup rings used in combination with packing, designate the NOK part number and the model size.

· Type Dimensions	BRT3	6.3	16.3	2
	└─ Type Sign	└─ Nominal Size of Backup ring described in order of inner diameter(d), outer diameter(D), and thickness(t)*		
· Part Number	GN0720V0			

*t = H_B-H_A (Housing dimensions)

- Please check the application range on pages 18 and 19 before selecting the type.

Material	Standard : NOK A505 Heat resistant type : NOK F357
-----------------	---

UPH TYPE PACKINGS FOR BOTH PISTON AND ROD SEALS

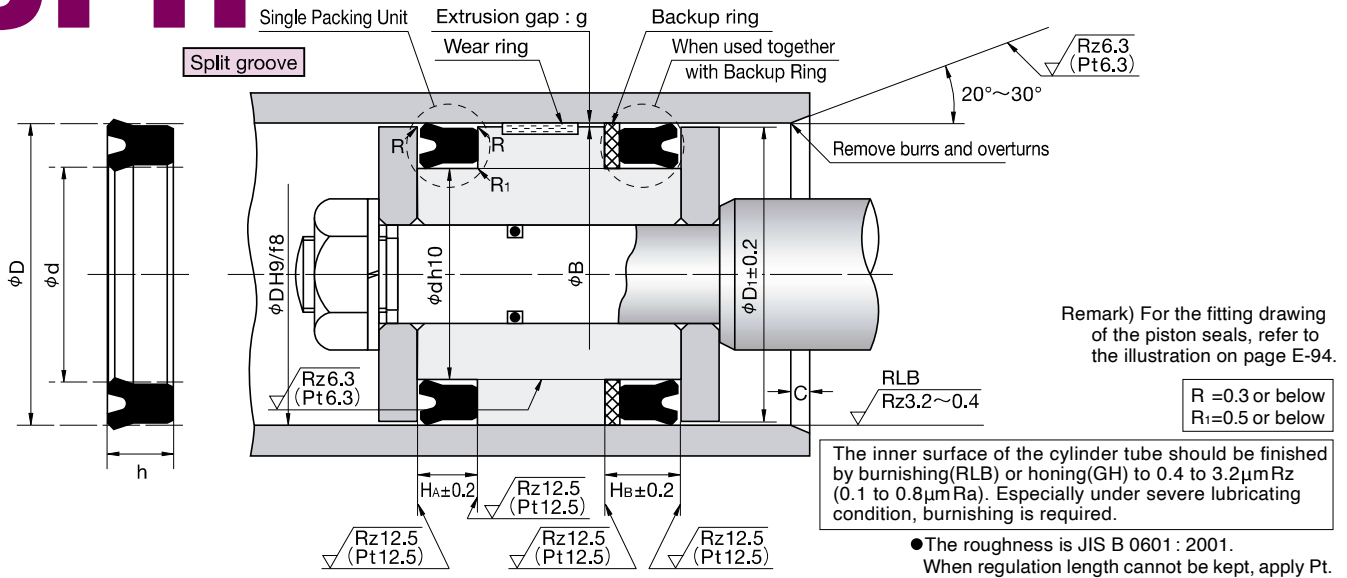

Nominal Size of Packing, and Housing dimensions							Standard (A505)		Heat resistant (F357)		Combination Backup Ring Part Number
d	D	h	HA	HB	φD1	C	Packing Part Number	Nominal Number	Packing Part Number	Nominal Number	BRT3 (Endless)
6.3	16.3	7.5	8.5	10.5	15.3	2.5	CU3308D0	UPH-6.3			GN0720V0
6.3	16.3	8	9	11	15.3	2.5	CU0024D0	UPH-6.3A			GN0720V0
7.1	17.1	7.5	8.5	10.5	16.1	2.5	CU3309D0	UPH-7.1			GN0723V0
7.1	17.1	8	9	11	16.1	2.5	CU0030D0	UPH-7.1A			GN0723V0
8	18	7.5	8.5	10.5	17	2.5	CU0042D0	UPH-8			GN0725V0
8	18	8	9	11	17	2.5	CU0043D1	UPH-8A	CU0043D2	UPH-8AF	GN0725V0
9	19	7.5	8.5	10.5	18	2.5	CU3310D0	UPH-9			GN0728V0
9	19	8	9	11	18	2.5	CU0054D0	UPH-9A			GN0728V0
10	20	7.5	8.5	10.5	19	2.5	CU0068D0	UPH-10			GN0733V0
10	20	8	9	11	19	2.5	CU0069D1	UPH-10A			GN0733V0
11.2	21.2	7.5	8.5	10.5	20.2	2.5	CU3311D0	UPH-11.2			GN0736V0
11.2	21.2	8	9	11	20.2	2.5	CU0081D0	UPH-11.2A			GN0736V0
12	25	8	9	11	24	2.5	CU0093D0	UPH-12	CU0093D3	UPH-12F	GN6005V0
12.5	22.5	7.5	8.5	10.5	21.5	2.5	CU3312D0	UPH-12.5			GN0741V0
12.5	22.5	8	9	11	21.5	2.5	CU0102D0	UPH-12.5A			GN0741V0
14	24	7.5	8.5	10.5	23	2.5	CU0121D0	UPH-14			GN0745V0
14	24	8	9	11	23	2.5	CU0122D0	UPH-14A	CU0122D3	UPH-14AF	GN0745V0
15	25	8	9	11	24	2.5	CU0135D0	UPH-15A			GN0749V0
15	28	10	11	13	27	2.5	CU0137D0	UPH-15			GN6445V0
16	26	7.5	8.5	10.5	25	2.5	CU0156D0	UPH-16	CU0156D2	UPH-16F	GN0751V0
16	26	8	9	11	25	2.5	CU0157D1	UPH-16A			GN0751V0
16	32	10	11	13	31	2.5	CU0161D0	UPH-16B			GN7288V0
18	28	8	9	11	27	2.5	CU0182D0	UPH-18A	CU0182D4	UPH-18AF	GN0757V0
18	31	10	11	13	30	3.5	CU0186D0	UPH-18			GN6446V0
18	33	10	11	13	32	3.5	CU2196D0	UPH-18B			GN7354V0
18.5	31.5	10	11	13	30.5	3.5	CU3313D0	UPH-18.5	CU3313D1	UPH-18.5F	GN7240V0
20	30	8	9	11	29	3.5	CU0215D1	UPH-20A	CU0215D2	UPH-20AF	GN0762V0
20	33	10	11	13	32	3.5	CU0221D0	UPH-20			GN6448V0
20	35	10	11	13	34	3.5	CU0224D0	UPH-20B			GN7289V0
21.5	31.5	8	9	11	30.5	3.5	CU0239D0	UPH-21.5			GN0767V0
22	35	10	11	13	34	3.5	CU0249D0	UPH-22			GN6449V0
22.4	32.4	8	9	11	31.4	3.5	CU0263D0	UPH-22.4A	CU0263D3	UPH-22.4AF	GN0771V0
22.4	35.4	10	11	13	34.4	3.5	CU0265D1	UPH-22.4			GN6017V0
25	35	8	9	11	34	3.5	CU0282D2	UPH-25A	CU0282D3	UPH-25AF	GN0781V0
25	38	10	11	13	37	3.5	CU0288D0	UPH-25			GN6453V0
25	40	10	11	13	39	3.5	CU0292D0	UPH-25B	CU0292D4	UPH-25BF	GN6591V0
25	45	12	13	15	44	3.5	CU0301D0	UPH-25C			GN7291V0
25.5	35.5	8	9	11	34.5	3.5	CU0309D0	UPH-25.5			GN6454V0
27	40	10	11	14	39	3.5	CU2347D0	UPH-27			GN6455V0
28	40	10	11	14	39	3.5	CU0330D2	UPH-28A	CU0330D6	UPH-28AF	GN6457V0
28	41	10	11	14	40	3.5	CU0335D0	UPH-28			GN6458V0
28	43	10	11	14	42	3.5	CU0340D0	UPH-28B			GN0791V0

Remark) The Part number and the one stamped on the product might be different in case of heat resistant type.

HOW TO DETERMINE B DIMENSION

■ When using backup ring

Please determine B dimension according to the table below. If you require smaller B dimension (in case of piston seals) or larger B dimension (in case of rod seals) because of the cylinder configuration, please consult NOK.

Maximum Service Pressure	15MPa	32MPa
Material of Backup ring	19YF	
Dimension	For rod	$B \leq \phi d + 1.0$
	For piston	$B \leq \phi D - 1.0$

■ When not using backup ring

To determine B dimension, please refer to the graph in the right for the maximum extrusion gap (one side) considering the eccentricity of operating condition of the piston or rod.

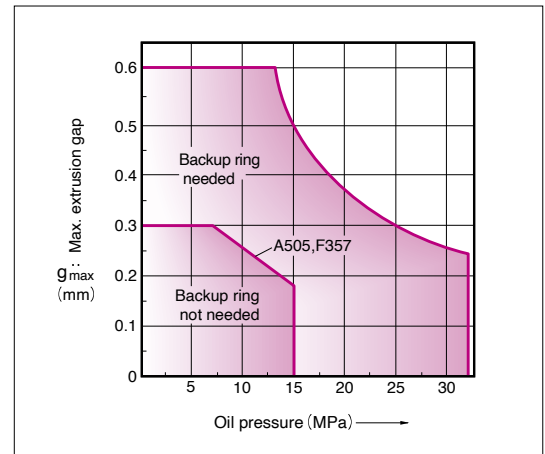

Nominal Size of Packing, and Housing dimensions							Standard (A505)		Heat resistant (F357)		Combination Backup Ring Part Number
d	D	h	H _A	H _B	φD ₁	C	Packing Part Number	Nominal Number	Packing Part Number	Nominal Number	BRT3 (Endless)
30	43	10	11	14	42	3.5	CU0364D0	UPH-30	CU0364D2	UPH-30F	GN6459V0
30	45	10	11	14	44	3.5	CU0368D2	UPH-30A	CU0368D8	UPH-30AF	GN7061V0
31.5	44.5	10	11	14	43.5	3.5	CU0385D0	UPH-31.5			GN6461V0
31.5	46.5	10	11	14	45.5	3.5	CU0387D1	UPH-31.5A			GN0805V0
32	45	10	11	14	44	3.5	CU2451D0	UPH-32			GN7242V0
32	46	10	11	14	45	3.5	CU0403D0	UPH-32A			GN6035V0
32	48	10	11	14	47	3.5	CU0404D0	UPH-32B			GN7356V0
34	50	12	13	16	49	3.5	CU0408D0	UPH-34			GN6462V0
35	50	10	11	14	49	4	CU0437D4	UPH-35B	CU0437D5	UPH-35BF	GN0816V0
35	50	12	13	16	49	4	CU0438D0	UPH-35			GN0816V0
35	51	12	13	16	50	4	CU0441D0	UPH-35A			GN7006V0
35.5	50.5	10	11	14	49.5	4	CU0456D2	UPH-35.5A	CU0456D6	UPH-35.5AF	GN0820V0
35.5	51.5	12	13	16	50.5	4	CU0458D0	UPH-35.5	CU0458D2	UPH-35.5F	GN6330V0
38	52	10	11	14	51	4	CU0470D1	UPH-38			GN6046V0
40	55	10	11	14	54	4	CU0505D3	UPH-40A	CU0505D2	UPH-40AF	GN6759V0
40	56	10	11	14	55	4	CU0508D0	UPH-40B			GN6466V0
40	56	12	13	16	55	4	CU0509D0	UPH-40			GN6466V0
40	60	12	13	16	59	4	CU0514D0	UPH-40C			GN7293V0
41	56	10	11	14	55	4	CU0523D0	UPH-41			GN0835V0
45	60	10	11	14	59	4	CU0577D5	UPH-45A	CU0577D9	UPH-45AF	GN0845V0
45	60	12	13	16	59	4	CU0578D0	UPH-45B			GN0845V0
45	61	12	13	16	60	4	CU0580D0	UPH-45	CU0580D3	UPH-45F	GN6469V0
47	63	12	13	16	62	4	CU0591D0	UPH-47			GN6471V0
48	63	10	11	14	62	4	CU0601D1	UPH-48	CU0601D4	UPH-48F	GN0853V0
50	65	10	11	14	64	4	CU0631D2	UPH-50A	CU0631D7	UPH-50AF	GN6439V0
50	66	12	13	16	65	4	CU0635D0	UPH-50	CU0635D3	UPH-50F	GN6329V0
50	70	12	13	16	69	4	CU0639D3	UPH-50B	CU0639D4	UPH-50BF	GN6592V0
51	71	12	13	16	70	4	CU0669D0	UPH-51			GN0862V0
53	69	12	13	16	68	4	CU3317D0	UPH-53			GN7008V0
53	73	12	13	16	72	4	CU0683D0	UPH-53A			GN0869V0
55	71	12	13	16	70	4	CU0704D1	UPH-55			GN6473V0
55	75	12	13	16	74	4	CU0708D2	UPH-55A	CU0708D6	UPH-55AF	GN7249V0
55	80	15	16	19	79	4	CU0712D0	UPH-55B			GN6072V0
56	72	12	13	16	71	4	CU0727D0	UPH-56	CU0727D2	UPH-56F	GN7009V0
56	76	12	13	16	75	4	CU0728D1	UPH-56A	CU0728D4	UPH-56AF	GN0877V0
60	76	12	13	16	75	4	CU0757D1	UPH-60			GN6476V0
60	80	12	13	16	79	4	CU0761D1	UPH-60A	CU0761D6	UPH-60AF	GN0886V1
63	79	12	13	16	78	4	CU0791D0	UPH-63			GN7010V0
63	83	12	13	16	82	4	CU0793D1	UPH-63A	CU0793D3	UPH-63AF	GN0893V1
64	80	12	13	16	79	4	CU2123D1	UPH-64	CU2123D2	UPH-64F	GN6478V0
65	81	12	13	16	80	5	CU3318D0	UPH-65			GN7011V0
65	85	12	13	16	84	5	CU0819D1	UPH-65A	CU0819D2	UPH-65AF	GN0899V0

Remark) The Part number and the one stamped on the product might be different in case of heat resistant type.

UPH TYPE PACKINGS FOR BOTH PISTON AND ROD SEALS

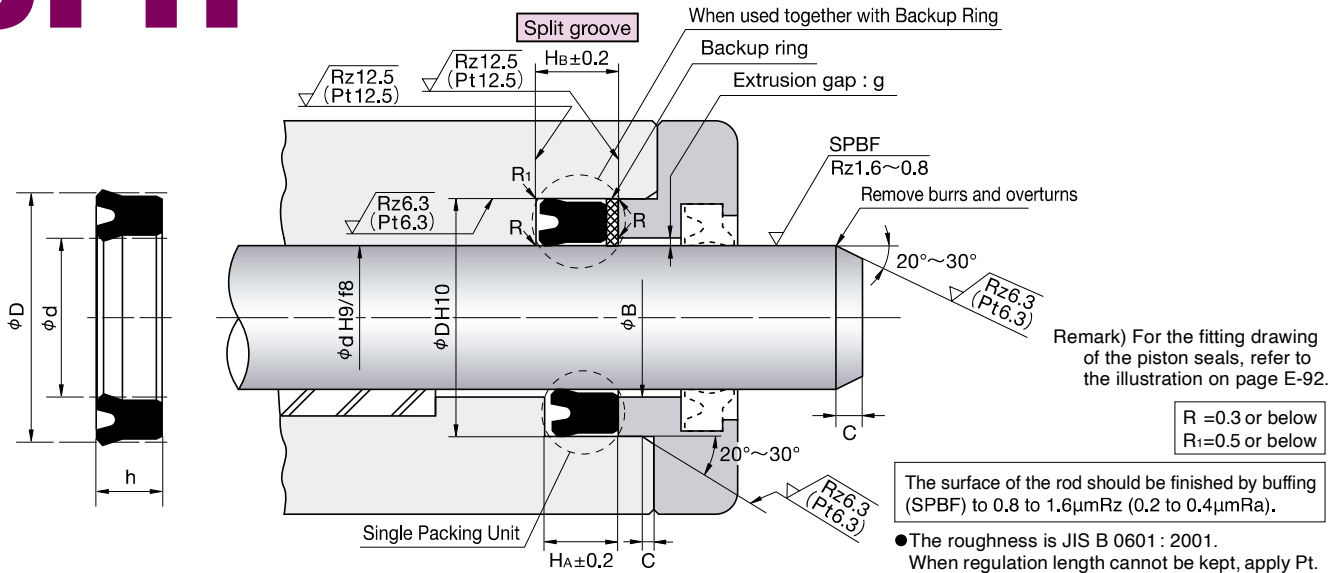

Nominal Size of Packing, and Housing dimensions							Standard (A505)		Heat resistant (F357)		Combination Backup Ring Part Number BRT3 (Endless)
d	D	h	HA	HB	φD1	C	Packing Part Number	Nominal Number	Packing Part Number	Nominal Number	19YF
67	87	12	13	16	86	5	CU0831D0	UPH-67A	CU0831D3	UPH-67AF	GN0904V0
67	87	15	16	19	86	5	CU3319D0	UPH-67			GN0904V0
70	90	12	13	16	89	5	CU0862D1	UPH-70A	CU0862D4	UPH-70AF	GN0910V0
70	90	15	16	19	89	5	CU0864D0	UPH-70	CU0864D2	UPH-70F	GN0910V0
71	91	12	13	16	90	5	CU0884D1	UPH-71A	CU0884D3	UPH-71AF	GN0914V0
71	91	15	16	19	90	5	CU0885D0	UPH-71			GN0914V0
75	95	12	13	16	94	5	CU0910D1	UPH-75A			GN0920V0
75	95	15	16	19	94	5	CU0911D1	UPH-75	CU0911D2	UPH-75F	GN0920V0
80	100	12	13	16	99	5	CU0948D1	UPH-80A	CU0948D9	UPH-80AF	GN0927V0
80	100	15	16	19	99	5	CU0949D2	UPH-80	CU0949D3	UPH-80F	GN0927V0
85	105	12	13	16	104	5	CU0989D1	UPH-85A	CU0989D3	UPH-85AF	GN0932V0
85	105	15	16	19	104	5	CU0990D0	UPH-85			GN0932V0
90	110	12	13	16	109	5	CU1030D3	UPH-90A	CU1030D7	UPH-90AF	GN0939V0
90	110	15	16	19	109	5	CU1031D0	UPH-90	CU1031D3	UPH-90F	GN0939V0
92	112	12	13	16	111	5	CU1042D1	UPH-92A			GN0940V0
92	112	15	16	19	111	5	CU2132D1	UPH-92	CU2132D2	UPH-92F	GN0940V0
95	115	12	13	16	114	5	CU1056D0	UPH-95A	CU1056D4	UPH-95AF	GN0945V0
95	115	15	16	19	114	5	CU1057D1	UPH-95	CU1057D3	UPH-95F	GN0945V0
95	120	15	16	19	118	5	CU1061D0	UPH-95B			GN6716V0
100	120	12	13	16	118	5	CU1089D3	UPH-100A	CU1089D7	UPH-100AF	GN0952V0
100	120	15	16	19	118	5	CU1091D0	UPH-100	CU1091D3	UPH-100F	GN0952V0
100	125	15	16	19	123	5	CU1096D0	UPH-100B	CU1096D3	UPH-100BF	GN7297V0
105	125	15	16	19	123	5	CU1129D2	UPH-105	CU1129D4	UPH-105F	GN0959V0
106	126	15	16	19	124	5	CU1138D0	UPH-106			GN0961V0
110	130	15	16	19	128	5	CU1165D1	UPH-110	CU1165D4	UPH-110F	GN6790V0
112	132	15	16	19	130	5	CU1182D0	UPH-112	CU1182D3	UPH-112F	GN0970V0
115	135	15	16	19	133	5	CU1198D0	UPH-115			GN0974V0
118	138	15	16	19	136	5	CU1207D0	UPH-118	CU1207D2	UPH-118F	GN0978V0
120	140	15	16	19	138	5	CU1224D2	UPH-120	CU1224D1	UPH-120F	GN0982V0
125	145	15	16	19	143	6.5	CU1257D0	UPH-125A			GN0986V0
125	150	19	20	23	148	6.5	CU1933D0	UPH-125	CU1933D2	UPH-125F	GN6135V0
130	150	15	16	19	148	6.5	CU1284D2	UPH-130A	CU1284D4	UPH-130AF	GN6925V0
130	155	19	20	23	153	6.5	CU3320D0	UPH-130			GN7012V0
132	152	15	16	19	150	6.5	CU1292D0	UPH-132A			GN0994V0
132	157	19	20	23	155	6.5	CU2703D1	UPH-132	CU2703D2	UPH-132F	GN7013V0
135	155	15	16	19	153	6.5	CU1305D0	UPH-135B			GN0998V0
135	160	15.7	17	20	158	6.5	CU3322D0	UPH-135A			GN6492V0
135	160	19	20	23	158	6.5	CU1960D0	UPH-135			GN6492V0
140	160	15	16	19	158	6.5	CU1327D1	UPH-140A	CU1327D4	UPH-140AF	GN1002V0
140	165	19	20	23	163	6.5	CU1332D2	UPH-140			GN6494V0
145	165	15	16	19	163	6.5	CU1344D0	UPH-145A			GN1007V0
145	170	19	20	23	168	6.5	CU2348D0	UPH-145	CU2348D1	UPH-145F	GN6496V0

Remark) The Part number and the one stamped on the product might be different in case of heat resistant type.

HOW TO DETERMINE B DIMENSION

■ When using backup ring

Please determine B dimension according to the table below. If you require smaller B dimension (in case of piston seals) or larger B dimension (in case of rod seals) because of the cylinder configuration, please consult NOK.

Maximum Service Pressure	15MPa	32MPa	
Material of Backup ring	19YF		
Dimension	For rod	$B \leq \phi d + 1.0$	$B \leq \phi d + 0.5$
	For piston	$B \geq \phi D - 1.0$	$B \geq \phi D - 0.5$

■ When not using backup ring

To determine B dimension, please refer to the graph in the right for the maximum extrusion gap (one side) considering the eccentricity of operating condition of the piston or rod.

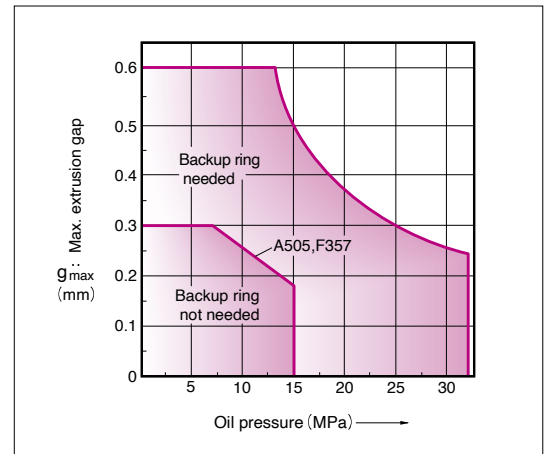

Nominal Size of Packing, and Housing dimensions							Standard (A505)		Heat resistant (F357)		Combination Backup Ring Part Number BRT3 (Endless)
d	D	h	H _A	H _B	φD ₁	C	Packing Part Number	Nominal Number	Packing Part Number	Nominal Number	19YF
150	170	15	16	19	168	6.5	CU1363D2	UPH-150A	CU1363D3	UPH-150AF	GN1011V0
150	175	19	20	23	173	6.5	CU1367D0	UPH-150			GN7014V0
155	180	15	16	20	178	6.5	CU1391D2	UPH-155B	CU1391D4	UPH-155BF	GN1016V0
155	180	15.7	17	21	178	6.5	CU3323D0	UPH-155A			GN1016V0
155	180	19	20	24	178	6.5	CU1393D0	UPH-155			GN1016V0
160	185	15	16	20	183	6.5	CU1413D0	UPH-160A	CU1413D3	UPH-160AF	GN1020V0
160	185	19	20	24	183	6.5	CU2349D0	UPH-160			GN1020V0
165	190	15	16	20	188	6.5	CU1431D0	UPH-165A			GN1023V0
165	190	19	20	24	188	6.5	CU3324D0	UPH-165			GN1023V0
170	195	15	16	20	193	6.5	CU1448D1	UPH-170A	CU1448D3	UPH-170AF	GN1027V0
170	195	19	20	24	193	6.5	CU3325D0	UPH-170			GN1027V0
175	200	15	16	20	198	6.5	CU1461D2	UPH-175B	CU1461D3	UPH-175BF	GN1031V0
175	200	15.7	17	21	198	6.5	CU3326D0	UPH-175A			GN1031V0
175	200	19	20	24	198	6.5	CU1463D1	UPH-175			GN1031V0
180	205	15	16	20	203	6.5	CU1490D0	UPH-180A			GN1035V0
180	205	19	20	24	203	6.5	CU1492D0	UPH-180			GN1035V0
185	210	15	16	20	208	6.5	CU1504D0	UPH-185			GN1039V0
190	215	15	16	20	213	6.5	CU1519D0	UPH-190A	CU1519D2	UPH-190AF	GN1042V0
190	215	19	20	24	213	6.5	CU3327D0	UPH-190			GN1042V0
199	224	15	16	20	222	6.5	CU1532D0	UPH-199B			GN1047V0
199	224	15.7	17	21	222	6.5	CU3329D0	UPH-199A			GN1047V0
199	224	19	20	24	222	6.5	CU1535D0	UPH-199			GN1047V0
200	225	15	16	20	223	6.5	CU1547D0	UPH-200A	CU1547D4	UPH-200AF	GN1050V0
200	225	19	20	24	223	6.5	CU2350D0	UPH-200			GN1050V0
210	235	18	19	23	233	6.5	CU1579D0	UPH-210			GN1057V0
212	237	19	20	24	235	6.5	CU1585D0	UPH-212			GN1058V0
215	240	19	20	24	238	6.5	CU3331D0	UPH-215			GN7256V0
224	249	19	20	24	247	6.5	CU2926D0	UPH-224	CU2926D1	UPH-224F	GN7282V0
225	250	18	19	23	248	6.5	CU1625D0	UPH-225A			GN1065V0
225	250	19	20	24	248	6.5	CU1626D0	UPH-225	CU1626D1	UPH-225F	GN1065V0
236	261	19	20	24	259	6.5	CU1649D1	UPH-236			GN6191V0
250	275	19	20	24	273	6.5	CU1683D1	UPH-250			GN1078V0
255	280	19	20	24	278	8	CU1694D0	UPH-255	CU1694D3	UPH-255F	GN6513V0
265	297	24	26	30	295	8	CU1714D0	UPH-265			GN6515V0
270	300	18	19	23	298	8	CU1722D0	UPH-270A			GN1089V0
270	300	24	26	30	298	8	CU1725D0	UPH-270	CU1725D1	UPH-270F	GN1089V0
280	310	22	24	28	308	8	CU2774D0	UPH-280A			GN1093V0
280	312	24	26	30	310	8	CU2166D0	UPH-280	CU2166D1	UPH-280F	GN6519V0
283	315	24	26	30	313	8	CU1918D0	UPH-283			GN7358V0
290	320	18	19	23	318	8	CU1750D0	UPH-290A			GN1098V0
290	320	22	24	28	318	8	CU1752D0	UPH-290			GN1098V0
300	332	24	26	30	330	8	CU2351D0	UPH-300			GN6522V0

Remark) The Part number and the one stamped on the product might be different in case of heat resistant type.

UPH^{TYPE} PACKINGS FOR BOTH PISTON AND ROD SEALS

[Large size dimension table]

■ When using packings on this large size, please consult NOK.

Nominal Size of Packing, and Housing dimensions							Standard (A505)		Heat resistant (F357)		Combination Backup Ring Part Number BRT3 (Endless)
d	D	h	H _A	H _B	φD ₁	C	Packing Part Number	Nominal Number	Packing Part Number	Nominal Number	19YF
310	340	18	19	23	338	10	CU1772D0	UPH-310A			
310	340	22	24	28	338	10	CU1773D0	UPH-310	CU1773D2	UPH-310F	
315	347	24	26	30	345	10	CU3064D0	UPH-315			
320	340	12	13	17	338	10	CU2101D0	UPH-320A			
320	350	22	24	28	348	10	CU1780D0	UPH-320			
323	355	24	26	30	353	10	CU1784D0	UPH-323			
330	355	16	17	21	353	10	CU1786D0	UPH-330A			
330	356	20	22	26	354	10	CU1787D0	UPH-330B			
330	360	22	24	28	358	10	CU1789D0	UPH-330			
335	355	14	15	19	353	10	CU1793D1	UPH-335A			
335	367	24	26	30	365	10	CU2197D0	UPH-335			
340	370	22	24	28	368	10	CU1795D0	UPH-340			
345	365	14	15	19	363	10	CU2243D0	UPH-345			
348	380	24	26	30	378	10	CU2087D1	UPH-348			
350	370	14	15	19	368	10	CU2302D0	UPH-350A			
350	380	22	24	28	378	10	CU1799D2	UPH-350			
355	385	22	24	28	383	10	CU1801D0	UPH-355A			
355	387	24	26	30	385	10	CU1916D0	UPH-355			
360	390	22	24	28	388	10	CU1803D0	UPH-360	CU1803D2	UPH-360F	
365	395	22	24	28	393	10	CU1805D0	UPH-365			
368	400	24	26	30	398	10	CU1807D0	UPH-368	CU1807D1	UPH-368F	
370	400	23	25	29	398	10	CU1810D0	UPH-370A			
370	400	25	27	31	398	10	CU1811D0	UPH-370			
371	396	16	17	21	394	10	CU2303D0	UPH-371			
375	407	24	26	30	405	10	CU3357D0	UPH-375			
380	400	15	16	20	398	10	CU1813D0	UPH-380A			
380	410	15	16	20	408	10	CU1815D0	UPH-380B			
380	420	30	32	36	418	10	CU2162D0	UPH-380			
390	420	22	24	28	418	10	CU1818D0	UPH-390			
395	425	22	24	28	423	10	CU1819D0	UPH-395			
400	430	22	24	28	428	10	CU1823D0	UPH-400A			
400	430	25	27	31	428	10	CU2007D0	UPH-400B			
400	432	24	26	30	430	10	CU3358D0	UPH-400			

Remark 1) When using packings on this large size, please consult NOK.

Remark 2) When placing orders for the backup ring on this large size, please consult NOK.

Remark 3) The Part number and the one stamped on the product might be different in case of heat resistant type.

Nominal Size of Packing, and Housing dimensions							Standard (A505)		Heat resistant (F357)		Combination Backup Ring Part Number
d	D	h	H _A	H _B	φD ₁	C	Packing Part Number	Nominal Number	Packing Part Number	Nominal Number	BRT3(Endless)
											19YF
420	455	25	27	32	453	10	CU1833D0	UPH-420			
425	457	24	26	31	455	10	CU1917D0	UPH-425			
430	470	20	22	27	468	10	CU1837D0	UPH-430			
435	470	25	27	32	468	10	CU1841D0	UPH-435			
440	480	35	37	42	478	10	CU1843D0	UPH-440			
445	470	18	19	24	468	10	CU2244D0	UPH-445			
450	480	22	24	29	478	10	CU1844D0	UPH-450A			
450	482	24	26	31	480	10	CU3359D0	UPH-450			
460	500	20	22	27	498	10	CU1850D0	UPH-460			
475	507	24	26	31	505	10	CU1853D0	UPH-475			
480	505	18	19	24	503	10	CU2245D0	UPH-480A			
490	530	25	27	32	528	10	CU1855D0	UPH-490			
520	550	17	18	23	548	10	CU2189D0	UPH-520A			
525	555	15	16	21	553	10	CU1860D0	UPH-525			
530	570	20	22	27	568	10	CU2084D0	UPH-530A			
540	560	14	15	20	558	10	CU2037D0	UPH-540			
570	600	17	18	23	598	10	CU2190D0	UPH-570A			
600	630	20	22	27	628	10	CU2160D0	UPH-600A			
600	630	28	30	35	628	10	CU2036D0	UPH-600B			
600	640	30	32	37	638	10	CU1868D0	UPH-600			
640	685	25	27	32	683	12	CU2284D0	UPH-640			
700	730	15	16	21	728	12	CU1873D0	UPH-700A			
760	800	34	36	41	798	12	CU1877D0	UPH-760			
768	800	30	32	37	798	12	CU1878D0	UPH-768			
818	850	24	26	31	848	12	CU1882D1	UPH-818			
825	850	15.5	16.5	21.5	848	12	CU1883D0	UPH-825A			
825	860	27	29	34	858	12	CU2124D0	UPH-825			
925	950	14	15	20	948	12	CU2325D0	UPH-925			
950	980	20	22	27	978	12	CU1892D0	UPH-950			
1020	1050	18	19	24	1048	12	CU1894D0	UPH-1020A			
1025	1055	15	16	21	1053	12	CU1895D0	UPH-1025			
1100	1140	20	22	27	1138	12	CU2192D0	UPH-1100			
1220	1280	30	32	37	1278	12	CU1899D0	UPH-1220			
1560	1600	20	22	27	1598	12	CU2191D0	UPH-1560			
1620	1680	30	32	37	1678	12	CU1904D0	UPH-1620			

Remark 1) When using packings on this large size, please consult NOK.

Remark 2) When placing orders for the backup ring on this large size, please consult NOK.

Remark 3) The Part number and the one stamped on the product might be different in case of heat resistant type.

USH TYPE

PACKINGS FOR BOTH
PISTON AND ROD SEALS
NITRILE RUBBER (NBR)
FLUORORUBBER (FKM)



● Please designate NOK Part number and type & size on your order.

(Example) Order for the packing as a single piece

· Type Dimensions	USH	12	20	5	
	└─ Type Sign	└─ Nominal Size of Packing described in order of inner diameter(d), outer diameter(D), and height(h)			
· Part Number	CU3248K0				

※ When placing orders for backup rings used in combination with packing, designate the NOK part number and the model size.

· Type Dimensions	BRT2	12	20	2	
	└─ Type Sign	└─ Nominal Size of Backup ring described in order of inner diameter(d), outer diameter(D), and thickness(t)*			
· Part Number	GN5723V0				*t = H _B -H _A (Housing dimensions)

● Please check the application range on pages 18 and 19 before selecting the type.

Material	Standard : NOK A505 Heat resistant type : NOK F357
-----------------	---

USH TYPE

PACKINGS FOR BOTH PISTON AND ROD SEALS (INSTALLED WITH INTERNAL GROOVE)

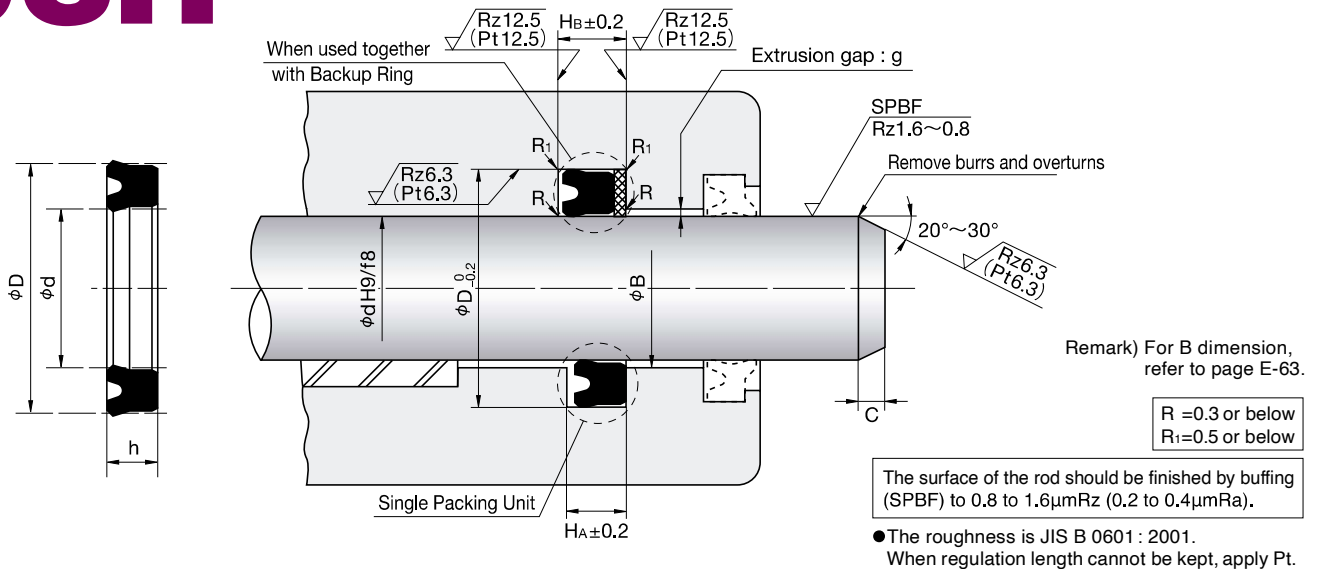

Nominal Size of Packing, and Housing dimensions							Standard (A505)		Heat resistant (F357)		Combination Backup Ring Part Number
d	D	h	H _A	H _B	φD ₁	C	Packing Part Number	Nominal Number	Packing Part Number	Nominal Number	BRT2 (Biascut)
12	20	5	5.7	7.7	19	2	● CU3248K0	USH-12			GN5723V0
14	22	5	5.7	7.7	21	2	● CU2692K0	USH-14			GN5719V0
16	24	5	5.7	7.7	23	2	● CU2548K0	USH-16	● CU2548K2	USH-16F	GN5720V0
18	26	5	5.7	7.7	25	2	CU0180K0	USH-18	CU0180K6	USH-18F	GN4778V0
20	28	5	5.7	7.7	27	2	CU0212K0	USH-20	CU0212K4	USH-20F	GN4780V0
22	30	5	5.7	7.7	29	2	CU3017K0	USH-22	CU3017K3	USH-22F	GN5726V0
22.4	30	5	5.7	7.7	29	2	CU0260K0	USH-22.4	CU0260K3	USH-22.4F	GN4784V0
23.5	31.5	5	5.7	7.7	30.5	2	CU0267K0	USH-23.5			GN4786V0
24	32	5	5.7	7.7	31	2	CU2971K0	USH-24	CU2971K1	USH-24F	GN5727V0
25	33	5	5.7	7.7	32	2.5	CU0276K0	USH-25	CU0276K3	USH-25F	GN5019V1
27	35	5	5.7	8.7	34	2.5	CU3187K0	USH-27			GN5707V0
28	35.5	5	5.7	8.7	34.5	2.5	CU0320K0	USH-28	CU0320K2	USH-28F	GN4791V0
28	36	5	5.7	8.7	35	2.5	CU2536K0	USH-28A			GN5715V0
30	40	6	7	10	39	2.5	CU0357K0	USH-30	CU0357K6	USH-30F	GN4794V0
31.5	41.5	6	7	10	40.5	2.5	CU0382K0	USH-31.5	CU0382K1	USH-31.5F	GN4796V0
32	42	6	7	10	41	2.5	CU2819K0	USH-32			GN5730V0
35	45	6	7	10	44	2.5	CU0424K0	USH-35	CU0424K3	USH-35F	GN4799V0
35.5	45	6	7	10	44	2.5	CU0451K0	USH-35.5	CU0451K1	USH-35.5F	GN4801V0
35.5	45.5	6	7	10	44.5	2.5	CU3253K0	USH-35.5A			GN5716V0
36	46	6	7	10	45	2.5	CU3040K1	USH-36			GN5733V0
40	50	6	7	10	49	2.5	CU0497K0	USH-40	CU0497K3	USH-40F	GN4050V0
45	55	6	7	10	54	2.5	CU0567K0	USH-45	CU0567K4	USH-45F	GN4804V0
45	56	7	8	11	55	2.5	CU0572K0	USH-45A	CU0572K1	USH-45AF	GN4805V0
50	60	6	7	10	59	2.5	CU0619K0	USH-50	CU0619K4	USH-50F	GN4335V0
53	63	6	7	10	62	2.5	CU0679K0	USH-53	CU0679K4	USH-53F	GN4693V0
55	65	6	7	10	64	2.5	CU0694K0	USH-55			GN4810V0
56	66	6	7	10	65	2.5	CU0722K0	USH-56	CU0722K2	USH-56F	GN4766V0
58	68	6	7	10	67	2.5	CU3255K0	USH-58			GN5641V0
60	70	6	7	10	69	2.5	CU0746K0	USH-60	CU0746K3	USH-60F	GN4676V0
60	71	7	8	11	70	2.5	CU0750K0	USH-60A			GN4812V0
63	73	6	7	10	72	2.5	CU0786K0	USH-63	CU0786K2	USH-63F	GN4814V0
65	75	6	7	10	74	2.5	CU0809K0	USH-65	CU0809K2	USH-65F	GN4816V0
67	77	6	7	10	76	2.5	CU0828K0	USH-67	CU0828K1	USH-67F	GN4697V0
70	80	6	7	10	79	2.5	CU0849K0	USH-70	CU0849K4	USH-70F	GN4651V0
71	80	6	7	10	79	2.5	CU0879K0	USH-71	CU0879K1	USH-71F	GN4818V0
75	85	6	7	10	84	2.5	CU0901K0	USH-75			GN4692V0
80	90	6	7	10	89	2.5	CU0939K0	USH-80	CU0939K3	USH-80F	GN4820V0
85	95	6	7	10	94	4	CU1959K0	USH-85A			GN4757V0
85	100	9	10	13	98	4	CU0984K0	USH-85	CU0984K4	USH-85F	GN4687V0
90	100	6	7	10	99	4	CU1021K0	USH-90A			GN5735V0
90	105	9	10	13	103	4	CU1024K0	USH-90	CU1024K4	USH-90F	GN4698V0
95	110	9	10	13	108	4	CU1051K0	USH-95	CU1051K3	USH-95F	GN4822V0

Remark 1) When using the packing with ●, provide separate grooves.

Remark 2) The Part number and the one stamped on the product might be different in case of heat resistant type.

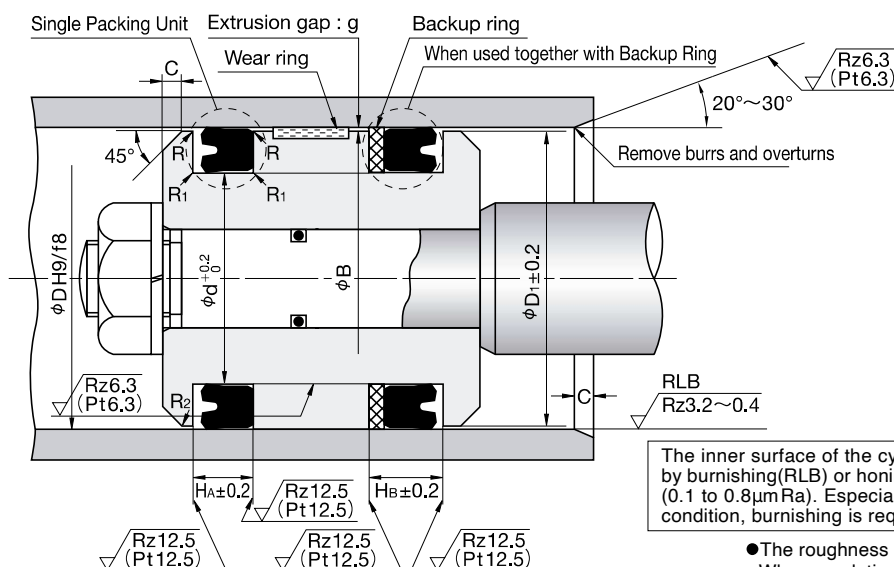

Nominal Size of Packing, and Housing dimensions							Standard (A505)		Heat resistant (F357)		Combination Backup Ring Part Number BRT2 (Biascut)
d	D	h	H _A	H _B	φD ₁	C	Packing Part Number	Nominal Number	Packing Part Number	Nominal Number	19YF
98	112	8.5	9.5	12.5	110	4	CU1067K0	USH-98	CU1067K2	USH-98F	GN4824V0
100	115	9	10	13	113	4	CU1082K0	USH-100	CU1082K3	USH-100F	GN4512V0
106	120	8.5	9.5	12.5	118	4	CU1135K0	USH-106	CU1135K1	USH-106F	GN4826V0
110	125	9	10	13	123	4	CU1157K0	USH-110			GN4480V0
112	125	8.5	9.5	12.5	123	4	CU1178K0	USH-112	CU1178K1	USH-112F	GN4827V0
112	125	9	10	13	123	4	CU1179K0	USH-112A			GN4827V0
115	130	8.5	9.5	12.5	128	4	CU3259K0	USH-115			GN4593V0
118	132	8.5	9.5	12.5	130	4	CU1204K0	USH-118			GN5414V0
125	140	9	10	13	138	4	CU1252K0	USH-125	CU1252K2	USH-125F	GN4481V0
130	145	9	10	13	143	4	CU1280K0	USH-130			GN4628V1
132	145	8.5	9.5	12.5	143	4	CU1291K0	USH-132			GN5737V0
136	150	8.5	9.5	12.5	148	4	CU1306K0	USH-136	CU1306K3	USH-136F	GN4830V0
140	155	9	10	13	153	4	CU1323K0	USH-140	CU1323K1	USH-140F	GN4526V0
145	160	9	10	13	158	4	CU1343K0	USH-145	CU1343K2	USH-145F	GN4551V0
150	165	9	10	13	163	4	CU1359K0	USH-150	CU1359K1	USH-150F	GN4833V0
155	170	9	10	14	168	4	CU3261K0	USH-155			GN4834V0
160	175	9	10	14	173	4	CU1406K0	USH-160	CU1406K2	USH-160F	GN4835V0
165	180	9	10	14	178	4	CU1429K0	USH-165	CU1429K2	USH-165F	GN4836V0
170	185	9	10	14	183	4	CU3262K0	USH-170			GN5464V0
175	190	9	10	14	188	4	CU3038K0	USH-175			GN4839V0
180	200	12	13	17	198	5	CU1483K0	USH-180	CU1483K2	USH-180F	GN4470V0
190	210	12	13	17	208	5	CU2516K0	USH-190	CU2516K1	USH-190F	GN4841V0
195	215	12	13	17	213	5	CU3263K0	USH-195			GN5746V0
200	220	12	13	17	218	5	CU1543K0	USH-200	CU1543K1	USH-200F	GN4385V0
204	224	12	13	17	222	5	CU1563K0	USH-204	CU1563K1	USH-204F	GN4842V0
220	240	12	13	17	238	5	CU1596K0	USH-220			GN4444V0
224	244	12	13	17	242	5	CU1609K0	USH-224			GN5132V0
230	250	12	13	17	248	5	CU1637K0	USH-230	CU1637K1	USH-230F	GN4635V0
240	260	12	13	17	258	5	CU1657K0	USH-240			GN4845V0
250	270	12	13	17	268	5	CU1678K0	USH-250			GN4459V0
260	280	14	15	19	278	5	CU1702K0	USH-260	CU1702K1	USH-260F	GN5563V0
280	300	14	15	19	298	5	CU1962K0	USH-280			GN5459V0
295	315	14	15	19	313	5	CU1756K0	USH-295			GN5738V0
300	320	12	13	17	318	5	CU3267K0	USH-300			GN5581V0
335	355	14	15	19	353	5	CU1793K0	USH-335			
355	375	14	15	19	373	5	CU3270K0	USH-355			
380	400	14	15	19	398	5	CU2002K0	USH-380			
400	420	14	15	19	418	5	CU3271K0	USH-400			
450	470	14	15	20	468	5	CU3273K0	USH-450			
500	525	17	18	23	523	6.5	CU3275K0	USH-500			

Remark 1) When using packings on this large size, please consult NOK.

Remark 2) The Part number and the one stamped on the product might be different in case of heat resistant type.

Remark 3) When placing orders for the backup ring on this large size, please consult NOK.

V99F TYPE

PACKINGS FOR BOTH PISTON AND ROD SEALS FABRIC REINFORCED NITRILE RUBBER



E
DIMENSION
V99F

● Please designate NOK Part number and type & size on your order.

(1) In case of V packing only

VP F 6.3 CV0002C0
 └─ V packing └─ Nominal number └─ Part Number

(2) In case of adapter

VM1- 6.3 CP3673A0
 └─ Nominal Number └─ Part Number

(3) In case of the combination of
V packing and adapter
(In this case, the part number does
not need to be designated.)

VPF 6.3 - 3 1 1
 └─ V packing └─ Nominal number └─ Number of V packings in use └─ Type of male adapter └─ Type of female adapter
 1...fabric reinforced nitrile rubber 1...fabric reinforced nitrile rubber
 2...equivalent to BC3 2...equivalent to BC3

● Please check the application range on pages 18 and 19 before selecting the type.

Material	V packing only	NOK 21AG (fabric reinforced nitrile rubber)																		
	Adapter	Type 1 : NOK 21AG (fabric reinforced nitrile rubber) Type 2 : equivalent to BC3 (bronze)																		
Caution for application	1. Initial tightening torque After fitting into the groove, adjust the tightening torque by using shims according to the below instruction. These figures do not mean the final tightening torque. Initial tightening torque (reference value) (mm)																			
	<table border="1"> <thead> <tr> <th rowspan="2">Nominal number</th> <th colspan="3">Number of packings</th> </tr> <tr> <th>3</th> <th>4</th> <th>5</th> </tr> </thead> <tbody> <tr> <td>F6.3 ~ 250</td> <td>0.45</td> <td>0.60</td> <td>0.75</td> </tr> <tr> <td>F265 ~ 500</td> <td>0.75</td> <td>1.00</td> <td>1.25</td> </tr> <tr> <td>F530 ~ 650</td> <td>1.20</td> <td>1.60</td> <td>2.00</td> </tr> </tbody> </table>		Nominal number	Number of packings			3	4	5	F6.3 ~ 250	0.45	0.60	0.75	F265 ~ 500	0.75	1.00	1.25	F530 ~ 650	1.20	1.60
Nominal number	Number of packings																			
	3	4	5																	
F6.3 ~ 250	0.45	0.60	0.75																	
F265 ~ 500	0.75	1.00	1.25																	
F530 ~ 650	1.20	1.60	2.00																	
	2. About the material of adapter If the operation pressure exceeds 8MPa, use the material of BC equivalent.																			

V99F TYPE PACKINGS FOR BOTH PISTON AND ROD SEALS (EQUIVALENT TO JIS B 2403)

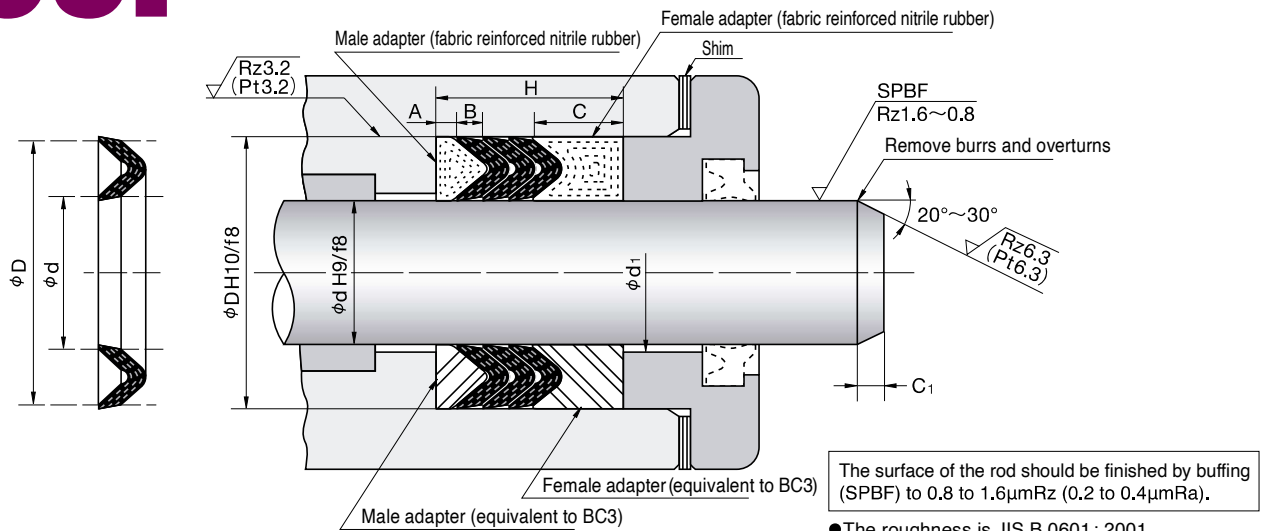

●The roughness is JIS B 0601 : 2001.
When regulation length cannot be kept, apply Pt.

Nominal Number	Nominal Size of Packing			NOK Part Number	Adapter size		Installation length H			C ₁	φd ₁	φD ₁
	d	D	B ^{+0.5} _{-0.2}		A	C	Number of packings					
F 6.3	6.3	16.3	3	CV0002C0	3	5	17	20	23	2	d+1	D-1
F 7.1	7.1	17.1	3	CV0006C0	3	5	17	20	23	2.5	d+1	D-1
F 8	8	18	3	CV0011C0	3	5	17	20	23	2.5	d+1	D-1
F 9	9	19	3	CV0019C0	3	5	17	20	23	2.5	d+1	D-1
F 10	10	20	3	CV0028C0	3	5	17	20	23	2.5	d+1	D-1
F 11.2	11.2	21.2	3	CV0038C0	3	5	17	20	23	2.5	d+1	D-1
F 12.5	12.5	22.5	3	CV0047C0	3	5	17	20	23	2.5	d+1	D-1
F 14	14	24	3	CV0057C0	3	5	17	20	23	2.5	d+1	D-1
F 16	16	26	3	CV0085C0	3	5	17	20	23	2.5	d+1	D-1
F 15	15	28	3	CV0071C0	3	6.5	18.5	21.5	24.5	3.5	d+1	D-1
F 18	18	31	3	CV0109C0	3	6.5	18.5	21.5	24.5	3.5	d+1	D-1
F 18.5	18.5	31.5	3	CV0114C0	3	6.5	18.5	21.5	24.5	3.5	d+1	D-1
F 20	20	33	3	CV0132C0	3	6.5	18.5	21.5	24.5	3.5	d+1	D-1
F 22.4	22.4	35.4	3	CV0163C0	3	6.5	18.5	21.5	24.5	3.5	d+1	D-1
F 25	25	38	3	CV0176C0	3	6.5	18.5	21.5	24.5	3.5	d+1	D-1
F 27	27	40	3	CV0220C0	3	6.5	18.5	21.5	24.5	3.5	d+1	D-1
F 28	28	41	3	CV0231C0	3	6.5	18.5	21.5	24.5	3.5	d+1	D-1
F 31.5	31.5	44.5	3	CV0280C0	3	6.5	18.5	21.5	24.5	3.5	d+1	D-1
F 32	32	45	3	CV0293C0	3	6.5	18.5	21.5	24.5	3.5	d+1	D-1
F 34	34	50	4	CV0309C0	3	8	23	27	31	4	d+1	D-1
F 35.5	35.5	51.5	4	CV0339C0	3	8	23	27	31	4	d+1	D-1
F 40	40	56	4	CV0370C0	3	8	23	27	31	4	d+1	D-1
F 45	45	61	4	CV0418C0	3	8	23	27	31	4	d+1	D-1
F 47	47	63	4	CV0441C0	3	8	23	27	31	4	d+1	D-1
F 50	50	66	4	CV0457C0	3	8	23	27	31	4	d+1	D-1
F 53	53	69	4	CV0503C0	3	8	23	27	31	4	d+1	D-1
F 55	55	71	4	CV0518C0	3	8	23	27	31	4	d+1	D-1
F 56	56	72	4	CV0539C0	3	8	23	27	31	4	d+1	D-1
F 60	60	76	4	CV0562C0	3	8	23	27	31	4	d+1	D-1
F 63	63	79	4	CV0599C0	3	8	23	27	31	4	d+1	D-1
F 64	64	80	4	CV0620C0	3	8	23	27	31	4	d+1	D-1
F 67	67	87	5	CV0651C0	3	10	28	33	38	5	d+1	D-2
F 70	70	90	5	CV0674C0	3	10	28	33	38	5	d+1	D-2
F 71	71	91	5	CV0701C0	3	10	28	33	38	5	d+1	D-2
F 75	75	95	5	CV0711C0	3	10	28	33	38	5	d+1	D-2
F 80	80	100	5	CV0755C0	3	10	28	33	38	5	d+1	D-2
F 85	85	105	5	CV0793C0	3	10	28	33	38	5	d+2	D-2
F 90	90	110	5	CV0827C0	3	10	28	33	38	5	d+2	D-2
F 92	92	112	5	CV0850C0	3	10	28	33	38	5	d+2	D-2
F 95	95	115	5	CV0855C0	3	10	28	33	38	5	d+2	D-2
F 100	100	120	5	CV0873Y0	3	10	28	33	38	5	d+2	D-2
F 105	105	125	5	CV0928C0	3	10	28	33	38	5	d+2	D-2
F 106	106	126	5	CV0940C0	3	10	28	33	38	5	d+2	D-2
F 112	112	132	5	CV0967C0	3	10	28	33	38	5	d+2	D-2

E DIMENSION V99F

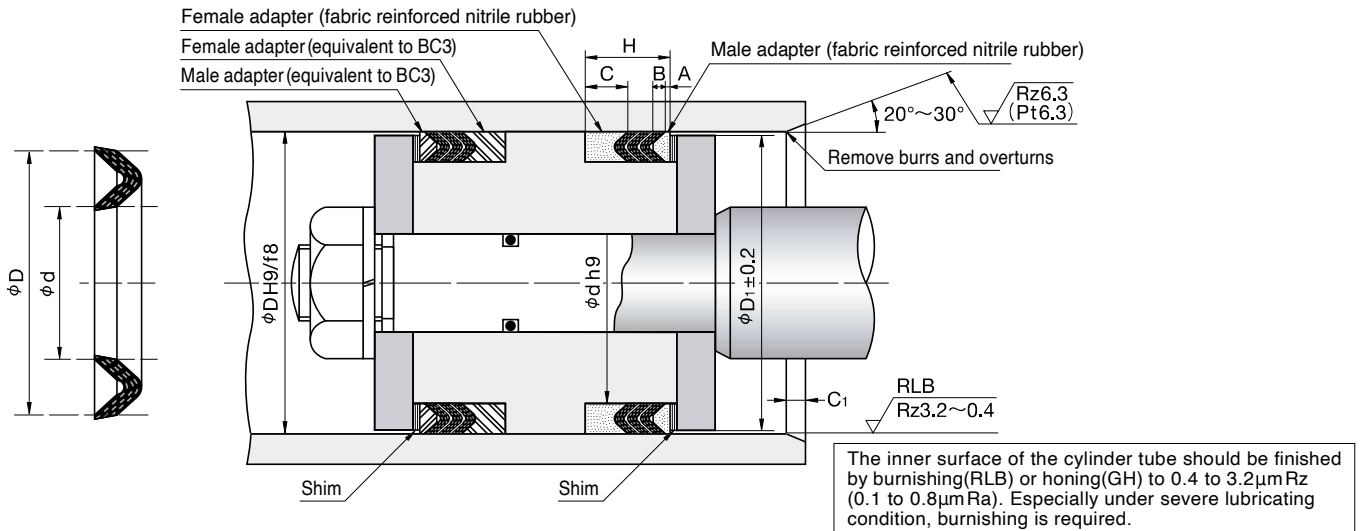

●The roughness is JIS B 0601 : 2001.
When regulation length cannot be kept, apply Pt.

Fabric reinforced nitrile rubber adapter				Metal (equivalent to BC3) adapter			
Male		Female		Male		Female	
Nominal Number	NOK Part Number	Nominal Number	NOK Part Number	Nominal Number	NOK Part Number	Nominal Number	NOK Part Number
VM1- 6.3	CP3673A0	VF1- 6.3	CP0839A0	VM2- 6.3	CP3673B0	VF2- 6.3	CP0840B0
VM1- 7.1	CP3044A0	VF1- 7.1	CP0051A0	VM2- 7.1	CP3044B0	VF2- 7.1	CP0841B0
VM1- 8	CP3081A0	VF1- 8	CP0775A0	VM2- 8	CP3081B0	VF2- 8	CP0091B0
VM1- 9	CP3646A0	VF1- 9	CP0842A0	VM2- 9	CP3646B0	VF2- 9	CP0776B0
VM1- 10	CP3080A0	VF1- 10	CP0777A0	VM2- 10	CP3080B0	VF2- 10	CP0778B0
VM1- 11.2	CP3674A0	VF1- 11.2	CP0843A0	VM2- 11.2	CP3674B0	VF2- 11.2	CP0844B0
VM1- 12.5	CP3077A0	VF1- 12.5	CP0821A0	VM2- 12.5	CP3077B0	VF2- 12.5	CP0086B0
VM1- 14	CP3055A0	VF1- 14	CP0063A0	VM2- 14	CP3055B0	VF2- 14	CP0779B0
VM1- 16	CP3247A0	VF1- 16	CP0780A0	VM2- 16	CP3247B1	VF2- 16	CP0781B0
VM1- 15	CP3082A0	VF1- 15	CP0092A0	VM2- 15	CP3082B0	VF2- 15	CP0093B0
VM1- 18	CP3115A0	VF1- 18	CP0782A0	VM2- 18	CP3115B0	VF2- 18	CP0137B0
VM1- 18.5	CP3647A0	VF1- 18.5	CP0845A0	VM2- 18.5	CP3647B0	VF2- 18.5	CP0783B0
VM1- 20	CP3056A0	VF1- 20	CP0064A0	VM2- 20	CP3056B0	VF2- 20	CP0094B0
VM1- 22.4	CP3083A0	VF1- 22.4	CP0095A0	VM2- 22.4	CP3083B0	VF2- 22.4	CP0784B0
VM1- 25	CP3084A0	VF1- 25	CP0097A0	VM2- 25	CP3084B0	VF2- 25	CP0096B0
VM1- 27	CP3648A0	VF1- 27	CP0785A0	VM2- 27	CP3648B0	VF2- 27	CP0786B0
VM1- 28	CP3070A0	VF1- 28	CP0098A0	VM2- 28	CP3070B0	VF2- 28	CP0079B0
VM1- 31.5	CP3053A0	VF1- 31.5	CP0787A0	VM2- 31.5	CP3053B0	VF2- 31.5	CP0061B0
VM1- 32	CP3078A0	VF1- 32	CP0099A0	VM2- 32	CP3078B0	VF2- 32	CP0087B0
VM1- 34	CP3085A0	VF1- 34	CP0100A0	VM2- 34	CP3085B0	VF2- 34	CP0100B0
VM1- 35.5	CP3649A0	VF1- 35.5	CP0788A0	VM2- 35.5	CP3649B0	VF2- 35.5	CP0788B0
VM1- 40	CP3060A0	VF1- 40	CP0101A0	VM2- 40	CP3060B0	VF2- 40	CP0101B0
VM1- 45	CP3086A0	VF1- 45	CP0102A0	VM2- 45	CP3086B0	VF2- 45	CP0102B0
VM1- 47	CP3650A0	VF1- 47	CP0199A0	VM2- 47	CP3650B0	VF2- 47	CP0199B0
VM1- 50	CP3064A0	VF1- 50	CP0072A0	VM2- 50	CP3064B0	VF2- 50	CP0072B0
VM1- 53	CP3087A0	VF1- 53	CP0103A0	VM2- 53	CP3087B0	VF2- 53	CP0103B0
VM1- 55	CP3651A0	VF1- 55	CP0789A0	VM2- 55	CP3651B0	VF2- 55	CP0789B0
VM1- 56	CP3652A0	VF1- 56	CP0790A0	VM2- 56	CP3652B0	VF2- 56	CP0790B0
VM1- 60	CP3088A0	VF1- 60	CP0104A0	VM2- 60	CP3088B0	VF2- 60	CP0104B0
VM1- 63	CP3089A0	VF1- 63	CP0105A0	VM2- 63	CP3089B0	VF2- 63	CP0105B0
VM1- 64	CP3059A0	VF1- 64	CP0067A0	VM2- 64	CP3090B0	VF2- 64	CP0106B0
VM1- 67	CP3091A0	VF1- 67	CP0107A0	VM2- 67	CP3091B0	VF2- 67	CP0791B0
VM1- 70	CP3051A0	VF1- 70	CP0029A1	VM2- 70	CP3051B0	VF2- 70	CP0059B0
VM1- 71	CP3653A0	VF1- 71	CP0792A0	VM2- 71	CP3653B0	VF2- 71	CP0793B0
VM1- 75	CP3092A0	VF1- 75	CP0109A0	VM2- 75	CP3092B0	VF2- 75	CP0108B0
VM1- 80	CP3007A0	VF1- 80	CP0055A0	VM2- 80	CP3093B0	VF2- 80	CP0009B1
VM1- 85	CP3094A0	VF1- 85	CP0110A0	VM2- 85	CP3094B0	VF2- 85	CP0794B0
VM1- 90	CP3095A0	VF1- 90	CP0111A0	VM2- 90	CP3095B0	VF2- 90	CP0313B0
VM1- 92	CP3675A0	VF1- 92	CP0846A0	VM2- 92	CP3675B0	VF2- 92	CP0847B0
VM1- 95	CP3096A0	VF1- 95	CP0113A0	VM2- 95	CP3096B0	VF2- 95	CP0112B0
VM1-100	CP3008A0	VF1-100	CP0114A0	VM2-100	CP3008B0	VF2-100	CP0010B1
VM1-105	CP3097A0	VF1-105	CP0116A0	VM2-105	CP3097B0	VF2-105	CP0115B0
VM1-106	CP3098A0	VF1-106	CP0117A0	VM2-106	CP3098B0	VF2-106	CP0795B0
VM1-112	CP3099A0	VF1-112	CP0118A0	VM2-112	CP3099B0	VF2-112	CP0796B0

E DIMENSION V99F

V99F TYPE PACKINGS FOR BOTH PISTON AND ROD SEALS (EQUIVALENT TO JIS B 2403)

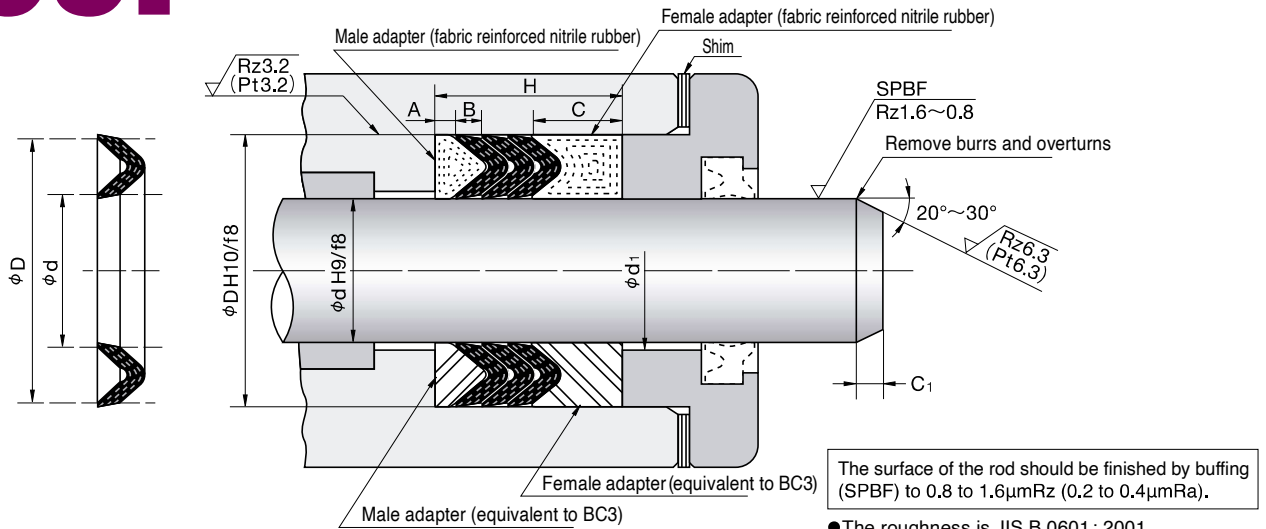

Nominal Number	Nominal Size of Packing			NOK Part Number	Adapter size		Installation length H			C ₁	φd ₁	φD ₁
	d	D	B ^{+0.5 -0.2}		A	C	Number of packings					
F 118	118	138	5	CV0990C0	3	10	28	33	38	5	d+2	D-2
F 120	120	140	5	CV0994C0	3	10	28	33	38	5	d+2	D-2
F 125	125	150	6	CV1018C0	3	12.5	33.5	39.5	45.5	6.5	d+2	D-2
F 132	132	157	6	CV1054C0	3	12.5	33.5	39.5	45.5	6.5	d+2	D-2
F 135	135	160	6	CV1063C0	3	12.5	33.5	39.5	45.5	6.5	d+2	D-2
F 140	140	165	6	CV1088C0	3	12.5	33.5	39.5	45.5	6.5	d+2	D-2
F 145	145	170	6	CV1117C0	3	12.5	33.5	39.5	45.5	6.5	d+2	D-2
F 150	150	175	6	CV1144C0	3	12.5	33.5	39.5	45.5	6.5	d+2	D-2
F 155	155	180	6	CV1177C0	3	12.5	33.5	39.5	45.5	6.5	d+2	D-2
F 160	160	185	6	CV1184C0	3	12.5	33.5	39.5	45.5	6.5	d+2	D-2
F 165	165	190	6	CV1204C0	3	12.5	33.5	39.5	45.5	6.5	d+2	D-2
F 170	170	195	6	CV1216C0	3	12.5	33.5	39.5	45.5	6.5	d+2	D-2
F 175	175	200	6	CV1236C0	3	12.5	33.5	39.5	45.5	6.5	d+2	D-2
F 180	180	205	6	CV1261C0	3	12.5	33.5	39.5	45.5	6.5	d+2	D-2
F 190	190	215	6	CV1287C0	3	12.5	33.5	39.5	45.5	6.5	d+2	D-2
F 199	199	224	6	CV1309C0	3	12.5	33.5	39.5	45.5	6.5	d+2	D-2
F 200	200	225	6	CV1316C0	3	12.5	33.5	39.5	45.5	6.5	d+2	D-2
F 212	212	237	6	CV1351C0	3	12.5	33.5	39.5	45.5	6.5	d+2	D-2
F 224	224	249	6	CV1385C0	3	12.5	33.5	39.5	45.5	6.5	d+2	D-2
F 225	225	250	6	CV1393C0	3	12.5	33.5	39.5	45.5	6.5	d+2	D-2
F 236	236	261	6	CV1417C0	3	12.5	33.5	39.5	45.5	6.5	d+2	D-3
F 250	250	275	6	CV1446C0	3	12.5	33.5	39.5	45.5	6.5	d+2	D-3
Nominal Number	Nominal Size of Packing			NOK Part Number	Adapter size		Installation length H			C ₁	φd ₁	φD ₁
	d	D	B ^{+0.8 -0.3}		A	C	Number of packings					
F 265	265	297	7	CV1487C0	3	16	40	47	54	7.5	d+3	D-3
F 280	280	312	7	CV1513C0	3	16	40	47	54	7.5	d+3	D-3
F 300	300	332	7	CV1540C0	3	16	40	47	54	7.5	d+3	D-3
F 315	315	347	7	CV1570C0	3	16	40	47	54	7.5	d+3	D-3
F 335	335	367	7	CV1593C0	3	16	40	47	54	7.5	d+3	D-3
F 355	355	387	7	CV1608C0	3	16	40	47	54	7.5	d+3	D-3
F 375	375	407	7	CV1631A0	3	16	40	47	54	7.5	d+3	D-3
F 400	400	432	7	CV1642C0	3	16	40	47	54	7.5	d+3	D-3
F 425	425	457	7	CV1665C0	3	16	40	47	54	7.5	d+3	D-3
F 450	450	482	7	CV1889C0	3	16	40	47	54	7.5	d+3	D-3
F 475	475	507	7	CV1681C0	3	16	40	47	54	7.5	d+3	D-3
F 500	500	532	7	CV1692C0	3	16	40	47	54	7.5	d+3	D-3
Nominal Number	Nominal Size of Packing			NOK Part Number	Adapter size		Installation length H			C ₁	φd ₁	φD ₁
	d	D	B ^{+1.2 -0.4}		A	C	Number of packings					
F 530	530	570	8	CV1701C0	3	20	47	55	63	10	d+3	D-3
F 560	560	600	8	CV1890C0	3	20	47	55	63	10	d+3	D-3
F 600	600	640	8	CV1827C0	3	20	47	55	63	10	d+3	D-3
F 630	630	670	8	CV1729C0	3	20	47	55	63	10	d+3	D-3

E DIMENSION V99F

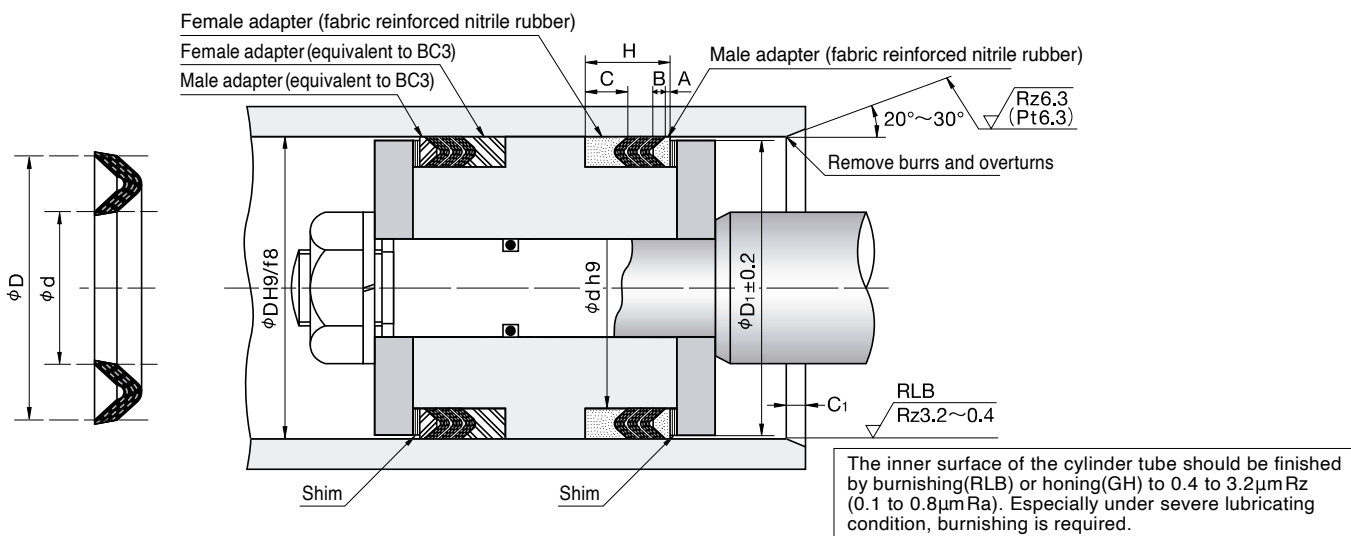

Fabric reinforced nitrile rubber adapter				Metal (equivalent to BC3) adapter			
Male		Female		Male		Female	
Nominal Number	NOK Part Number	Nominal Number	NOK Part Number	Nominal Number	NOK Part Number	Nominal Number	NOK Part Number
VM1-118	CP3655A0	VF1-118	CP0848A0	VM2-118	CP3655B0	VF2-118	CP0797B0
VM1-120	CP3100A0	VF1-120	CP0119A0	VM2-120	CP3100B0	VF2-120	CP0120B0
VM1-125	CP3101A0	VF1-125	CP0121A0	VM2-125	CP3101B0	VF2-125	CP0011B1
VM1-132	CP3656A0	VF1-132	CP0798A0	VM2-132	CP3656B0	VF2-132	CP0799B0
VM1-135	CP3343A0	VF1-135	CP0800A0	VM2-135	CP3343B0	VF2-135	CP0402B0
VM1-140	CP3102A0	VF1-140	CP0211A0	VM2-140	CP3102B0	VF2-140	CP0122B0
VM1-145	CP3103A0	VF1-145	CP0123A0	VM2-145	CP3010B0	VF2-145	CP0012B1
VM1-150	CP3104A0	VF1-150	CP0124A0	VM2-150	CP3104B0	VF2-150	CP0438B0
VM1-155	CP3105A0	VF1-155	CP0125A0	VM2-155	CP3105B0	VF2-155	CP0801B0
VM1-160	CP3039A0	VF1-160	CP0071A0	VM2-160	CP3039B0	VF2-160	CP0126B0
VM1-165	CP3025A0	VF1-165	CP0802A0	VM2-165	CP3025B0	VF2-165	CP0463B0
VM1-170	CP3657A0	VF1-170	CP0803A0	VM2-170	CP3657B0	VF2-170	CP0013B1
VM1-175	CP3061A0	VF1-175	CP0068A0	VM2-175	CP3061B0	VF2-175	CP0638B0
VM1-180	CP3013A0	VF1-180	CP0804A0	VM2-180	CP3013B0	VF2-180	CP0015B1
VM1-190	CP3413A0	VF1-190	CP0805A0	VM2-190	CP3413B0	VF2-190	CP0806B0
VM1-199	CP3069A0	VF1-199	CP0807A0	VM2-199	CP3069B0	VF2-199	CP0078B0
VM1-200	CP3106A0	VF1-200	CP0127A0	VM2-200	CP3106B0	VF2-200	CP0128B0
VM1-212	CP3676A0	VF1-212	CP0062A0	VM2-212	CP3676B0	VF2-212	CP0524B0
VM1-224	CP3658A0	VF1-224	CP0808A0	VM2-224	CP3658B0	VF2-224	CP0809B0
VM1-225	CP3677A0	VF1-225	CP0070A0	VM2-225	CP3677B0	VF2-225	CP0539B1
VM1-236	CP3107A0	VF1-236	CP0810A0	VM2-236	CP3107B0	VF2-236	CP0129B0
VM1-250	CP3062A0	VF1-250	CP0069A0	VM2-250	CP3062B0	VF2-250	CP0563B1
Fabric reinforced nitrile rubber adapter				Metal (equivalent to BC3) adapter			
Male		Female		Male		Female	
Nominal Number	NOK Part Number	Nominal Number	NOK Part Number	Nominal Number	NOK Part Number	Nominal Number	NOK Part Number
VM1-265	CP3108A0	VF1-265	CP0130A0	VM2-265	CP3108B0	VF2-265	CP0583B1
VM1-280	CP3057A0	VF1-280	CP0065A0	VM2-280	CP3057B0	VF2-280	CP0595B1
VM1-300	CP3048A0	VF1-300	CP0056A0	VM2-300	CP3048B0	VF2-300	CP0612B1
VM1-315	CP3015A0	VF1-315	CP0811A0	VM2-315	CP3015B0	VF2-315	CP0017B1
VM1-335	CP3109A0	VF1-335	CP0131A0	VM2-335	CP3109B0	VF2-335	CP0812B0
VM1-355	CP3524A0	VF1-355	CP0813A0	VM2-355	CP3524B0	VF2-355	CP0636B1
VM1-375	CP3016A0	VF1-375	CP0814A0	VM2-375	CP3016B0	VF2-375	CP0018B1
VM1-400	CP3045A0	VF1-400	CP0815A0	VM2-400	CP3045B0	VF2-400	CP0052B0
VM1-425	CP3659A0	VF1-425	CP0849A0	VM2-425	CP3659B0	VF2-425	CP0820B0
VM1-450	CP3660A0	VF1-450	CP0850A0	VM2-450	CP3660B0	VF2-450	CP0816B0
VM1-475	CP3556A0	VF1-475	CP0671A0	VM2-475	CP3556B0	VF2-475	CP0851B0
VM1-500	CP3661A0	VF1-500	CP0817A0	VM2-500	CP3661B0	VF2-500	CP0818B0
Fabric reinforced nitrile rubber adapter				Metal (equivalent to BC3) adapter			
Male		Female		Male		Female	
Nominal Number	NOK Part Number	Nominal Number	NOK Part Number	Nominal Number	NOK Part Number	Nominal Number	NOK Part Number
VM1-530	CP3662A0	VF1-530	CP0819A0	VM2-530	CP3662B0	VF2-530	CP0852B0
VM1-560	CP3110A0	VF1-560	CP0132A0	VM2-560	CP3110B0	VF2-560	CP0133B0
VM1-600	CP3040A0	VF1-600	CP0853A0	VM2-600	CP3040B0	VF2-600	CP0046B0
VM1-630	CP3678A0	VF1-630	CP0854A0	VM2-630	CP3678B0	VF2-630	CP0855B0

E DIMENSION V99F

V96H TYPE

PACKINGS FOR BOTH PISTON AND ROD SEALS NITRILE RUBBER (NBR)



E
DIMENSION
V96H

● Please designate NOK Part number and type & size on your order.

(1) In case of V packing only

VP H 6.3 CV0001F0
 └─ V packing └─ Nominal number └─ Part Number

(2) In case of adapter

VM1- 6.3 CP3673A0
 └─ Nominal Number └─ Part Number

(3) In case of the combination of
V packing and adapter
(In this case, the part number does
not need to be designated.)

VPH 6.3 - 3 1 1
 └─ V packing └─ Nominal number └─ Number of V packings in use └─ Type of male adapter └─ Type of female adapter
 1...fabric reinforced nitrile rubber 2...equivalent to BC3

● Please check the application range on pages 18 and 19 before selecting the type.

Material	V packing only	NOK A505
	Adapter	Type 1 : NOK 21AG (fabric reinforced nitrile rubber) Type 2 : equivalent to BC3 (bronze)
Special order	If you require packings having dimensions not listed in this dimension table or made of materials (rubber) other than the standard, new mold might be necessary. In this case, we will submit to you our quotation for such packings.	
Caution for application	<ol style="list-style-type: none"> After fitting into the groove, no initial tightening is necessary. About the material of adapter If the operation pressure exceeds 8MPa, use the material of BC equivalent. 	

V96H TYPE PACKINGS FOR BOTH PISTON AND ROD SEALS (EQUIVALENT TO JIS B 2403)

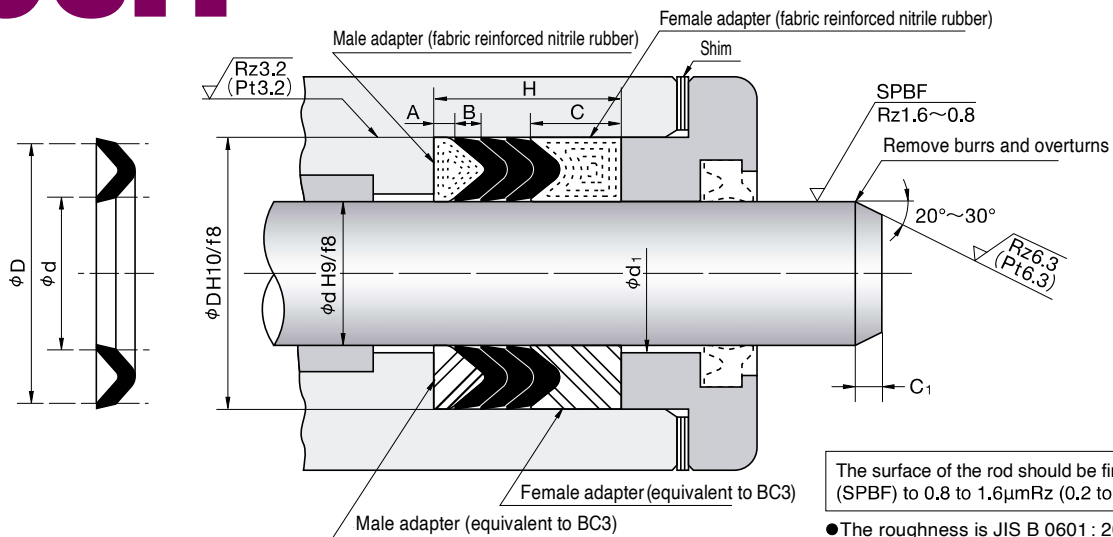

Nominal Number	Nominal Size of Packing			NOK Part Number	Adapter size		Installation length H			C1	φd1	φD1
	d	D	B±0.3		A	C	Number of packings					
H 6.3	6.3	16.3	2.5	CV0001F0	3	5	15.5	18	20.5	2	d+1	D-1
H 7.1	7.1	17.1	2.5	CV0005F0	3	5	15.5	18	20.5	2.5	d+1	D-1
H 8	8	18	2.5	CV0010F0	3	5	15.5	18	20.5	2.5	d+1	D-1
H 9	9	19	2.5	CV0018F0	3	5	15.5	18	20.5	2.5	d+1	D-1
H 10	10	20	2.5	CV0027F0	3	5	15.5	18	20.5	2.5	d+1	D-1
H 11.2	11.2	21.2	2.5	CV0037F0	3	5	15.5	18	20.5	2.5	d+1	D-1
H 12.5	12.5	22.5	2.5	CV0046F0	3	5	15.5	18	20.5	2.5	d+1	D-1
H 14	14	24	2.5	CV0056F0	3	5	15.5	18	20.5	2.5	d+1	D-1
H 16	16	26	2.5	CV0084F0	3	5	15.5	18	20.5	2.5	d+1	D-1
H 15	15	28	3.0	CV0071F0	3	6.5	18.5	21.5	24.5	3.5	d+1	D-1
H 18	18	31	3.0	CV0109F0	3	6.5	18.5	21.5	24.5	3.5	d+1	D-1
H 18.5	18.5	31.5	3.0	CV0114F0	3	6.5	18.5	21.5	24.5	3.5	d+1	D-1
H 20	20	33	3.0	CV0132F0	3	6.5	18.5	21.5	24.5	3.5	d+1	D-1
H 22.4	22.4	35.4	3.0	CV0163F0	3	6.5	18.5	21.5	24.5	3.5	d+1	D-1
H 25	25	38	3.0	CV0176F0	3	6.5	18.5	21.5	24.5	3.5	d+1	D-1
H 27	27	40	3.0	CV0220F0	3	6.5	18.5	21.5	24.5	3.5	d+1	D-1
H 28	28	41	3.0	CV0231F0	3	6.5	18.5	21.5	24.5	3.5	d+1	D-1
H 31.5	31.5	44.5	3.0	CV0280F0	3	6.5	18.5	21.5	24.5	3.5	d+1	D-1
H 32	32	45	3.0	CV0293F0	3	6.5	18.5	21.5	24.5	3.5	d+1	D-1
H 34	34	50	3.5	CV1893F0	3	8	21.5	25	28.5	4	d+1	D-1
H 35.5	35.5	51.5	3.5	CV0338F0	3	8	21.5	25	28.5	4	d+1	D-1
H 40	40	56	3.5	CV0369F0	3	8	21.5	25	28.5	4	d+1	D-1
H 45	45	61	3.5	CV0417F0	3	8	21.5	25	28.5	4	d+1	D-1
H 47	47	63	3.5	CV0440F0	3	8	21.5	25	28.5	4	d+1	D-1
H 50	50	66	3.5	CV0456F0	3	8	21.5	25	28.5	4	d+1	D-1
H 53	53	69	3.5	CV0502F0	3	8	21.5	25	28.5	4	d+1	D-1
H 55	55	71	3.5	CV0517F0	3	8	21.5	25	28.5	4	d+1	D-1
H 56	56	72	3.5	CV0538F0	3	8	21.5	25	28.5	4	d+1	D-1
H 60	60	76	3.5	CV0561F0	3	8	21.5	25	28.5	4	d+1	D-1
H 63	63	79	3.5	CV0598F0	3	8	21.5	25	28.5	4	d+1	D-1
H 64	64	80	3.5	CV0619F0	3	8	21.5	25	28.5	4	d+1	D-1
H 67	67	87	4.0	CV0650F0	3	10	25	29	33	5	d+1	D-2
H 70	70	90	4.0	CV0673F0	3	10	25	29	33	5	d+1	D-2
H 71	71	91	4.0	CV0700F1	3	10	25	29	33	5	d+1	D-2
H 75	75	95	4.0	CV0710F0	3	10	25	29	33	5	d+1	D-2
H 80	80	100	4.0	CV0754F0	3	10	25	29	33	5	d+1	D-2
H 85	85	105	4.0	CV0792F0	3	10	25	29	33	5	d+2	D-2
H 90	90	110	4.0	CV0826F0	3	10	25	29	33	5	d+2	D-2
H 92	92	112	4.0	CV0849F0	3	10	25	29	33	5	d+2	D-2
H 95	95	115	4.0	CV0854F0	3	10	25	29	33	5	d+2	D-2

E DIMENSION V96H

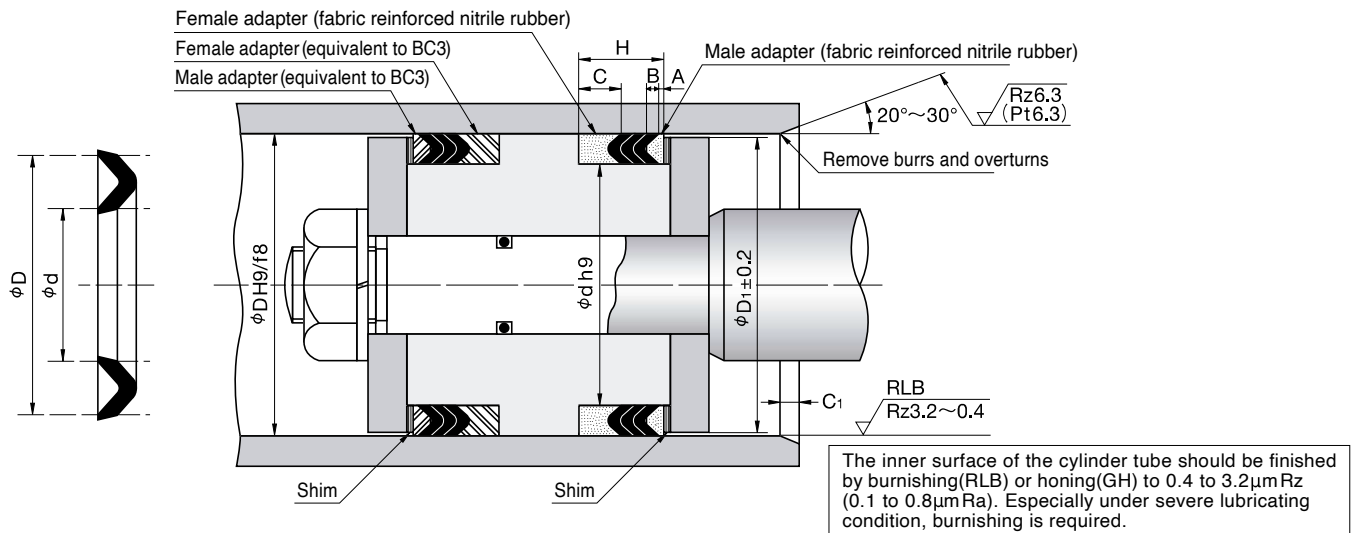

●The roughness is JIS B 0601 : 2001.
When regulation length cannot be kept, apply Pt.

Fabric reinforced nitrile rubber adapter				Metal (equivalent to BC3) adapter			
Male		Female		Male		Female	
Nominal Number	NOK Part Number	Nominal Number	NOK Part Number	Nominal Number	NOK Part Number	Nominal Number	NOK Part Number
VM1- 6.3	CP3673A0	VF1- 6.3	CP0839A0	VM2- 6.3	CP3673B0	VF2- 6.3	CP0840B0
VM1- 7.1	CP3044A0	VF1- 7.1	CP0051A0	VM2- 7.1	CP3044B0	VF2- 7.1	CP0841B0
VM1- 8	CP3081A0	VF1- 8	CP0775A0	VM2- 8	CP3081B0	VF2- 8	CP0091B0
VM1- 9	CP3646A0	VF1- 9	CP0842A0	VM2- 9	CP3646B0	VF2- 9	CP0776B0
VM1- 10	CP3080A0	VF1- 10	CP0777A0	VM2- 10	CP3080B0	VF2- 10	CP0778B0
VM1- 11.2	CP3674A0	VF1- 11.2	CP0843A0	VM2- 11.2	CP3674B0	VF2- 11.2	CP0844B0
VM1- 12.5	CP3077A0	VF1- 12.5	CP0821A0	VM2- 12.5	CP3077B0	VF2- 12.5	CP0086B0
VM1- 14	CP3055A0	VF1- 14	CP0063A0	VM2- 14	CP3055B0	VF2- 14	CP0779B0
VM1- 16	CP3247A0	VF1- 16	CP0780A0	VM2- 16	CP3247B1	VF2- 16	CP0781B0
VM1- 15	CP3082A0	VF1- 15	CP0092A0	VM2- 15	CP3082B0	VF2- 15	CP0093B0
VM1- 18	CP3115A0	VF1- 18	CP0782A0	VM2- 18	CP3115B0	VF2- 18	CP0137B0
VM1- 18.5	CP3647A0	VF1- 18.5	CP0845A0	VM2- 18.5	CP3647B0	VF2- 18.5	CP0783B0
VM1- 20	CP3056A0	VF1- 20	CP0064A0	VM2- 20	CP3056B0	VF2- 20	CP0094B0
VM1- 22.4	CP3083A0	VF1- 22.4	CP0095A0	VM2- 22.4	CP3083B0	VF2- 22.4	CP0784B0
VM1- 25	CP3084A0	VF1- 25	CP0097A0	VM2- 25	CP3084B0	VF2- 25	CP0096B0
VM1- 27	CP3648A0	VF1- 27	CP0785A0	VM2- 27	CP3648B0	VF2- 27	CP0786B0
VM1- 28	CP3070A0	VF1- 28	CP0098A0	VM2- 28	CP3070B0	VF2- 28	CP0079B0
VM1- 31.5	CP3053A0	VF1- 31.5	CP0787A0	VM2- 31.5	CP3053B0	VF2- 31.5	CP0061B0
VM1- 32	CP3078A0	VF1- 32	CP0099A0	VM2- 32	CP3078B0	VF2- 32	CP0087B0
VM1- 34	CP3085A0	VF1- 34	CP0100A0	VM2- 34	CP3085B0	VF2- 34	CP0100B0
VM1- 35.5	CP3649A0	VF1- 35.5	CP0788A0	VM2- 35.5	CP3649B0	VF2- 35.5	CP0788B0
VM1- 40	CP3060A0	VF1- 40	CP0101A0	VM2- 40	CP3060B0	VF2- 40	CP0101B0
VM1- 45	CP3086A0	VF1- 45	CP0102A0	VM2- 45	CP3086B0	VF2- 45	CP0102B0
VM1- 47	CP3650A0	VF1- 47	CP0199A0	VM2- 47	CP3650B0	VF2- 47	CP0199B0
VM1- 50	CP3064A0	VF1- 50	CP0072A0	VM2- 50	CP3064B0	VF2- 50	CP0072B0
VM1- 53	CP3087A0	VF1- 53	CP0103A0	VM2- 53	CP3087B0	VF2- 53	CP0103B0
VM1- 55	CP3651A0	VF1- 55	CP0789A0	VM2- 55	CP3651B0	VF2- 55	CP0789B0
VM1- 56	CP3652A0	VF1- 56	CP0790A0	VM2- 56	CP3652B0	VF2- 56	CP0790B0
VM1- 60	CP3088A0	VF1- 60	CP0104A0	VM2- 60	CP3088B0	VF2- 60	CP0104B0
VM1- 63	CP3089A0	VF1- 63	CP0105A0	VM2- 63	CP3089B0	VF2- 63	CP0105B0
VM1- 64	CP3059A0	VF1- 64	CP0067A0	VM2- 64	CP3090B0	VF2- 64	CP0106B0
VM1- 67	CP3091A0	VF1- 67	CP0107A0	VM2- 67	CP3091B0	VF2- 67	CP0791B0
VM1- 70	CP3051A0	VF1- 70	CP0029A1	VM2- 70	CP3051B0	VF2- 70	CP0059B0
VM1- 71	CP3653A0	VF1- 71	CP0792A0	VM2- 71	CP3653B0	VF2- 71	CP0793B0
VM1- 75	CP3092A0	VF1- 75	CP0109A0	VM2- 75	CP3092B0	VF2- 75	CP0108B0
VM1- 80	CP3007A0	VF1- 80	CP0055A0	VM2- 80	CP3093B0	VF2- 80	CP0009B1
VM1- 85	CP3094A0	VF1- 85	CP0110A0	VM2- 85	CP3094B0	VF2- 85	CP0794B0
VM1- 90	CP3095A0	VF1- 90	CP0111A0	VM2- 90	CP3095B0	VF2- 90	CP0313B0
VM1- 92	CP3675A0	VF1- 92	CP0846A0	VM2- 92	CP3675B0	VF2- 92	CP0847B0
VM1- 95	CP3096A0	VF1- 95	CP0113A0	VM2- 95	CP3096B0	VF2- 95	CP0112B0

V96H TYPE PACKINGS FOR BOTH PISTON AND ROD SEALS (EQUIVALENT TO JIS B 2403)

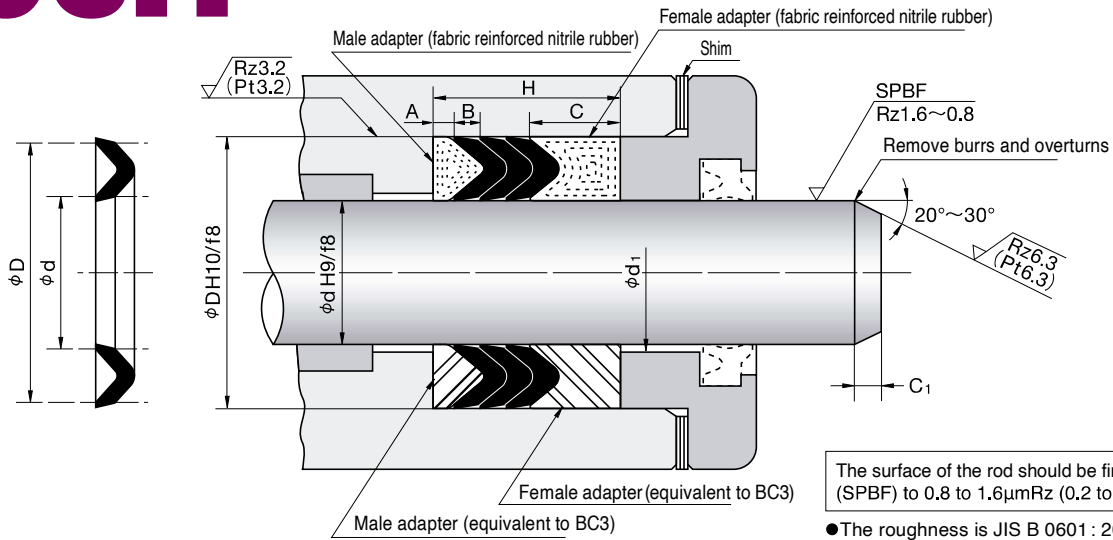

Nominal Number	Nominal Size of Packing			NOK Part Number	Adapter size		Installation length H			C ₁	φd ₁	φD ₁
	d	D	B ± 0.3		A	C	Number of packings					
H 100	100	120	4.0	CV0872F0	3	10	25	29	33	5	d+2	D-2
H 105	105	125	4.0	CV0927F0	3	10	25	29	33	5	d+2	D-2
H 106	106	126	4.0	CV0939F0	3	10	25	29	33	5	d+2	D-2
H 112	112	132	4.0	CV0966F0	3	10	25	29	33	5	d+2	D-2
H 118	118	138	4.0	CV1896F0	3	10	25	29	33	5	d+2	D-2
H 120	120	140	4.0	CV0993F0	3	10	25	29	33	5	d+2	D-2
H 125	125	150	5.0	CV1017F0	3	12.5	30.5	35.5	40.5	6.5	d+2	D-2
H 132	132	157	5.0	CV1053F0	3	12.5	30.5	35.5	40.5	6.5	d+2	D-2
H 135	135	160	5.0	CV1062F0	3	12.5	30.5	35.5	40.5	6.5	d+2	D-2
H 140	140	165	5.0	CV1087F0	3	12.5	30.5	35.5	40.5	6.5	d+2	D-2
H 145	145	170	5.0	CV1116F0	3	12.5	30.5	35.5	40.5	6.5	d+2	D-2
H 150	150	175	5.0	CV1143F0	3	12.5	30.5	35.5	40.5	6.5	d+2	D-2
H 155	155	180	5.0	CV1176F0	3	12.5	30.5	35.5	40.5	6.5	d+2	D-2
H 160	160	185	5.0	CV1183C0	3	12.5	30.5	35.5	40.5	6.5	d+2	D-2
H 165	165	190	5.0	CV1203F0	3	12.5	30.5	35.5	40.5	6.5	d+2	D-2
H 170	170	195	5.0	CV1215F0	3	12.5	30.5	35.5	40.5	6.5	d+2	D-2
H 175	175	200	5.0	CV1235F0	3	12.5	30.5	35.5	40.5	6.5	d+2	D-2
H 180	180	205	5.0	CV1260F0	3	12.5	30.5	35.5	40.5	6.5	d+2	D-2
H 190	190	215	5.0	CV1286F0	3	12.5	30.5	35.5	40.5	6.5	d+2	D-2
H 199	199	224	5.0	CV1308F0	3	12.5	30.5	35.5	40.5	6.5	d+2	D-2
H 200	200	225	5.0	CV1315F0	3	12.5	30.5	35.5	40.5	6.5	d+2	D-2
H 212	212	237	5.0	CV1350F0	3	12.5	30.5	35.5	40.5	6.5	d+2	D-2
H 224	224	249	5.0	CV1384F0	3	12.5	30.5	35.5	40.5	6.5	d+2	D-2
H 225	225	250	5.0	CV1392F0	3	12.5	30.5	35.5	40.5	6.5	d+2	D-2
H 236	236	261	5.0	CV1416F0	3	12.5	30.5	35.5	40.5	6.5	d+2	D-3
H 250	250	275	5.0	CV1445F0	3	12.5	30.5	35.5	40.5	6.5	d+2	D-3
Nominal Number	Nominal Size of Packing			NOK Part Number	Adapter size		Installation length H			C ₁	φd ₁	φD ₁
	d	D	B ± 0.4		A	C	Number of packings					
H 265	265	297	6.0	CV1486F0	3	16	37	43	49	7.5	d+3	D-3
H 280	280	312	6.0	CV1512F0	3	16	37	43	49	7.5	d+3	D-3
H 300	300	332	6.0	CV1539F0	3	16	37	43	49	7.5	d+3	D-3

E DIMENSION V96H

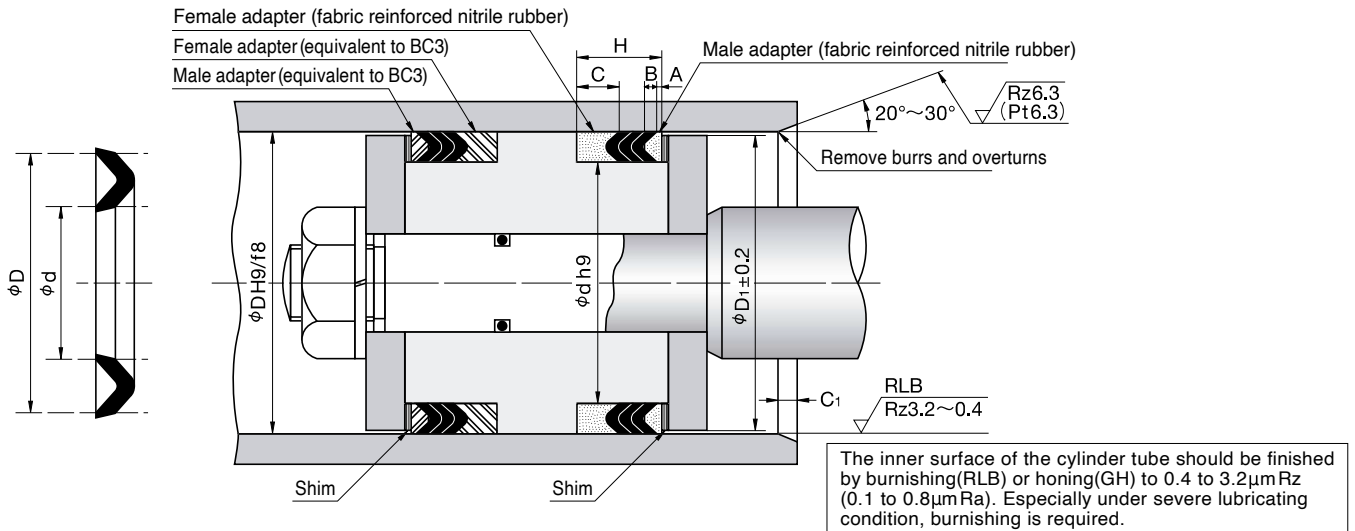

●The roughness is JIS B 0601 : 2001.
When regulation length cannot be kept, apply Pt.

Fabric reinforced nitrile rubber adapter				Metal (equivalent to BC3) adapter			
Male		Female		Male		Female	
Nominal Number	NOK Part Number	Nominal Number	NOK Part Number	Nominal Number	NOK Part Number	Nominal Number	NOK Part Number
VM1-100	CP3008A0	VF1-100	CP0114A0	VM2-100	CP3008B0	VF2-100	CP0010B1
VM1-105	CP3097A0	VF1-105	CP0116A0	VM2-105	CP3097B0	VF2-105	CP0115B0
VM1-106	CP3098A0	VF1-106	CP0117A0	VM2-106	CP3098B0	VF2-106	CP0795B0
VM1-112	CP3099A0	VF1-112	CP0118A0	VM2-112	CP3099B0	VF2-112	CP0796B0
VM1-118	CP3655A0	VF1-118	CP0848A0	VM2-118	CP3655B0	VF2-118	CP0797B0
VM1-120	CP3100A0	VF1-120	CP0119A0	VM2-120	CP3100B0	VF2-120	CP0120B0
VM1-125	CP3101A0	VF1-125	CP0121A0	VM2-125	CP3101B0	VF2-125	CP0011B1
VM1-132	CP3656A0	VF1-132	CP0798A0	VM2-132	CP3656B0	VF2-132	CP0799B0
VM1-135	CP3343A0	VF1-135	CP0800A0	VM2-135	CP3343B0	VF2-135	CP0402B0
VM1-140	CP3102A0	VF1-140	CP0211A0	VM2-140	CP3102B0	VF2-140	CP0122B0
VM1-145	CP3103A0	VF1-145	CP0123A0	VM2-145	CP3010B0	VF2-145	CP0012B1
VM1-150	CP3104A0	VF1-150	CP0124A0	VM2-150	CP3104B0	VF2-150	CP0438B0
VM1-155	CP3105A0	VF1-155	CP0125A0	VM2-155	CP3105B0	VF2-155	CP0801B0
VM1-160	CP3039A0	VF1-160	CP0071A0	VM2-160	CP3039B0	VF2-160	CP0126B0
VM1-165	CP3025A0	VF1-165	CP0802A0	VM2-165	CP3025B0	VF2-165	CP0463B0
VM1-170	CP3657A0	VF1-170	CP0803A0	VM2-170	CP3657B0	VF2-170	CP0013B1
VM1-175	CP3061A0	VF1-175	CP0068A0	VM2-175	CP3061B0	VF2-175	CP0638B0
VM1-180	CP3013A0	VF1-180	CP0804A0	VM2-180	CP3013B0	VF2-180	CP0015B1
VM1-190	CP3413A0	VF1-190	CP0805A0	VM2-190	CP3413B0	VF2-190	CP0806B0
VM1-199	CP3069A0	VF1-199	CP0807A0	VM2-199	CP3069B0	VF2-199	CP0078B0
VM1-200	CP3106A0	VF1-200	CP0127A0	VM2-200	CP3106B0	VF2-200	CP0128B0
VM1-212	CP3676A0	VF1-212	CP0062A0	VM2-212	CP3676B0	VF2-212	CP0524B0
VM1-224	CP3658A0	VF1-224	CP0808A0	VM2-224	CP3658B0	VF2-224	CP0809B0
VM1-225	CP3677A0	VF1-225	CP0070A0	VM2-225	CP3677B0	VF2-225	CP0539B1
VM1-236	CP3107A0	VF1-236	CP0810A0	VM2-236	CP3107B0	VF2-236	CP0129B0
VM1-250	CP3062A0	VF1-250	CP0069A0	VM2-250	CP3062B0	VF2-250	CP0563B1
Fabric reinforced nitrile rubber adapter				Metal (equivalent to BC3) adapter			
Male		Female		Male		Female	
Nominal Number	NOK Part Number	Nominal Number	NOK Part Number	Nominal Number	NOK Part Number	Nominal Number	NOK Part Number
VM1-265	CP3108A0	VF1-265	CP0130A0	VM2-265	CP3108B0	VF2-265	CP0583B1
VM1-280	CP3057A0	VF1-280	CP0065A0	VM2-280	CP3057B0	VF2-280	CP0595B1
VM1-300	CP3048A0	VF1-300	CP0056A0	VM2-300	CP3048B0	VF2-300	CP0612B1

E
DIMENSION
V96H

DKI TYPE DUST SEALS FOR RECIPROCAL MOVEMENT

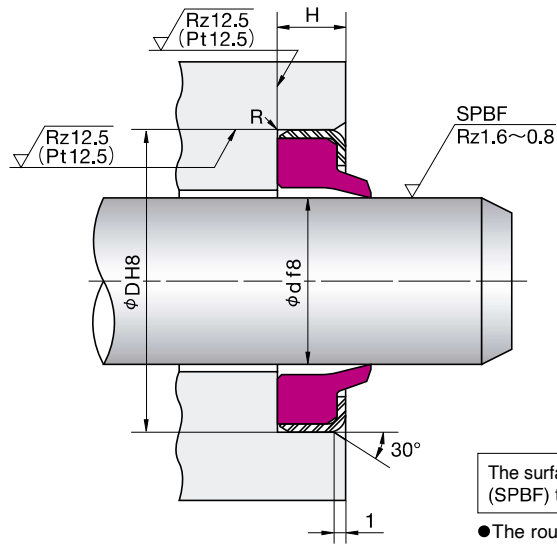
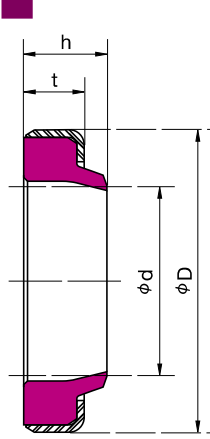

R = 0.3 or below

The surface of the rod should be finished by buffing (SPBF) to 0.8 to 1.6μmRz (0.2 to 0.4μmRa).

● The roughness is JIS B 0601 : 2001.
When regulation length cannot be kept, apply Pt.

E DIMENSION
DKI

Nominal Size of Dust Seal, and Housing dimensions					NOK Part Number
d	D	t	h	H ^{+0.5} / _{+0.3}	
6.3	16	5	7	5	FD0064A0
7.1	17	5	7	5	FD0095A0
8	18	5	7	5	FD0142A0
9	19	5	7	5	FD0199A0
10	20	5	7	5	FD0258A0
11.2	21	5	7	5	FD0332A0
12.5	23	5	7	5	FD0412A0
14	24	5	7	5	FD0513A0
15	25	5	7	5	FD0586A0
16	26	5	7	5	FD0677A0
18	30	6	9	6	FD0815A0
20	32	6	9	6	FD0995A0
22.4	34.4	6	9	6	FD1203A0
25	37	6	9	6	FD1301A0
27	39	6	9	6	FD1503A0
28	40	6	9	6	FD1536A0
30	42	6	9	6	FD1664A0
31.5	44	7	10	7	FD1803A0
32	44	7	10	7	FD1870A0
35	47	7	10	7	FD2041A0
35.5	47.5	7	10	7	FD2149A0
38	50	7	10	7	FD2217A0
40	52	7	10	7	FD2342A0
45	57	7	10	7	FD2633A0
47	59	7	10	7	FD2729A0
50	62	7	10	7	FD2831A0
Nominal Size of Dust Seal, and Housing dimensions					NOK Part Number
d	D	t	h	H ^{+0.6} / _{+0.4}	
53	67	8	11	8	FD2985A0
55	69	8	11	8	FD3033A0
56	70	8	11	8	FD3089A0
60	74	8	11	8	FD3187A0
63	77	8	11	8	FD3313A0
64	78	8	11	8	FD3366A0
65	79	8	11	8	FD3381A0
67	81	8	11	8	FD3447A0
70	84	8	11	8	FD3493A0
71	85	8	11	8	FD3546A0
75	89	8	11	8	FD3596A0
80	94	8	11	8	FD3720A0
85	99	8	11	8	FD3828A0
90	104	8	11	8	FD3913A0
92	106	8	11	8	FD3957A0
95	109	8	11	8	FD3976A0
100	114	8	11	8	FD4046A0

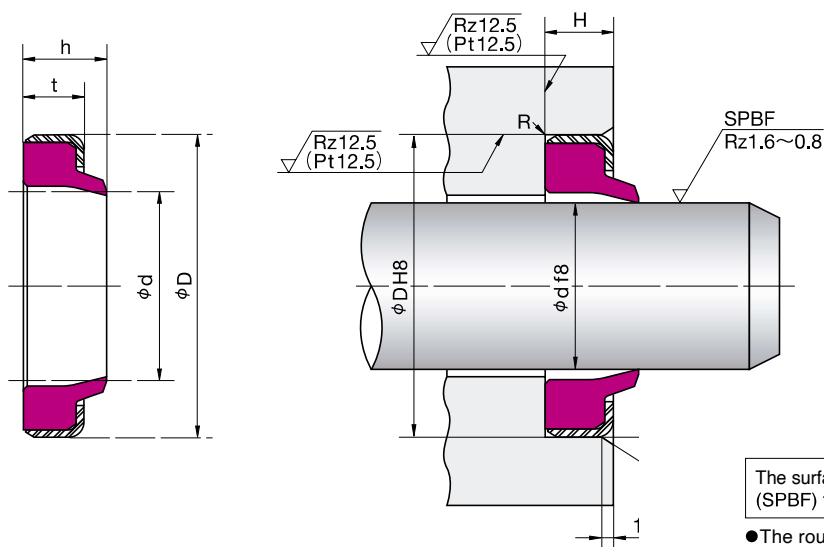

R = 0.3 or below

The surface of the rod should be finished by buffing (SPBF) to 0.8 to 1.6μmRz (0.2 to 0.4μmRa).

● The roughness is JIS B 0601 : 2001.
When regulation length cannot be kept, apply Pt.

Nominal Size of Dust Seal, and Housing dimensions					NOK Part Number
d	D	t	h	H ^{+0.6} / _{+0.4}	
105	121	9	12	9	FD4142A0
106	122	9	12	9	FD4168A0
108	125	9	12	9	FD4187E0
110	126	9	12	9	FD4196A0
112	128	9	12	9	FD4232A0
115	131	9	12	9	FD4272E0
118	134	9	12	9	FD4317A0
120	136	9	12	9	FD4326A0
125	141	9	12	9	FD4393A0
130	146	9	12	9	FD4438A0
132	148	9	12	9	FD4476A0
135	155	10	14	10	FD4492A0
140	160	10	14	10	FD4533A0
145	165	10	14	10	FD4578A0
150	170	10	14	10	FD4615A0
155	175	10	14	10	FD4663E0
160	180	10	14	10	FD4704A0
165	185	10	14	10	FD4733A0
170	190	10	14	10	FD4785A0
175	195	10	14	10	FD4839A0
Nominal Size of Dust Seal, and Housing dimensions					NOK Part Number
d	D	t	h	H ^{+0.7} / _{+0.5}	
180	205	12	17	12	FD4890A0
185	210	12	17	12	FD4941E0
190	215	12	17	12	FD4969A0
200	225	12	17	12	FD5048A0
210	235	12	17	12	FD5129E0
212	237	12	17	12	FD5151A0
220	245	12	17	12	FD5200A0
224	249	12	17	12	FD5237A0
225	250	12	17	12	FD5245F0
230	255	12	17	12	FD5277A0
236	261	12	17	12	FD5326A0
240	265	12	17	12	FD5336A0
245	270	12	17	12	FD5379E0
250	275	12	17	12	FD5396A0
260	285	12	17	12	FD5451E0
265	290	12	17	12	FD5480A0
280	310	16	22	16	FD5556A0
290	320	16	22	16	FD5584E0
300	330	16	22	16	FD5622A0

DWI TYPE DUST SEALS FOR RECIPROCAL MOVEMENT

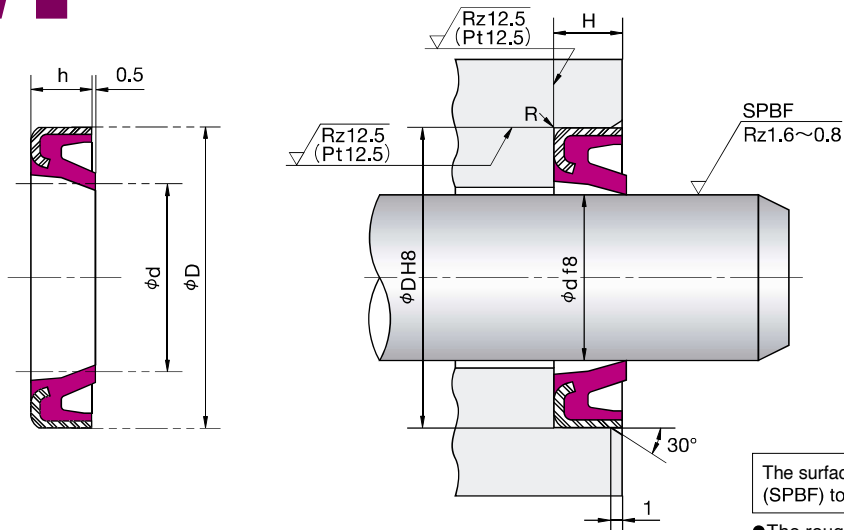

Nominal Size of Dust Seal, and Housing dimensions				NOK Part Number
d	D	h	$H^{+0.5}_{+0.3}$	
40	52	7	7	FD2342G0
45	57	7	7	FD2633H0
50	62	7	7	FD2831F0
Nominal Size of Dust Seal, and Housing dimensions				NOK Part Number
d	D	h	$H^{+0.6}_{+0.4}$	
55	69	8	8	FD3033F0
60	74	8	8	FD3187H0
61	74	8	8	FD6782E0
63	77	8	8	FD3313E0
65	79	8	8	FD3381I0
70	84	8	8	FD3493I0
75	89	8	8	FD3596F0
80	94	8	8	FD3720G0
85	99	8	8	FD3828H0
90	104	8	8	FD3913F0
95	109	8	8	FD3976L0
100	114	8	8	FD4046F0
105	121	9	9	FD4142I0
110	126	9	9	FD4196F0
120	136	9	9	FD4326F0
130	146	9	9	FD4438G0
140	160	10	10	FD4533G0

E
DIMENSION
D
W
I

DWIR_{TYPE}

DUST SEALS FOR
RECIPROCAL MOVEMENT
IRON RUBBER (PUR)



E
DIMENSION
DWIR

- Please designate NOK Part number and type & size on your order.

(Example) • Type Dimensions DWIR 25 37 6 6.9

Type Sign

Nominal Size of Dust Seal
described in order of

inner diameter(d), outer diameter(D), thickness(t), and height(h)

• Part Number FD1301G0

- Please check the application range on pages 20 and 21 before selecting the type.

Material	NOK U801 + Metal case (SPCC)
-----------------	------------------------------

DWIR^{TYPE} DUST SEALS FOR RECIPROCAL MOVEMENT

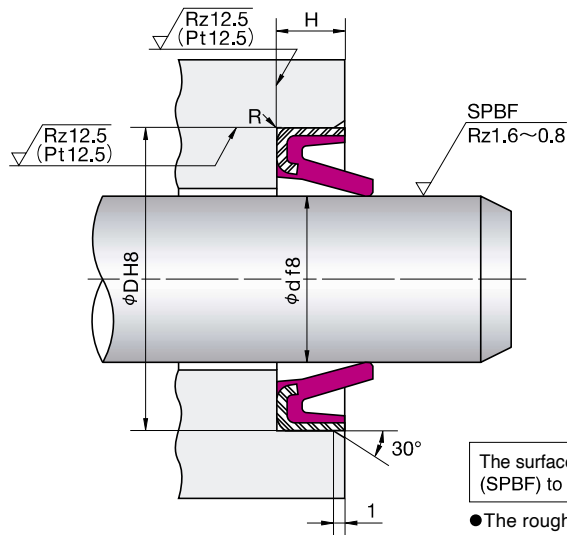
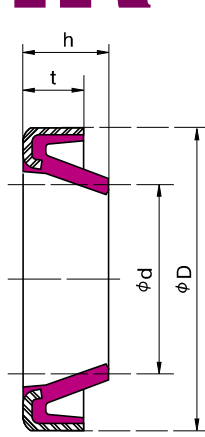

The surface of the rod should be finished by buffing (SPBF) to 0.8 to 1.6μmRz (0.2 to 0.4μmRa).

● The roughness is JIS B 0601 : 2001.
When regulation length cannot be kept, apply Pt.

Nominal Size of Dust Seal, and Housing dimensions					NOK Part Number
d	D	t	h	H ^{+0.5} / _{+0.3}	
25	37	6	6.9	6	FD1301G0
30	42	6	6.9	6	FD1664I0
35	47	7	7.9	7	FD2041J0
40	52	7	10	7	FD2342H0
45	57	7	10	7	FD2633J0
Nominal Size of Dust Seal, and Housing dimensions					NOK Part Number
d	D	t	h	H ^{+0.6} / _{+0.4}	
55	69	8	11.3	8	FD3033I0
60	74	8	11.3	8	FD3187G0
65	79	8	11.3	8	FD3381G0
70	84	8	11.3	8	FD3493K0
75	89	8	11.3	8	FD3596I0
80	94	8	11.3	8	FD3720K0
85	99	8	11.3	8	FD3828M0
90	104	8	11.3	8	FD3913G0
95	109	8	11.3	8	FD3976K0
100	114	8	11.3	8	FD4046G0
105	121	9	12.3	9	FD4142H0
110	126	9	12.3	9	FD4196G0
120	136	9	12.3	9	FD4326G0
130	146	9	12.3	9	FD4438H0
140	160	10	13.3	10	FD4533H0

E DIMENSION DWIR

DKBI TYPE DUST SEALS FOR RECIPROCAL MOVEMENT

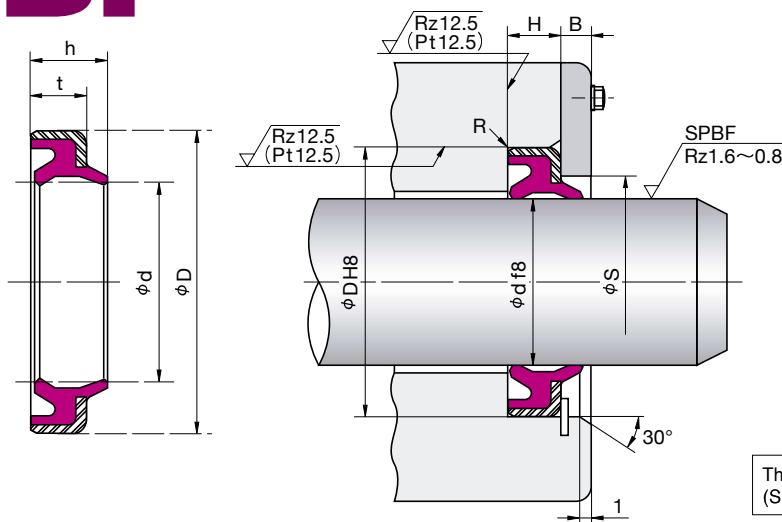

Pressure plate system

Reference

Circlip system

R = 0.3 or below

The surface of the rod should be finished by buffing (SPBF) to 0.8 to 1.6 μ mRz (0.2 to 0.4 μ mRa).

- The roughness is JIS B 0601 : 2001.
When regulation length cannot be kept, apply Pt.

Nominal Size of Dust Seal, and Housing dimensions							NOK Part Number	
d	D	t	h	H ^{+0.5} _{+0.3}	φS	B	Standard (U801)	Heat resistant (U641)
20	32	6	9	6	27	4	FD0995F0	FD0995F4
25	37	6	9	6	32	4	FD1301E0	FD1301E3
30	42	6	9	6	37	4	FD1664E0	FD1664E3
32	44	7	10	7	39	4	FD1870E0	FD1870E3
35	47	7	10	7	42	4	FD2041E1	FD2041E4
40	52	7	10	7	47	4	FD2342F0	FD2342F3
45	57	7	10	7	52	4	FD2633G0	FD2633G3
50	62	7	10	7	57	4	FD2831E0	FD2831E3
Nominal Size of Dust Seal, and Housing dimensions							NOK Part Number	
d	D	t	h	H ^{+0.5} _{+0.4}	φS	B	Standard (U801)	Heat resistant (U641)
55	69	8	11	8	62	4	FD3033E1	FD3033E5
60	74	8	11	8	67	4	FD3187E0	FD3187E3
65	79	8	11	8	72	4	FD3381E0	FD3381E3
70	84	8	11	8	77	4	FD3493E0	FD3493E2
75	89	8	11	8	82	4	FD3596E0	FD3596E1
80	94	8	12	8	87	4	FD3720E0	FD3720N0
85	99	8	11	8	92	4	FD3828G0	FD3828G1
90	104	8	11	8	97	4	FD3913E0	FD3913E1
95	109	8	11	8	102	4	FD3976E0	FD3976E3
100	114	8	11	8	107	4	FD4046E1	FD4046E2
105	121	9	12	9	113	5	FD6722E0	FD6722E1
110	126	9	12	9	118	5	FD4196E0	FD4196E3
115	131	9	12	9	123	5	FD4272I0	FD4272I1
120	136	9	12	9	128	5	FD4326E0	FD4326E1
130	146	9	12	9	138	5	FD4438F0	FD4438F3
140	160	10	14	10	150	5	FD4533E0	FD4533E3

E
DIMENSION
DKBI

DKBI3 TYPE

**DUST SEALS FOR
RECIPROCAL MOVEMENT
IRON RUBBER (PUR)**



E
DIMENSION
DKBI3

- Please designate NOK Part number and type & size on your order.

(Example) • Type Dimensions DKBI3 20 32 6 9

— Type Sign

— Nominal Size of Dust Seal described in order of inner diameter(d), outer diameter(D), thickness(t), and height(h)

• Part Number FD0995F1

- Please check the application range on pages 20 and 21 before selecting the type.

Material	Standard : NOK U801 Heat resistant type : NOK U641 + Metal case (SPCC)
-----------------	---

DKBI3^{TYPE} DUST SEALS FOR RECIPROCAL MOVEMENT

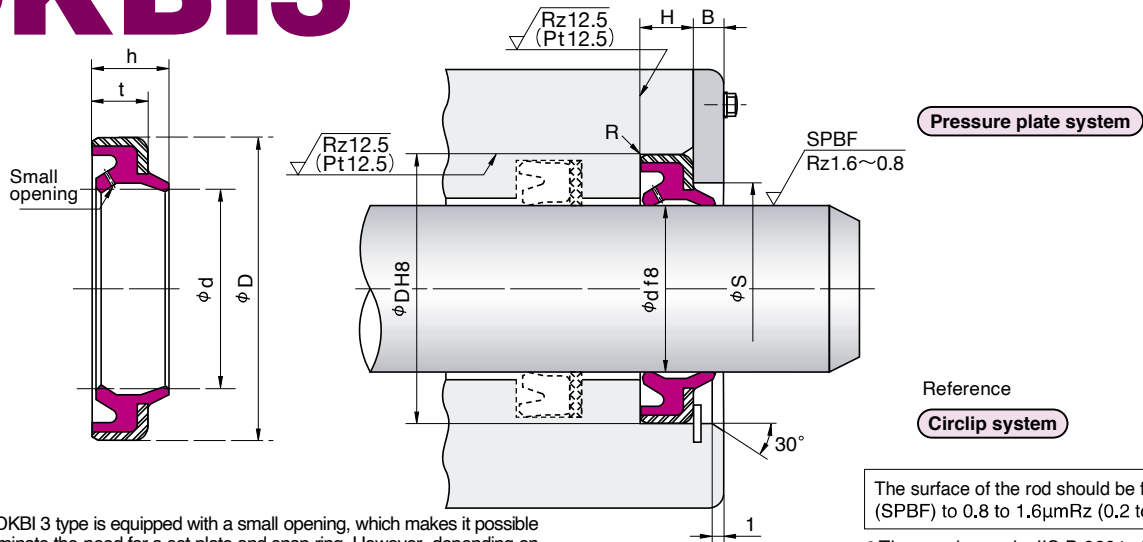

Pressure plate system

Reference

Circlip system

R = 0.3 or below

The surface of the rod should be finished by buffing (SPBF) to 0.8 to 1.6µmRz (0.2 to 0.4µmRa).

Note: The DKBI 3 type is equipped with a small opening, which makes it possible to eliminate the need for a set plate and snap ring. However, depending on the usage environment, external dust and internal contamination may block the small opening, preventing pressure from being released.

- The roughness is JIS B 0601 : 2001. When regulation length cannot be kept, apply Pt.

Nominal Number	Nominal Size of Packing, and Housing dimensions							NOK Part Number	
	d	D	t	h	H ^{+0.5} _{+0.3}	φS	B	Standard (U801)	Heat resistant (U641)
DKBI3 20	20	32	6	9	6	27	4	FD0995F1	FD0995F2
25	25	37	6	9	6	32	4	FD1301E1	FD1301E2
30	30	42	6	9	6	37	4	FD1664E1	FD1664E2
32	32	44	7	10	7	39	4	FD1870E1	FD1870E2
35	35	47	7	10	7	42	4	FD2041E2	FD2041E3
40	40	52	7	10	7	47	4	FD2342F1	FD2342F2
45	45	57	7	10	7	52	4	FD2633G1	FD2633G2
50	50	62	7	10	7	57	4	FD2831E1	FD2831E2
Nominal Number	Nominal Size of Packing, and Housing dimensions							NOK Part Number	
	d	D	t	h	H ^{+0.6} _{+0.4}	φS	B	Standard (U801)	Heat resistant (U641)
DKBI3 55	55	69	8	11	8	62	4	FD3033E4	FD3033E3
60	60	74	8	11	8	67	4	FD3187E1	FD3187E2
65	65	79	8	11	8	72	4	FD3381E2	FD3381E1
70	70	84	8	11	8	77	4	FD3493E5	FD3493E3
75	75	89	8	11	8	82	4	FD3596E3	FD3596E2
80	80	94	8	12	8	87	4	FD3720E2	FD3720E1
85	85	99	8	11	8	92	4	FD3828G2	FD3828G3
90	90	104	8	11	8	97	4	FD3913E2	FD3913E3
95	95	109	8	11	8	102	4	FD3976E1	FD3976E2
100	100	114	8	11	8	107	4	FD4046E4	FD4046E3
105	105	121	9	12	9	113	5	FD6722E2	FD6722E3
110	110	126	9	12	9	118	5	FD4196E1	FD4196E2
115	115	131	9	12	9	123	5	FD4272I3	FD4272I2
120	120	136	9	12	9	128	5	FD4326E2	FD4326E3
130	130	146	9	12	9	138	5	FD4438F1	FD4438F2
140	140	160	10	14	10	150	5	FD4533E1	FD4533E2

E DIMENSION DKBI-3

DKBZ TYPE

DUST SEALS FOR
RECIPROCAL MOVEMENT
IRON RUBBER (PUR)



E
DIMENSION
DKBZ

- Please designate NOK Part number and type & size on your order.

(Example) · Type Dimensions DKBZ 20 32 6 9

Type Sign

Nominal Size of Dust Seal
described in order of
inner diameter(d), outer diameter(D), thickness(t), and height(h)

· Part Number FD0995B0

- Please check the application range on pages 20 and 21 before selecting the type.

Material	NOK U801 + Metal case (SPCC)
-----------------	------------------------------

DKBZ TYPE DUST SEALS FOR RECIPROCAL MOVEMENT

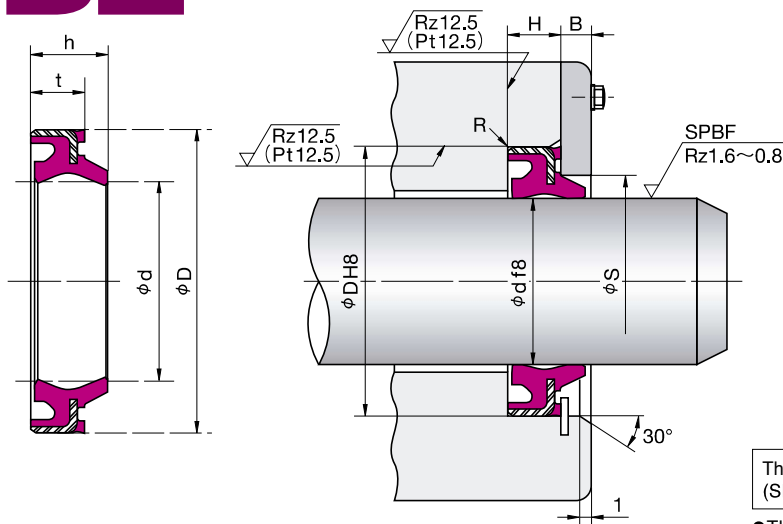

Pressure plate system

Reference

Circlip system

R = 0.3 or below

The surface of the rod should be finished by buffing (SPBF) to 0.8 to 1.6μmRz (0.2 to 0.4μmRa).

● The roughness is JIS B 0601 : 2001.
When regulation length cannot be kept, apply Pt.

Nominal Number	Nominal Size of Packing, and Housing dimensions							NOK Part Number
	d	D	t	h	$H_{+0.5}^{+0.3}$	φS	B	
DKBZ 20	20	32	6	9	6	27	4	FD0995B0
25	25	37	6	9	6	32	4	FD1301B0
30	30	42	6	9	6	37	4	FD1664B0
35	35	47	7	10	7	42	4	FD2041B0
40	40	52	7	10	7	47	4	FD2342B0
45	45	57	7	10	7	52	4	FD2633B0
50	50	62	7	10	7	57	4	FD2831B0
Nominal Number	Nominal Size of Packing, and Housing dimensions							NOK Part Number
	d	D	t	h	$H_{+0.6}^{+0.4}$	φS	B	
DKBZ 55	55	69	8	11.5	8	62	4	FD3033B0
60	60	74	8	11.5	8	67	4	FD3187B0
65	65	79	8	11.5	8	72	4	FD3381B0
70	70	84	8	11.5	8	77	4	FD3493B0
75	75	89	8	11.5	8	82	4	FD3596B0
80	80	94	8	11.5	8	87	4	FD3720B0
85	85	99	8	11.5	8	92	4	FD3828B0
90	90	104	8	11.5	8	97	4	FD3913B0
95	95	109	8	11.5	8	102	4	FD3976B0
100	100	114	8	11.5	8	107	4	FD4046B0
105	105	121	9	13	9	113	5	FD6722B0
110	110	126	9	13	9	118	5	FD4196B0
115	115	131	9	13	9	123	5	FD4272B0
120	120	136	9	13	9	128	5	FD4326B0
130	130	146	9	13	9	138	5	FD4438B0
140	140	160	10	15	10	150	5	FD4533B0
160	160	180	10	15	10	170	5	FD4704B0
170	170	190	10	15	10	180	5	FD4785B0

E DIMENSION
DKBZ

DKB TYPE DUST SEALS FOR RECIPROCAL MOVEMENT

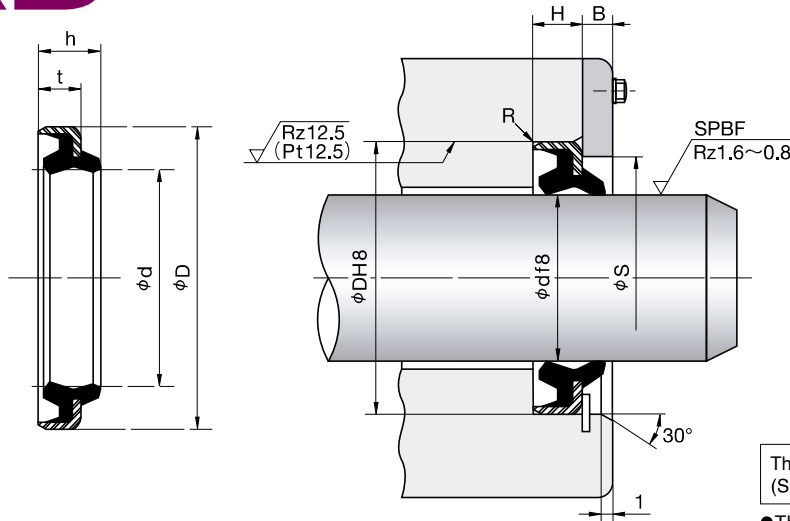

Pressure plate system

Reference

Circlip system

R = 0.3 or below

The surface of the rod should be finished by buffing (SPBF) to 0.8 to 1.6μmRz (0.2 to 0.4μmRa).

● The roughness is JIS B 0601 : 2001.
When regulation length cannot be kept, apply Pt.

Nominal Size of Dust Seal, and Housing dimensions							NOK
d	D	t	h	H _{±0.03} ^{+0.05}	φS	B	Part Number
14	24	5	7	5	19	4	AR0513F5
16	26	5	7	5	21	4	AR0677E5
18	30	6	9	6	25	4	AR0815F5
20	32	6	9	6	27	4	AR0995E1
22	34	6	9	6	29	4	AR1121F5
22.4	34.4	6	9	6	29	4	AR1203F5
25	37	6	9	6	32	4	AR1301H5
28	40	6	9	6	35	4	AR1536F5
30	42	6	9	6	37	4	AR1664F5
31.5	44	7	10	7	38.5	4	AR1803G5
32	44	7	10	7	39	4	AR1870F5
35	47	7	10	7	42	4	AR2041E5
35.5	47.5	7	10	7	42.5	4	AR2149F5
36	48	7	10	7	43	4	BR1418E5
40	52	7	10	7	47	4	AR2342E5
45	57	7	10	7	52	4	AR2633G5
50	62	7	10	7	57	4	AR2831F5
Nominal Size of Dust Seal, and Housing dimensions							NOK
d	D	t	h	H _{±0.04} ^{+0.06}	φS	B	Part Number
55	69	8	11	8	62	4	AR3033F5
56	70	8	11	8	63	4	AR3089G5
60	74	8	11	8	67	4	AR3187G5
63	77	8	11	8	70	4	AR3313F5
65	79	8	11	8	72	4	AR3381F5
70	84	8	11	8	77	4	AR3493F5
75	89	8	11	8	82	4	AR3596G5
80	94	8	11	8	87	4	AR3720I5
85	99	8	11	8	92	4	AR3828F5
90	104	8	11	8	97	4	AR3913E0
95	109	8	11	8	102	4	AR3976G5
100	114	8	11	8	107	4	AR4046G5
105	121	9	12	9	113	5	AR4142F5
110	126	9	12	9	118	5	AR4196F5
112	128	9	12	9	120	5	AR4232F5
120	136	9	12	9	128	5	AR4326E5
125	141	9	12	9	133	5	AR4393F5
140	160	10	14	10	150	5	AR4533G5
145	165	10	14	10	155	5	AR4578E5
150	170	10	14	10	160	5	AR4615E5
155	175	10	14	10	165	5	AR4663E5
160	180	10	14	10	170	5	AR4704G5
170	190	10	14	10	180	5	AR4785E5
175	195	10	14	10	185	5	AR4839F5
Nominal Size of Dust Seal, and Housing dimensions							NOK
d	D	t	h	H _{±0.05} ^{+0.07}	φS	B	Part Number
180	205	12	17	12	191	5	AR4890G5
200	225	12	17	12	212	6	AR5048G5
225	250	12	17	12	237	6	AR5245F5
250	275	12	17	12	262	6	AR5396F5

E DIMENSION DKB

DKH TYPE DUST SEALS FOR RECIPROCAL MOVEMENT

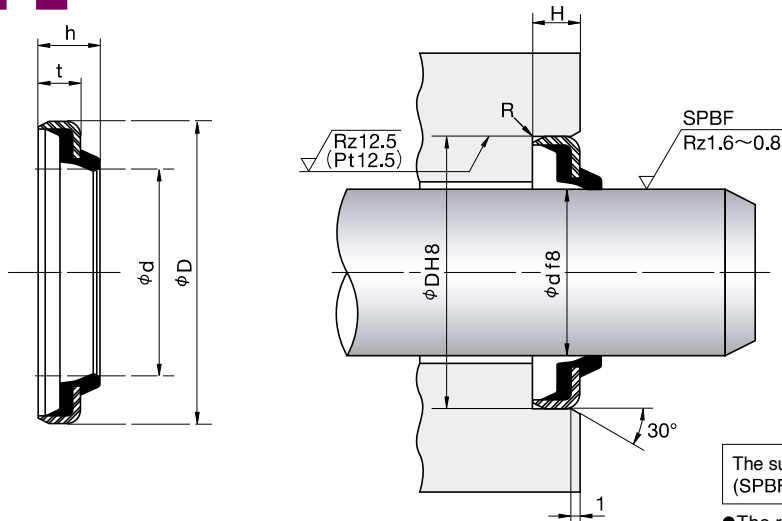

R = 0.3 or below

The surface of the rod should be finished by buffing (SPBF) to 0.8 to 1.6μmRz (0.2 to 0.4μmRa).

● The roughness is JIS B 0601 : 2001.
When regulation length cannot be kept, apply Pt.

Nominal Size of Dust Seal, and Housing dimensions					NOK Part Number
d	D	t	h	H ^{+0.5} / _{+0.3}	
10	20	5	7	5	AR0258E5
15	25	5	7	5	AR0586E5
20	32	6	9	6	AR0995F5
22.4	34.4	6	9	6	AR1203G5
25	37	6	9	6	AR1301F5
28	40	6	9	6	AR1536G5
30	42	6	9	6	AR1664G5
35	47	7	10	7	AR2041F5
35.5	47.5	7	10	7	AR2149J5
40	52	7	10	7	AR2342F5
45	57	7	10	7	AR2633I5
50	62	7	10	7	AR2831H5
Nominal Size of Dust Seal, and Housing dimensions					NOK Part Number
d	D	t	h	H ^{+0.6} / _{+0.4}	
55	69	8	11	8	AR3033G5
60	74	8	11	8	AR3187J5
65	79	8	11	8	AR3381G5
80	94	8	11	8	AR3720H5
85	99	8	11	8	AR3828G5
90	104	8	11	8	AR3913F5
95	109	8	11	8	AR3976H5
100	114	8	11	8	AR4046E5
105	121	9	12	9	AR4142E5
120	136	9	12	9	AR4326H5
130	146	9	12	9	AR4438E5
155	175	10	14	10	AR4663F5
Nominal Size of Dust Seal, and Housing dimensions					NOK Part Number
d	D	t	h	H ^{+0.7} / _{+0.5}	
210	235	12	17	12	AR5129E5
230	255	12	17	12	AR5277E5
240	265	12	17	12	AR5336E5
265	290	12	17	12	AR5480E5
300	330	16	22	16	AR5622B5
310	340	16	22	16	AR5668B5
315	345	16	22	16	AR5685B5
330	360	16	22	16	AR5741B5
335	365	16	22	16	AR5761B5
440	480	18	24	18	AR6021B5
Nominal Size of Dust Seal, and Housing dimensions					NOK Part Number
d	D	t	h	H ^{+0.8} / _{+0.6}	
460	490	20	25	20	AR6073B5
470	510	20	25	20	AR6094B5
Nominal Size of Dust Seal, and Housing dimensions					NOK Part Number
d	D	t	h	H ^{+0.7} / _{+0.5}	
500	530	16	22	16	AR6140B5

E DIMENSION DKH

DSI TYPE

DUST SEALS FOR RECIPROCAL MOVEMENT IRON RUBBER (PUR)



E
DIMENSION
DSI

- Please designate NOK Part number and type & size on your order.

(Example) · Type Dimensions DSI 6.3 14.3 4.5 6

└─ Type Sign

└─ Nominal Size of Dust Seal
described in order of
inner diameter(d), outer diameter(D), thickness(t), and height(h)

· Part Number FQ0000D0

- Please check the application range on pages 20 and 21 before selecting the type.

Material	NOK U801
-----------------	----------

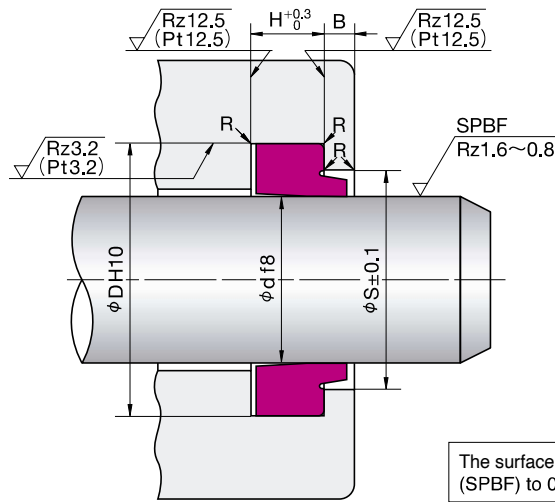
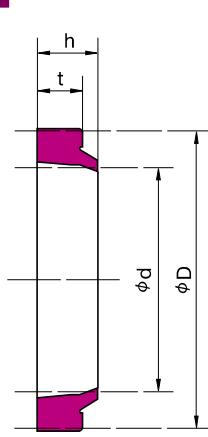

R = 0.3 or below

The surface of the rod should be finished by buffing (SPBF) to 0.8 to 1.6μmRz (0.2 to 0.4μmRa).

● The roughness is JIS B 0601 : 2001.
When regulation length cannot be kept, apply Pt.

Nominal Size of Dust Seal, and Housing dimensions							NOK Part Number
d	D	t	h	H	φS	B	
6.3	14.3	4.5	6	5	10.3	2	FQ0000D0
8	16	4.5	6	5	12	2	FQ0002D0
9	17	4.5	6	5	13	2	FQ0003D0
10	18	4.5	6	5	14	2	FQ0004D0
11.2	19.2	4.5	6	5	15.2	2	FQ0005D0
12.5	20.5	4.5	6	5	16.5	2	FQ0006D0
14	22	4.5	6	5	18	2	FQ0007D0
15	23	4.5	6	5	19	2	FQ0008D0
16	24	4.5	6	5	20.3	2	FQ0011D0
18	26	4.5	6	5	22.3	2	FQ0013D0
20	28	4.5	6	5	24	2	FQ0014D0
22.4	30.4	4.5	6	5	26.4	2	FQ0016D0
23.5	31.5	4.5	6	5	27.5	2	FQ0017D0
25	33	4.5	6	5	29	2	FQ0018D0
28	36	4.5	6	5	32	2	FQ0023D0
30	38	5	6.5	6	34	2	FQ0025D0
31.5	39.5	5	6.5	6	35.5	2	FQ0027D0
35	43	5	6.5	6	39	2	FQ0031D0
35.5	43.5	5	6.5	6	39.5	2	FQ0034D0
40	48	5	6.5	6	44	2	FQ0035D0
45	53	5	6.5	6	49	2	FQ0039D0
45.5	53.5	5	6.5	6	49.5	2	FQ0864D0
50	58	5	6.5	6	54	2	FQ0041D0
53	61	5	6.5	6	57	2	FQ0044D0
54.5	62.5	5	6.5	6	58.5	2	FQ0857D0
55	63	5	6.5	6	59	2	FQ0045D0
56	64	5	6.5	6	60	2	FQ0048D0
60	68	5	6.5	6	64	2	FQ0049D0
62	70	5	6.5	6	66	2	FQ0856D0
63	71	5	6.5	6	67	2	FQ0054D0
65	73	5	6.5	6	69	2	FQ0057D0
67	75	5	6.5	6	71	2	FQ0058D0
70	80	6	8	7	75	3	FQ0059D0
71	81	6	8	7	76	3	FQ0062D0
75	85	6	8	7	80	3	FQ0063D0
76	86	6	8	7	81	3	FQ0250D0
80	90	6	8	7	85	3	FQ0064D0
85	95	6	8	7	90	3	FQ0066D0
90	100	6	8	7	95	3	FQ0070D0
95	105	6	8	7	100	3	FQ0071D0
97	107	6	8	7	102	3	FQ0251D0
100	110	6	8	7	105	3	FQ0072D0

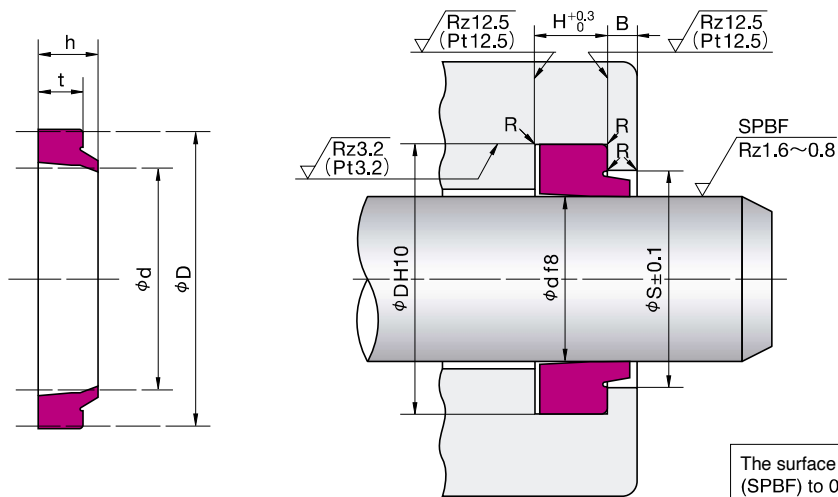

R = 0.3 or below

The surface of the rod should be finished by buffing (SPBF) to 0,8 to 1,6μmRz (0,2 to 0,4μmRa).

- The roughness is JIS B 0601 : 2001.
When regulation length cannot be kept, apply Pt.

Nominal Size of Dust Seal, and Housing dimensions							NOK Part Number
d	D	t	h	H	φS	B	
105	115	6	8	7	110	3	FQ0075D0
106	116	6	8	7	111	3	FQ0078D0
110	120	6	8	7	115	3	FQ0079D0
112	122	6	8	7	117	4	FQ0082D0
118	128	6	8	7	123	4	FQ0085D0
120	130	6	8	7	125	4	FQ0087D0
125	138	7	9.5	8	132	4	FQ0091D0
130	143	7	9.5	8	137	4	FQ0093D0
132	145	7	9.5	8	139	4	FQ0095D0
140	153	7	9.5	8	147	4	FQ0097D0
145	158	7	9.5	8	152	4	FQ0099D0
150	163	7	9.5	8	157	4	FQ0101D0
155	168	7	9.5	8	162	4	FQ0103D0
160	173	7	9.5	8	167	4	FQ0105D0
170	183	7	9.5	8	177	4	FQ0106D0
175	188	7	9.5	8	182	4	FQ0108D0
180	193	7	9.5	8	187	4	FQ0111D0
185	198	7	9.5	8	192	5	FQ0114D0
190	203	7	9.5	8	197	5	FQ0115D0
199	212	7	9.5	8	206	5	FQ0116D0
200	213	7	9.5	8	207	5	FQ0117D0
204	217	7	9.5	8	211	5	FQ0119D0
210	223	7	9.5	8	217	5	FQ0120D0
215	228	7	9.5	8	222	5	FQ0408D1
220	233	7	9.5	8	227	5	FQ0123D0
224	237	7	9.5	8	231	5	FQ0124D0
225	238	7	9.5	8	232	5	FQ0125D0
230	243	7	9.5	8	237	5	FQ0127D0
240	253	7	9.5	8	247	5	FQ0129D0
250	263	7	9.5	8	257	5	FQ0130D0
260	275	9	12	10	268	5	FQ0134D0
270	285	9	12	10	278	5	FQ0135D0
280	295	9	12	10	288	5	FQ0136D0
290	305	9	12	10	298	5	FQ0138D0
300	315	9	12	10	308	5	FQ0139D0

E DIMENSION DSI

LBI TYPE

DUST SEALS FOR
RECIPROCAL MOVEMENT
IRON RUBBER (PUR)



E
DIMENSION
L
B
I

- Please designate NOK Part number and type & size on your order.

(Example) • Type Dimensions

LBI 18 26 4.5 6

└── Type Sign

└── Nominal Size of Dust Seal
described in order of

inner diameter(d), outer diameter(D), thickness(t), and height(h)

• Part Number

FQ0013C0

- Please check the application range on pages 20 and 21 before selecting the type.

Material	NOK U593
-----------------	----------

LBI TYPE DUST SEALS FOR RECIPROCAL MOVEMENT (INSTALLED WITH INTERNAL GROOVE)

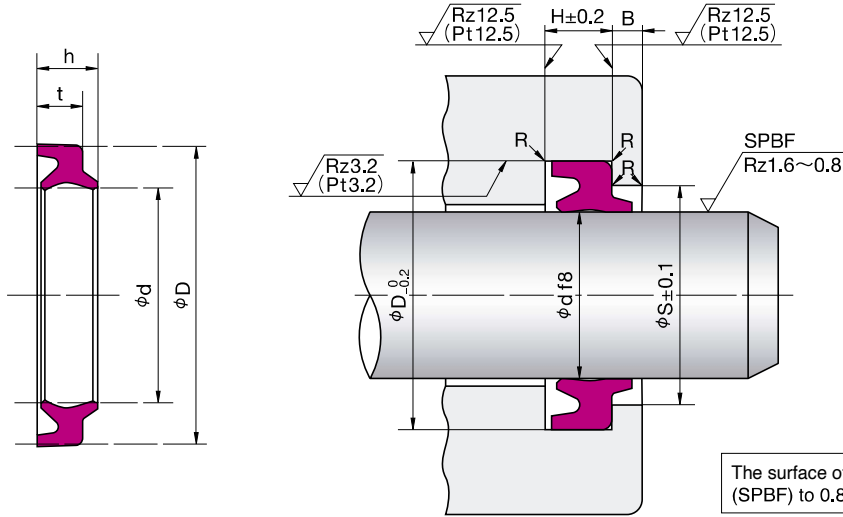

R = 0.3 or below

The surface of the rod should be finished by buffing (SPBF) to 0.8 to 1.6μmRz (0.2 to 0.4μmRa).

● The roughness is JIS B 0601 : 2001.
When regulation length cannot be kept, apply Pt.

Nominal Size of Dust Seal, and Housing dimensions							NOK Part Number
d	D	t	h	H	φS	B	
18	26	4.5	6	5	22.3	2	FQ0013C0
20	28	4.5	6	5	24.3	2	FQ0014C0
22	30	4.5	6	5	26.3	2	FQ0651C0
22.4	30.4	4.5	6	5	26.7	2	FQ0016C0
25	33	4.5	6	5	29.3	2	FQ0018C0
26	34	4.5	6	5	30.3	2	FQ0841C0
28	36	4.5	6	5	32.3	2	FQ0023C0
30	38	5	6.5	6	34	2	FQ0025C1
31.5	39.5	5	6.5	6	35.5	2	FQ0027C0
32	40	5	6.5	6	36	2	FQ0568C1
34	42	5	6.5	6	38	2	FQ0285C0
35	43	5	6.5	6	39	2	FQ0031C1
35.5	43.5	5	6.5	6	39.5	2	FQ0034C0
38	46	5	6.5	6	42	2	FQ0281C1
40	48	5	6.5	6	44	2	FQ0035C1
45	53	5	6.5	6	49	2	FQ0039C1
48	56	5	6.5	6	52	2	FQ0272C0
50	58	5	6.5	6	54	2	FQ0041C0
55	63	5	6.5	6	59	2	FQ0045C1
56	64	5	6.5	6	60	2	FQ0048C1
58	66	5	6.5	6	62	2	FQ0286C0
60	68	5	6.5	6	64	2	FQ0049C1
63	71	5	6.5	6	67	2	FQ0054C0
65	73	5	6.5	6	69	2	FQ0057C1
70	80	6	8	7	75	3	FQ0059C0
71	81	6	8	7	76	3	FQ0062C0
75	85	6	8	7	80	3	FQ0063C0
80	90	6	8	7	85	3	FQ0064C0
85	95	6	8	7	90	3	FQ0066C0
90	100	6	8	7	95	3	FQ0070C0
95	105	6	8	7	100	3	FQ0071C0
100	110	6	8	7	105	3	FQ0072C0
105	115	6	8	7	110	3	FQ0075C0
110	120	6	8	7	115	3	FQ0079C1
112	122	6	8	7	117	3	FQ0082C0
125	138	7	9.5	8	132	3	FQ0091C0
140	153	7	9.5	8	147	3	FQ0097C0
150	163	7	9.5	8	157	3	FQ0101C0
160	173	7	9.5	8	167	3	FQ0105C2
180	193	7	9.5	8	187	3	FQ0111C0
185	198	7	9.5	8	192	3	FQ0114C0
200	213	7	9.5	8	207	3	FQ0117C0
210	223	7	9.5	8	217	3	FQ0120C0
250	265	9	11.5	10	258	3	FQ0131C0

E DIMENSION LBI

LBH TYPE DUST SEALS (INSTALLED WITH INTERNAL GROOVE)

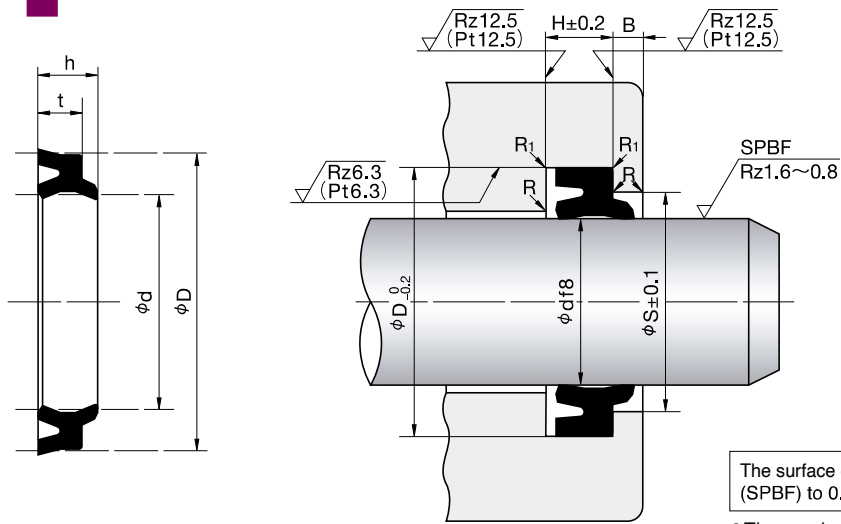

R = 0.3 or below
R₁ = 0.5 or below

The surface of the rod should be finished by buffing (SPBF) to 0.8 to 1.6μmRz (0.2 to 0.4μmRa).

● The roughness is JIS B 0601 : 2001.
When regulation length cannot be kept, apply Pt.

Nominal Size of Dust Seal, and Housing dimensions							Standard (A505)		Heat resistant (F357)	
d	D	t	h	H	φS	B	NOK Part Number	Nominal Number	NOK Part Number	Nominal Number
12	20	4.5	6	5	16.3	2	CL0480C0	LBH-12		
12.5	20.5	4.5	6	5	16.8	2	CL0447C1	LBH-12.5		
14	22	4.5	6	5	18.3	2	CL0432C0	LBH-14		
16	24	4.5	6	5	20.3	2	CL0293C0	LBH-16	CL0293C3	LBH-16F
18	26	4.5	6	5	22.3	2	CL0011C0	LBH-18	CL0011C6	LBH-18F
20	28	4.5	6	5	24.3	2	CL0017C0	LBH-20	CL0017C4	LBH-20F
22	30	4.5	6	5	26.3	2	CL0240C0	LBH-22	CL0240C3	LBH-22F
22.4	30.4	4.5	6	5	26.7	2	CL0026C3	LBH-22.4	CL0026C6	LBH-22.4F
25	33	4.5	6	5	29.3	2	CL0031C0	LBH-25	CL0031C2	LBH-25F
28	36	4.5	6	5	32.3	2	CL0042C0	LBH-28	CL0042C4	LBH-28F
30	38	5	6.5	6	34	2	CL0050C0	LBH-30	CL0050C3	LBH-30F
31.5	39.5	5	6.5	6	35.5	2	CL0054C0	LBH-31.5	CL0054C3	LBH-31.5F
32	40	5	6.5	6	36	2	CL0363C0	LBH-32	CL0363C3	LBH-32F
35	43	5	6.5	6	39	2	CL0066C1	LBH-35	CL0066C4	LBH-35F
35.5	43.5	5	6.5	6	39.5	2	CL0072C0	LBH-35.5	CL0072C4	LBH-35.5F
36	44	5	6.5	6	40	2	CL0335C1	LBH-36		
40	48	5	6.5	6	44	2	CL0077C2	LBH-40	CL0077C4	LBH-40F
45	53	5	6.5	6	49	2	CL0085C0	LBH-45	CL0085C4	LBH-45F
50	58	5	6.5	6	54	2	CL0087C3	LBH-50	CL0087C5	LBH-50F
53	61	5	6.5	6	57	2	CL0100C0	LBH-53	CL0100C2	LBH-53F
55	63	5	6.5	6	59	2	CL0104C0	LBH-55	CL0104C2	LBH-55F
56	64	5	6.5	6	60	2	CL0105C1	LBH-56	CL0105C4	LBH-56F
60	68	5	6.5	6	64	2	CL0107C0	LBH-60	CL0107C2	LBH-60F
63	71	5	6.5	6	67	2	CL0109C1	LBH-63	CL0109C3	LBH-63F
65	73	5	6.5	6	69	2	CL0115C0	LBH-65	CL0115C2	LBH-65F
67	75	5	6.5	6	71	2	CL0118C1	LBH-67	CL0118C2	LBH-67F
70	80	6	8	7	75	3	CL0121C0	LBH-70	CL0121C3	LBH-70F
71	81	6	8	7	76	3	CL0125C0	LBH-71	CL0125C2	LBH-71F
75	85	6	8	7	80	3	CL0127C0	LBH-75	CL0127C2	LBH-75F
80	90	6	8	7	85	3	CL0138C1	LBH-80	CL0138C3	LBH-80F
85	95	6	8	7	90	3	CL0142C0	LBH-85	CL0142C3	LBH-85F
90	100	6	8	7	95	3	CL0149C0	LBH-90	CL0149C4	LBH-90F
95	105	6	8	7	100	3	CL0152C0	LBH-95	CL0152C3	LBH-95F
100	110	6	8	7	105	3	CL0154C2	LBH-100	CL0154C4	LBH-100F

Remark) The Part number and the one stamped on the product might be different in case of heat resistant type.

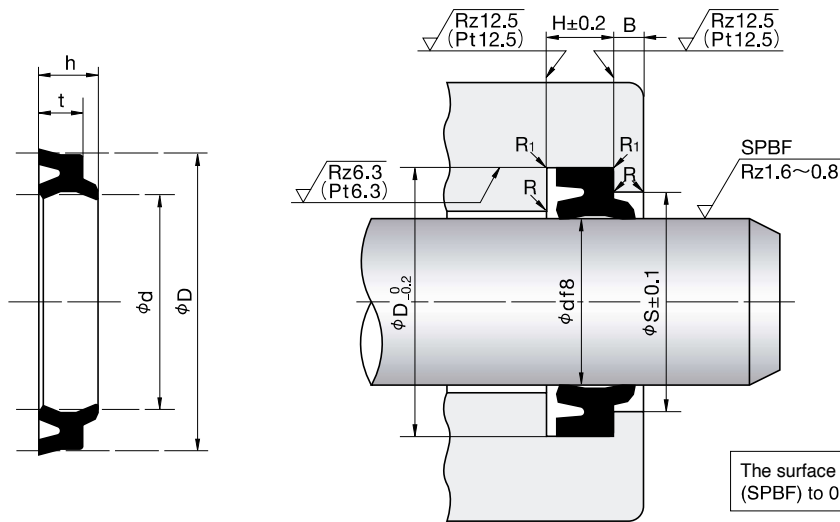

Nominal Size of Dust Seal, and Housing dimensions							Standard (A505)		Heat resistant (F357)	
d	D	t	h	H	φS	B	NOK Part Number	Nominal Number	NOK Part Number	Nominal Number
105	115	6	8	7	110	3	CL0476C0	LBH-105		
106	116	6	8	7	111	3	CL0162C0	LBH-106		
110	120	6	8	7	115	3	CL0448C0	LBH-110	CL0448C2	LBH-110F
112	122	6	8	7	117	3	CL0166C2	LBH-112	CL0166C3	LBH-112F
115	125	6	8	7	120	3	CL0478C0	LBH-115		
118	128	6	8	7	123	3	CL0466C0	LBH-118		
120	133	7	9.5	8	127	3	CL0245C1	LBH-120		
125	138	7	9.5	8	132	3	CL0171C0	LBH-125	CL0171C3	LBH-125F
132	145	7	9.5	8	139	3	CL0174C0	LBH-132		
140	153	7	9.5	8	147	3	CL0179C1	LBH-140	CL0179C4	LBH-140F
145	158	7	9.5	8	152	3	CL0182C0	LBH-145	CL0182C1	LBH-145F
150	163	7	9.5	8	157	3	CL0185C0	LBH-150	CL0185C1	LBH-150F
155	168	7	9.5	8	162	3	CL0486C0	LBH-155		
160	173	7	9.5	8	167	3	CL0188C1	LBH-160	CL0188C3	LBH-160F
160	174	7	9.5	8	167	3	CL0487C0	LBH-160A		
165	178	7	9.5	8	172	3	CL0190C0	LBH-165		
170	183	7	9.5	8	177	3	CL0488C0	LBH-170		
170	185	11	14	12	178	5	CL0191C0	LBH-170A		
175	188	7	9.5	8	182	3	CL0193C0	LBH-175		
180	193	7	9.5	8	187	3	CL0196C1	LBH-180	CL0196C4	LBH-180F
180	194	7	9.5	8	187	3	CL0489C0	LBH-180A		
190	203	7	9.5	8	197	3	CL0490C0	LBH-190		
200	213	7	9.5	8	207	3	CL0199C1	LBH-200	CL0199C3	LBH-200F
205	218	7	9.5	8	212	3	CL0446C0	LBH-205		
210	223	7	9.5	8	217	3	CL0324C1	LBH-210		
224	237	7	9.5	8	231	3	CL0204C1	LBH-224	CL0204C2	LBH-224F
240	256	10	13	11	248	4	CL0300C0	LBH-240		
250	266	9	12	10	258	4	CL0207C0	LBH-250A		
250	266	10	13	11	258	4	CL0267C0	LBH-250		
280	296	9	12	10	288	4	CL0212C0	LBH-280A	CL0212C2	LBH-280AF
355	371	10	13	11	363	4	CL0532C0	LBH-355		
355	375	10	14	11	365	5	CL0301C0	LBH-355A		
400	416	10	13	11	408	4	CL0529C0	LBH-400		
500	520	11.5	15.5	12.5	510	5	CL0460C0	LBH-500		

Remark) The Part number and the one stamped on the product might be different in case of heat resistant type.

E DIMENSION LBH

LBHK_{TYPE}

DUST SEALS
NITRILE RUBBER (NBR)



E
DIMENSION
LBHK

- Please designate NOK Part number and type & size on your order.

(Example) · Type Dimensions LBHK 14 24 4.8 6.7

└── Type Sign

└── Nominal Size of Dust Seal
described in order of
inner diameter(d), outer diameter(D), thickness(t), and height(h)

· Part Number CL0533C0

- Please check the application range on pages 20 and 21 before selecting the type.

Material	Standard : NOK A505 Cold resistant type : NOK A567
-----------------	---

LBHK TYPE DUST SEALS (INSTALLED WITH INTERNAL GROOVE)

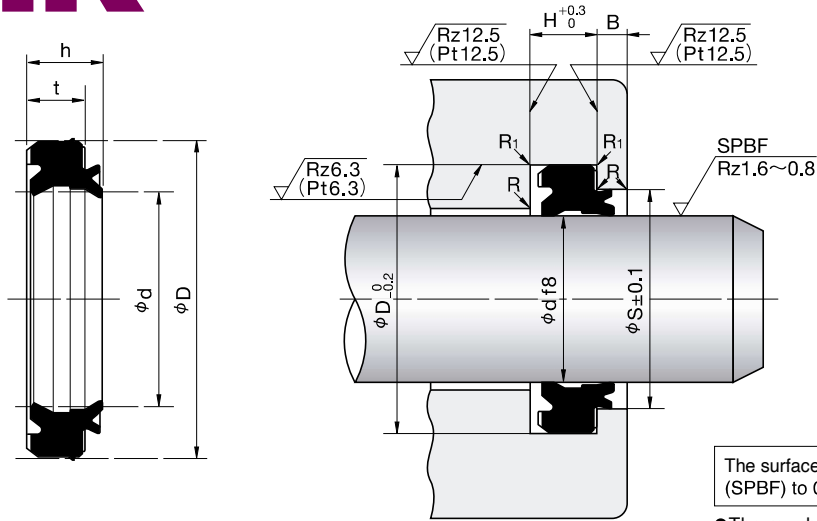

R = 0.3 or below
R₁ = 0.5 or below

The surface of the rod should be finished by buffing (SPBF) to 0.8 to 1.6μmRz (0.2 to 0.4μmRa).

● The roughness is JIS B 0601 : 2001.
When regulation length cannot be kept, apply Pt.

Nominal Size of Dust Seal, and Housing dimensions							NOK Part Number	
d	D	t	h	H	φS	B	Standard (A505)	Cold resistant (A567)
14	24	4.8	6.7	5	19	3	CL0533C0	CL0533C1
18	30	5.8	7.8	6	24	3	CL0534C0	CL0534C1
20	32	5.8	7.8	6	26	3	CL0535C0	CL0535C1
25	37	5.8	7.8	6	31	3	CL0536C0	CL0536C1
28	40	5.8	7.8	6	34	3	CL0537C0	CL0537C1
30	42	5.8	7.8	6	36	3	CL0531C1	CL0531C0
31.5	44	6.8	8.8	7	38	3	CL0538C0	CL0538C1
35	47	6.8	8.8	7	41	3	CL0527C0	CL0527C1
35.5	47.5	6.8	8.8	7	41.5	3	CL0539C0	CL0539C1
40	52	6.8	8.8	7	46	3	CL0540C0	CL0540C1
45	57	6.8	8.8	7	51	3	CL0541C0	CL0541C1
50	62	6.8	8.8	7	56	3	CL0542C0	CL0542C1
55	69	7.7	10	8	62	3	CL0543C0	CL0543C1
56	70	7.7	10	8	63	3	CL0544C0	CL0544C1
60	74	7.7	10	8	67	3	CL0518C1	CL0518C2
63	77	7.7	10	8	70	3	CL0545C0	CL0545C1
65	79	7.7	10	8	72	3	CL0546C0	CL0546C1
70	84	7.7	10	8	77	3	CL0547C0	CL0547C1
71	85	7.7	10	8	78	3	CL0548C0	CL0548C1
75	89	7.7	10	8	82	3	CL0549C0	CL0549C1
80	94	7.7	10	8	87	3	CL0519C1	CL0519C2
85	99	7.7	10	8	92	3	CL0550C0	CL0550C1
90	104	7.7	10	8	97	3	CL0551C0	CL0551C1
95	109	7.7	10	8	102	3	CL0552C0	CL0552C1
100	114	7.7	10	8	107	3	CL0553C0	CL0553C1
105	121	8.7	11.4	9	113	4	CL0554C0	CL0554C1
106	120	7.7	10	8	113	3	CL0555C0	CL0555C1
110	126	8.7	11.4	9	118	4	CL0556C0	CL0556C1
112	128	8.7	11.4	9	120	4	CL0557C0	CL0557C1
115	131	8.7	11.4	9	123	4	CL0558C0	CL0558C1
118	134	8.7	11.4	9	126	4	CL0559C0	CL0559C1
120	136	8.7	11.4	9	128	4	CL0560C0	CL0560C1

Remark) The Part number and the one stamped on the product might be different in case of heat resistant type.

E DIMENSION LBHK

E
DIMENSION
L
B
H
K

DSPB^{TYPE} SPECIAL PACKINGS FOR DUST SEALS

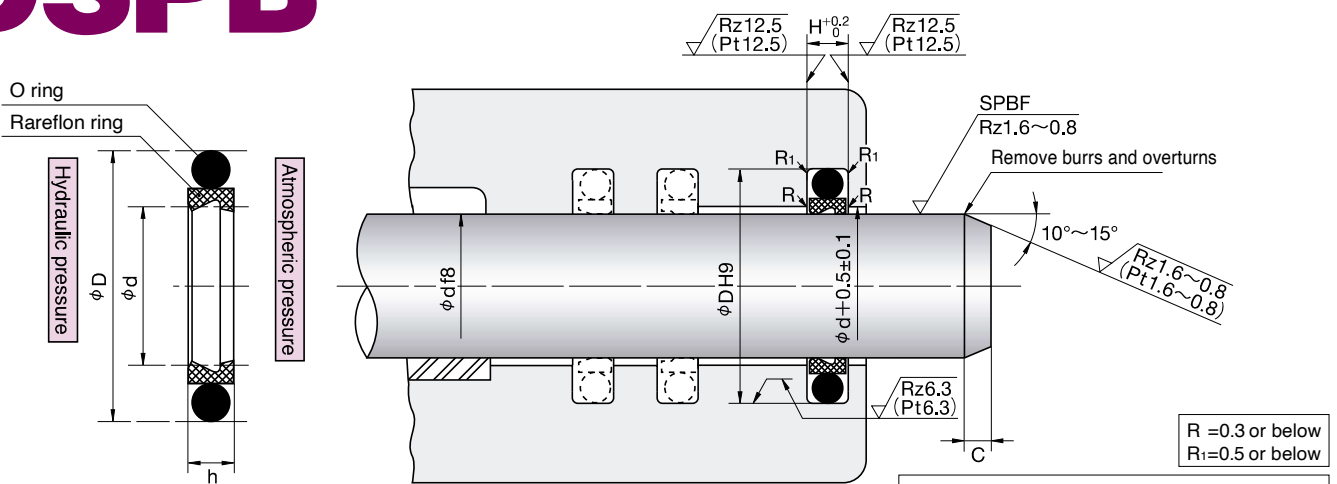

The surface of the rod should be finished by buffing (SPBF) to 0.8 to 1.6μmRz (0.2 to 0.4μmRa).

- The roughness is JIS B 0601 : 2001.
- When regulation length cannot be kept, apply Pt.

Nominal Number	Nominal Size of Dust Seal, and Housing dimensions					NOK Part Number
	d	D	h	H	C	
DSPB 4	4	8.9	2.1	2.2	3.5	● GS5500V0
5	5	9.9	2.1	2.2	3.5	● GS5501V0
6	6	10.9	2.1	2.2	3.5	● GS5502V0
7	7	11.9	2.1	2.2	3.5	● GS5503V0
8S	8	12.9	2.1	2.2	3.5	● GS5504V0
8	8	15.3	3.1	3.2	3.5	● GS5505V0
10S	10	14.9	2.1	2.2	3.5	● GS5506V0
10	10	17.3	3.1	3.2	3.5	● GS5507V0
12S	12	16.9	2.1	2.2	4.5	● GS5508V0
12	12	19.3	3.1	3.2	4.5	● GS5509V0
14S	14	18.9	2.1	2.2	4.5	● GS5510V0
14	14	21.3	3.1	3.2	4.5	● GS5511V0
15S	15	19.9	2.1	2.2	4.5	● GS5512V0
15	15	22.3	3.1	3.2	4.5	● GS5513V0
16S	16	20.9	2.1	2.2	4.5	● GS5514V0
16	16	23.3	3.1	3.2	4.5	● GS5515V0
18S	18	22.9	2.1	2.2	4.5	● GS5516V0
18	18	25.3	3.1	3.2	4.5	● GS5517V0
20S	20	27.3	3.1	3.2	4.5	● GS5518V0
20	20	30.7	4.1	4.2	4.5	● GS5519V0
22S	22	29.3	3.1	3.2	4.5	● GS5520V0
22	22	32.7	4.1	4.2	4.5	● GS5521V0
22.4S	22.4	29.7	3.1	3.2	4.5	● GS5522V0
22.4	22.4	33.1	4.1	4.2	4.5	● GS5523V0
25S	25	32.3	3.1	3.2	5.5	● GS5524V0
25	25	35.7	4.1	4.2	5.5	● GS5525V0
28S	28	35.3	3.1	3.2	5.5	● GS5526V0
28	28	38.7	4.1	4.2	5.5	● GS5527V0
30S	30	37.3	3.1	3.2	5.5	● GS5528V0
30	30	40.7	4.1	4.2	5.5	● GS5529V0
32S	32	39.3	3.1	3.2	5.5	GS5530V0
32	32	42.7	4.1	4.2	5.5	GS5531V0
35S	35	42.3	3.1	3.2	5.5	GS5532V0
35	35	45.7	4.1	4.2	5.5	GS5533V0
35.5S	35.5	42.8	3.1	3.2	5.5	GS5534V0
35.5	35.5	46.2	4.1	4.2	5.5	GS5535V0
36S	36	43.3	3.1	3.2	5.5	GS5536V0
36	36	46.7	4.1	4.2	5.5	GS5537V0
38S	38	48.7	4.1	4.2	5.5	GS5538V0
38	38	53.1	6.1	6.3	5.5	GS5539V0

Remark) When using the packing with ●, provide separate grooves.

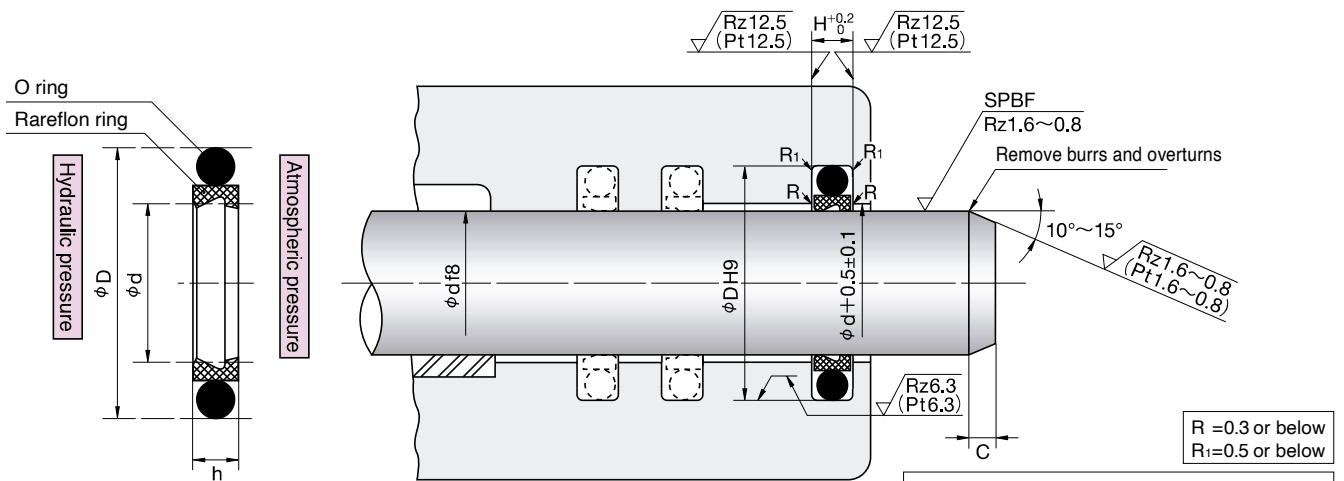

R = 0.3 or below
R₁ = 0.5 or below

The surface of the rod should be finished by buffing (SPBF) to 0.8 to 1.6µmRz (0.2 to 0.4µmRa).

●The roughness is JIS B 0601 : 2001.
When regulation length cannot be kept, apply Pt.

Nominal Number	Nominal Size of Dust Seal, and Housing dimensions					NOK Part Number
	d	D	h	H	C	
DSPB 40S	40	50.7	4.1	4.2	5.5	GS5540V0
40	40	55.1	6.1	6.3	5.5	GS5541V0
42S	42	52.7	4.1	4.2	5.5	GS5542V0
42	42	57.1	6.1	6.3	5.5	GS5543V0
45S	45	55.7	4.1	4.2	5.5	GS5544V0
45	45	60.1	6.1	6.3	5.5	GS5545V0
50S	50	60.7	4.1	4.2	5.5	GS5546V0
50	50	65.1	6.1	6.3	5.5	GS5547V0
56S	56	66.7	4.1	4.2	7	GS5548V0
56	56	71.1	6.1	6.3	7	GS5549V0
60S	60	70.7	4.1	4.2	7	GS5550V0
60	60	75.1	6.1	6.3	7	GS5551V0
63	63	78.1	6.1	6.3	7	GS5552V0
65	65	80.1	6.1	6.3	7	GS5553V0
67	67	82.1	6.1	6.3	7	GS5554V0
70	70	85.1	6.1	6.3	7	GS5555V0
71	71	86.1	6.1	6.3	7	GS5556V0
75	75	90.1	6.1	6.3	7	GS5557V0
80	80	95.1	6.1	6.3	7	GS5558V0
85	85	100.1	6.1	6.3	7	GS5559V0
90	90	105.1	6.1	6.3	7	GS5560V0
95	95	110.1	6.1	6.3	7	GS5561V0
100	100	115.1	6.1	6.3	7	GS5562V0
105	105	120.1	6.1	6.3	7	GS5563V0
110	110	125.1	6.1	6.3	7	GS5564V0
112	112	127.1	6.1	6.3	7	GS5565V0
115	115	130.1	6.1	6.3	7	GS5566V0
120	120	135.1	6.1	6.3	7	GS5567V0
125	125	140.1	6.1	6.3	7	GS5568V0
130	130	145.1	6.1	6.3	7	GS5569V0
135	135	150.1	6.1	6.3	7	GS5570V0
140	140	155.1	6.1	6.3	7	GS5571V0
150	150	165.1	6.1	6.3	7	GS5572V0
160	160	175.1	6.1	6.3	7	GS5573V0
170	170	185.1	6.1	6.3	7	GS5574V0
180	180	195.1	6.1	6.3	7	GS5575V0

E DIMENSION DSPB

DLI TYPE

DUST SEALS FOR OSCILLATING
AND ROTATING MOVEMENT
IRON RUBBER (PUR)



E
DIMENSION
DLI

- Please designate NOK Part number and type & size on your order.

(Example) · Type Dimensions

DLI 40 50 5

Type Sign

Nominal Size of Dust Seal
described in order of
inner diameter(d), outer diameter(D), and height(h)

· Part Number

FD9991E0

- Please check the application range on pages 22 and 23 before selecting the type.

Material	NOK U801 (D=φ50~φ160) NOK U593 (D=φ170~φ280) + Metal case (SPCC)
-----------------	---

DLI TYPE DUST SEALS FOR OSCILLATING MOVEMENT

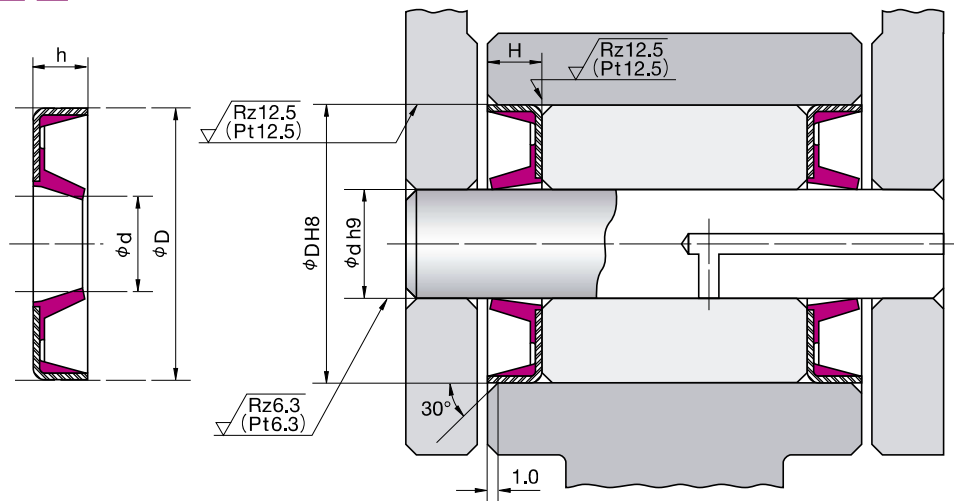

●The roughness is JIS B 0601 : 2001.
When regulation length cannot be kept, apply Pt.

Nominal Size of Dust Seal, and Housing dimensions				NOK Part Number
d	D	h	$H^{+0.5}_{+0.3}$	
40	50	5	5	FD9991E0
50	60	5	5	FD9990E0
55	68	6	6	FD9996E0
60	75	6	6	FD3191F0
Nominal Size of Dust Seal, and Housing dimensions				NOK Part Number
d	D	h	$H^{+0.6}_{+0.4}$	
65	80	8	8	FD9994E0
70	85	8	8	FD9922E0
75	90	8	8	FD3598E0
90	105	8	8	FD3916E0
95	110	8	8	FD3978F0
100	115	8	8	FD6715E0
105	120	8	8	FD4141F0
110	125	8	8	FD9993E0
115	130	8	8	FD9984E0
120	135	8	8	FD9938E0
125	140	8	8	FD9995E0
140	170	10	10	FD9969E0
145	160	8	8	FD6713E0
150	180	11	11	FD9956E0
160	180	8	8	FD6712E0
160	190	8	8	FD6710E0
160	190	13	13	FD4710E0
170	200	13	13	FD4792E0
175	205	8	8	FD6711E0
180	200	8	8	FD6727E0
180	210	13	13	FD6759E0
190	210	8	8	FD6728E0
200	220	8	8	FD6729E0
200	230	8	8	FD6730E0
200	230	13	13	FD6723E0
220	250	13	13	FD9975E0
220	255	14	14	FD6774E0
230	255	14	14	FD6793E0
240	270	13	13	FD6724E0
240	275	14	14	FD6763E0
250	280	13	13	FD6725E0

E DIMENSION DLI

DLI2^{TYPE} DUST SEALS FOR OSCILLATING MOVEMENT

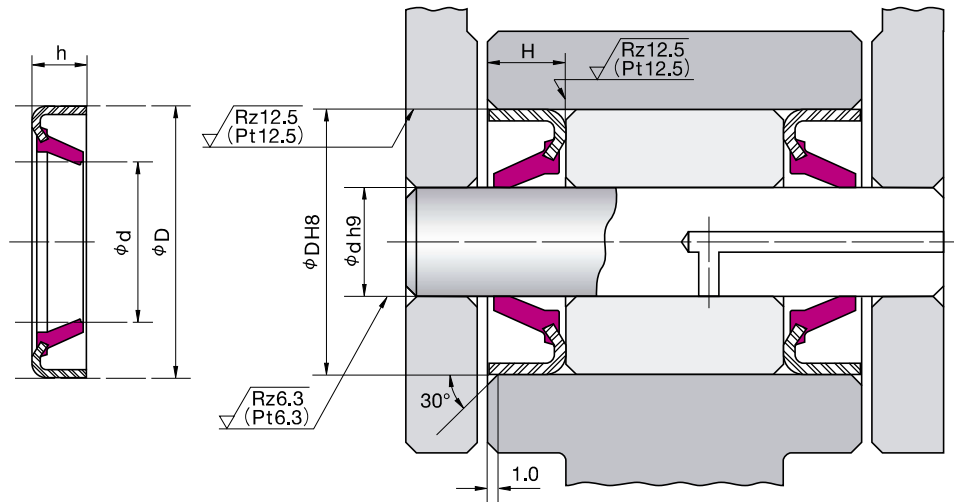

●The roughness is JIS B 0601 : 2001.
When regulation length cannot be kept, apply Pt.

Nominal Size of Dust Seal, and Housing dimensions				NOK Part Number
d	D	h	$H^{+0.5}_{+0.3}$	
35	45	4	4	FD2032G0
40	50	5	5	FD9991E1
50	60	5	5	FD9990E1
55	68	6	6	FD9996E1
Nominal Size of Dust Seal, and Housing dimensions				NOK Part Number
d	D	h	$H^{+0.6}_{+0.4}$	
60	75	8	8	FD3192E1
65	80	8	8	FD9994E1
70	85	8	8	FD9922E1
75	90	8	8	FD3598E1
85	100	8	8	FD9989E1
95	110	8	8	FD3978F1
110	125	8	8	FD9993E1
120	135	8	8	FD9938E1
125	140	8	8	FD9995E1
140	155	8	8	FD6714E1
145	160	8	8	FD6713E1

E
DIMENSION
DLI2

HBY TYPE

BUFFER RING

IRON RUBBER (PUR) +
POLYAMIDE RESIN (PA)



E
DIMENSION
HB
Y

- Please designate NOK Part number and type & size on your order.

(Example) · Type Dimensions HBY 40 55.5 6

└─ Type Sign └─ Nominal Size of Dust Seal
described in order of
inner diameter(d), outer diameter(D), and height(h)

· Part Number FQ0253F3

- Please check the application range on pages 22 and 23 before selecting the type.

Material	Standard : NOK U801 Heat resistant type : NOK U641 + NOK 12NM (d = φ40 ~ φ160) Super heat resistant type : NOK UH05 + NOK 80NP (d = φ170 ~ φ210)
-----------------	--

HB Y TYPE BUFFER RING

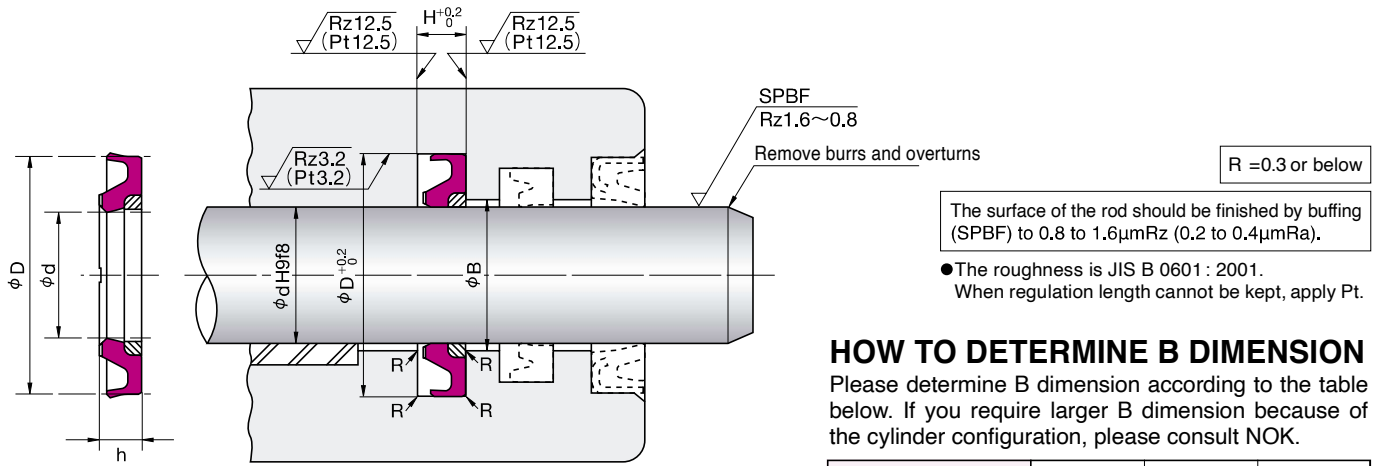

HOW TO DETERMINE B DIMENSION

Please determine B dimension according to the table below. If you require larger B dimension because of the cylinder configuration, please consult NOK.

Maximum Service Pressure	35MPa	42MPa	50MPa
B Dimension	d + 0.8	d + 0.4	d + 0.25

Nominal Size of Buffer Ring, and Housing dimensions				NOK Part Number		
d	D	h	H	Standard (U801)	Heat resistant (U641)	Super heat resistant (UH05)
40	55.5	6	6.3	FQ0253F3	FQ0253F4	
45	60.5	6	6.3	FQ0254F5	FQ0254F6	
50	65.5	6	6.3	FQ0255F4	FQ0255F3	FQ0255F7
55	70.5	6	6.3	FQ0256F4	FQ0256F5	FQ0256F7
60	75.5	6	6.3	FQ0257F4	FQ0257F5	FQ0257F6
65	80.5	6	6.3	FQ0258F4	FQ0258F3	FQ0258F7
70	85.5	6	6.3	FQ0244F5	FQ0244F4	FQ0244F8
75	90.5	6	6.3	FQ0245F5	FQ0245F4	FQ0245F8
80	95.5	6	6.3	FQ0246F6	FQ0246F5	FQ0246F9
85	100.5	6	6.3	FQ0259F5	FQ0259F6	FQ1226F0
90	105.5	6	6.3	FQ0260F6	FQ0260F5	FQ0260F9
95	110.5	6	6.3	FQ0575F6	FQ0575F4	FQ1225F0
100	115.5	6	6.3	FQ0261F7	FQ0261F5	FQ1214F1
105	120.5	6	6.3	FQ0629F6	FQ0629F5	FQ1244F0
110	125.5	6	6.3	FQ0262F6	FQ0262F4	FQ1220F0
115	130.5	6	6.3	FQ0868F5	FQ0868F4	FQ0868F7
120	135.5	6	6.3	FQ0263F4	FQ0263F5	FQ0263F8
125	140.5	6	6.3	FQ0842F3	FQ0842F4	FQ0842F7
130	145.5	6	6.3	FQ0264F5	FQ0264F4	FQ0264F8
132	147.5	6	6.3	FQ0784F2	FQ0784F3	
135	150.5	6	6.3	FQ0904F2	FQ0904F3	
140	155.5	6	6.3	FQ0265F5	FQ0265F4	FQ0265F6
150	165.5	6	6.3	FQ0871F3	FQ0871F4	FQ0871F6
160	175.5	6	6.3	FQ0433F4	FQ0433F5	FQ0433F6
170	185.5	6	6.3	FQ0603F0	FQ0603F1	FQ00603-F6A
180	195.5	6	6.3	FQ0451F0	FQ0451F1	FQ0451F3
190	205.5	6	6.3	FQ0646F0	FQ0646F1	
200	221	7.7	8	FQ0830F0	FQ0830F2	FQ0830F3
210	231	7.7	8	FQ0824F0	FQ0824F2	FQ0824F3

HBTS TYPE BUFFER RING

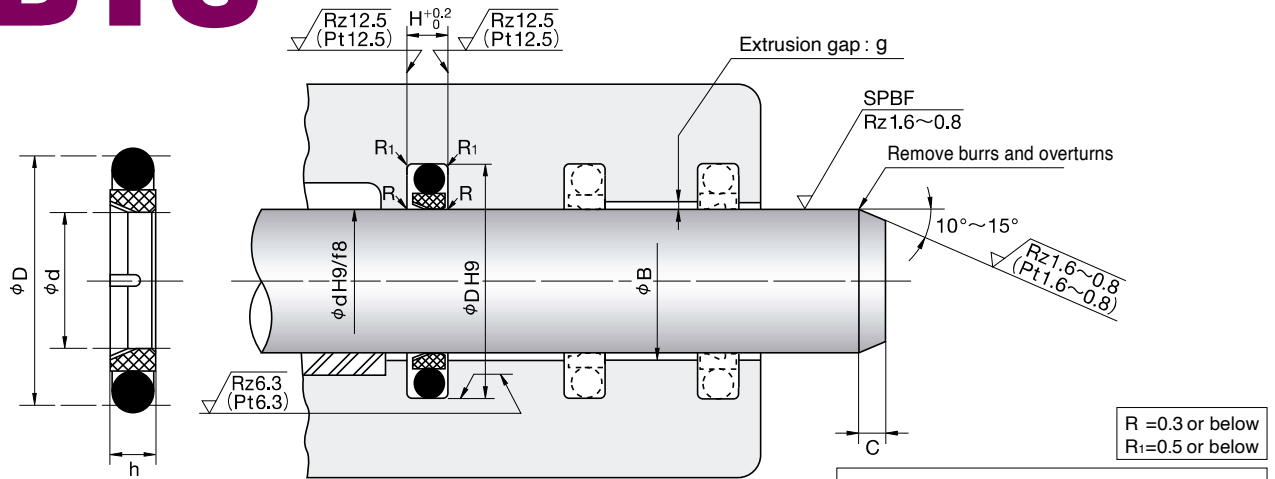

The surface of the rod should be finished by buffing (SPBF) to 0.8 to 1.6 μ mRz (0.2 to 0.4 μ mRa).

● The roughness is JIS B 0601 : 2001.
When regulation length cannot be kept, apply Pt.

Nominal Number	Nominal Size of Buffer Ring, and Housing dimensions				NOK Part Number
	d	D	h	H	
HBTS 4	4	8.9	2	2.2	● GS5000V6
5	5	9.9	2	2.2	● GS5001V6
6	6	10.9	2	2.2	● GS5002V6
7	7	11.9	2	2.2	● GS5003V6
8	8	15.3	2.9	3.2	● GS5005V6
10	10	17.3	2.9	3.2	● GS5007V6
12	12	19.3	2.9	3.2	● GS5009V6
14	14	21.3	2.9	3.2	● GS5011V6
15	15	22.3	2.9	3.2	● GS5013V6
16	16	23.3	2.9	3.2	● GS5015V6
18	18	25.3	2.9	3.2	● GS5017V6
20	20	30.7	3.9	4.2	● GS5019V6
22	22	32.7	3.9	4.2	● GS5021V6
22.4	22.4	33.1	3.9	4.2	● GS5023V6
25	25	35.7	3.9	4.2	● GS5025V6
28	28	38.7	3.9	4.2	● GS5027V6
30	30	40.7	3.9	4.2	● GS5029V6
32	32	42.7	3.9	4.2	GS5031V6
35	35	45.7	3.9	4.2	GS5033V6
35.5	35.5	46.2	3.9	4.2	GS5035V6
36	36	46.7	3.9	4.2	GS5037V6
38	38	53.1	5.9	6.3	GS5039V6
40	40	55.1	5.9	6.3	GS5041V6
42	42	57.1	5.9	6.3	GS5043V6
45	45	60.1	5.9	6.3	GS5045V6
50	50	65.1	5.9	6.3	GS5047V6
56	56	71.1	5.9	6.3	GS5049V6
60	60	75.1	5.9	6.3	GS5051V6
63	63	78.1	5.9	6.3	GS5052V6
65	65	80.1	5.9	6.3	GS5053V6
67	67	82.1	5.9	6.3	GS5054V6
70	70	85.1	5.9	6.3	GS5055V6
71	71	86.1	5.9	6.3	GS5056V6
75	75	90.1	5.9	6.3	GS5057V6
80	80	95.1	5.9	6.3	GS5058V6
85	85	100.1	5.9	6.3	GS5059V6
90	90	105.1	5.9	6.3	GS5060V6
95	95	110.1	5.9	6.3	GS5061V6

Remark) When using the packing with ●, provide separate grooves.

HOW TO DETERMINE B DIMENSION

To determine B dimension, please refer to the graph in the right for the maximum extrusion gap (one side) considering the eccentricity of operating condition of the piston.

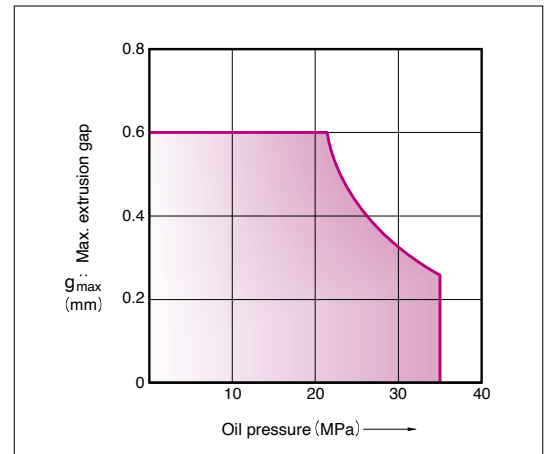

Nominal Number	Nominal Size of Buffer Ring, and Housing dimensions				NOK Part Number
	d	D	h	H	
HBTS 100	100	115.1	5.9	6.3	GS5062V6
105	105	120.1	5.9	6.3	GS5063V6
110	110	125.1	5.9	6.3	GS5064V6
112	112	127.1	5.9	6.3	GS5065V6
115	115	130.1	5.9	6.3	GS5066V6
120	120	135.1	5.9	6.3	GS5067V6
125	125	140.1	5.9	6.3	GS5068V6
130	130	145.1	5.9	6.3	GS5069V6
135	135	150.1	5.9	6.3	GS5070V6
140	140	155.1	5.9	6.3	GS5071V6
150	150	165.1	5.9	6.3	GS5072V6
160	160	175.1	5.9	6.3	GS5073V6
170	170	185.1	5.9	6.3	GS5074V6
180	180	195.1	5.9	6.3	GS5075V6

RYT TYPE

WEAR RING RAREFLON (PTFE)

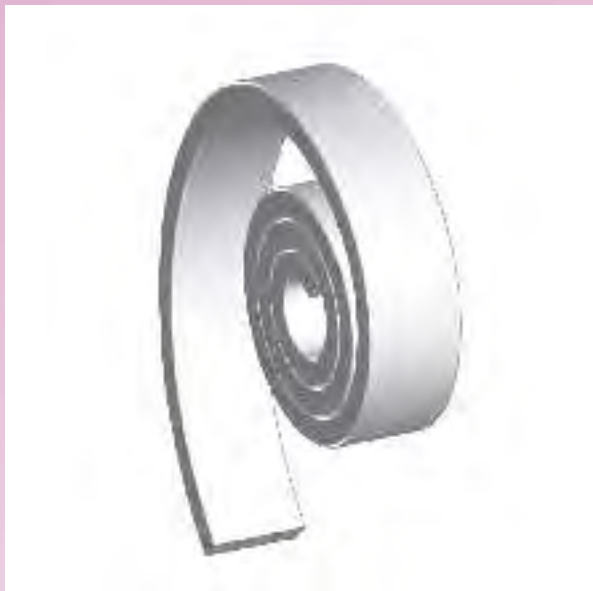

E
DIMENSION
R
Y
T

- Please designate NOK Part number and type & size on your order.

(Example) · Type Dimensions

RYT

2 8

Type Sign

Nominal Size of Wear Ring
described in order of
thickness(t) and height(h)

· Part Number

GZ1291V0

- Please check the application range on pages 22 and 23 before selecting the type.

Material	NOK 05ZF
-----------------	----------

RYT TYPE WEAR RING

Remark) B dimension should be determined according to the packing used.

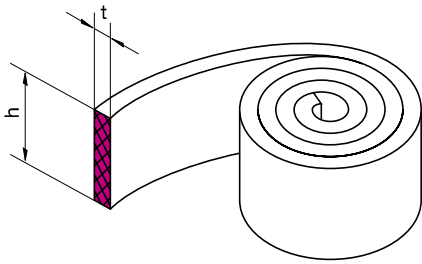

※One roll length is 10 m.

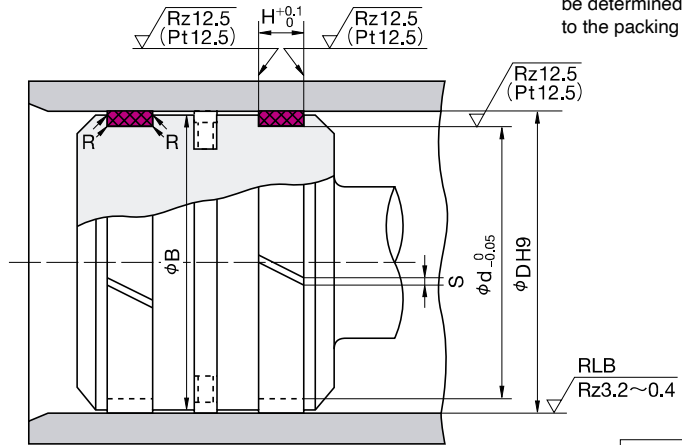

R = 0.3 or below

The inner surface of the cylinder tube should be finished by burnishing (RLB) or honing (GH) to 0.4 to 3.2 μm Rz (0.1 to 0.8 μm Ra). Especially under severe lubricating condition, burnishing is required.

- The roughness is JIS B 0601 : 2001. When regulation length cannot be kept, apply Pt.

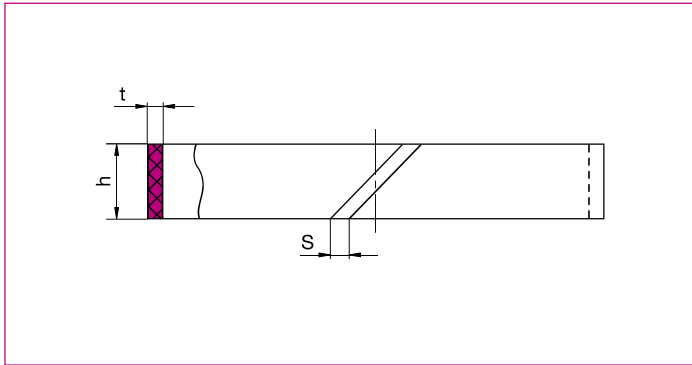

Remark) Determine the length of wear ring = L according to the formula below.

$$L = \pi \cdot (D - t) - S$$

Nominal Number	Nominal Size of Wear Ring			Housing dimensions			NOK Part Number
	t	h	S	φD	φd	H	
RYT 8	2	8	1 ~ 1.5	18 ~ 63	D-4	8	GZ1291V0
10	2	10	1 ~ 2	33 ~ 80	D-4	10	GZ1292V0
15	2.5	15	1.5 ~ 3	41 ~ 130	D-5	15	GZ1293V0
20	2.5	20	2 ~ 4	65 ~ 160	D-5	20	GZ1294V0
25	2.5	25	2 ~ 6	85 ~ 225	D-5	25	GZ1295V0
30	2.5	30	3 ~ 6.5	112 ~ 250	D-5	30	GZ1296V0
35	2.5	35	3.5 ~ 8	132 ~ 300	D-5	35	GZ1297V0
40	2.5	40	4 ~ 9	150 ~ 350	D-5	40	GZ1298V0
45	2.5	45	4 ~ 10	165 ~ 400	D-5	45	GZ1299V0
50	3	50	5 ~ 11	205 ~ 450	D-6	50	GZ1300V0
55	3	55	6 ~ 13	230 ~ 500	D-6	55	GZ1301V0
60	3	60	7 ~ 15	260 ~ 600	D-6	60	GZ1302V0
70	3	70	8 ~ 28	290 ~ 1000	D-6	70	GZ1303V0

※ RYT type wear ring of other dimensions than the above can be available on demand, please consult NOK.

E DIMENSION RYT

WR TYPE WEAR RING (FOR U TYPE PACKINGS)

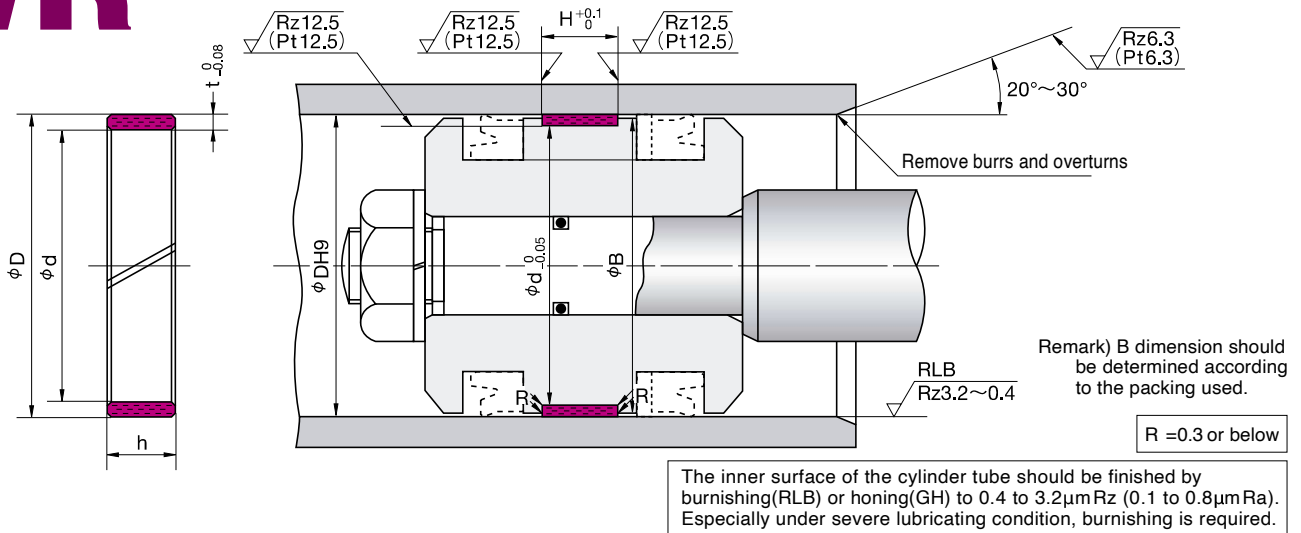

●The roughness is JIS B 0601 : 2001.
When regulation length cannot be kept, apply Pt.

Nominal Number	Nominal Size of Wear Ring, and Housing dimensions					NOK Part Number
	d	D	h	t	H	
WR 18	14	18	8	2	8	GW0241P0
19.2	15.2	19.2	8	2	8	GW0242P0
20	16	20	8	2	8	GW0243P0
22	18	22	8	2	8	GW0244P0
24	20	24	8	2	8	GW0245P0
25	21	25	8	2	8	GW0246P0
26	22	26	8	2	8	GW0247P0
28	24	28	8	2	8	GW0248P0
30	26	30	8	2	8	GW0249P0
31	27	31	8	2	8	GW0250P0
31.5	27.5	31.5	8	2	8	GW0251P0
33	29	33	10	2	10	GW0252P0
35	31	35	10	2	10	GW0253P0
35.4	31.4	35.4	10	2	10	GW0254P0
35.5	31.5	35.5	10	2	10	GW0255P0
38	34	38	10	2	10	GW0256P0
40	36	40	10	2	10	GW0257P0
41	37	41	15	2	15	GW0258P0
43	38	43	15	2.5	15	GW0259P0
44.5	39.5	44.5	15	2.5	15	GW0260P0
45	40	45	15	2.5	15	GW0261P0
50	45	50	15	2.5	15	GW0006P1
51.5	46.5	51.5	15	2.5	15	GW0263P0
55	50	55	15	2.5	15	GW0264P0
56	51	56	15	2.5	15	GW0010P1
60	55	60	15	2.5	15	GW0012P1
61	56	61	15	2.5	15	GW0267P0
63	58	63	15	2.5	15	GW0268P0
65	60	65	20	2.5	20	GW0269P0
66	61	66	20	2.5	20	GW0270P0
69	64	69	20	2.5	20	GW0271P0
70	65	70	20	2.5	20	GW0019P1
71	66	71	20	2.5	20	GW0192P1
75	70	75	20	2.5	20	GW0021P1
76	71	76	20	2.5	20	GW0746P0
80	75	80	20	2.5	20	GW0027P1

E DIMENSION WR

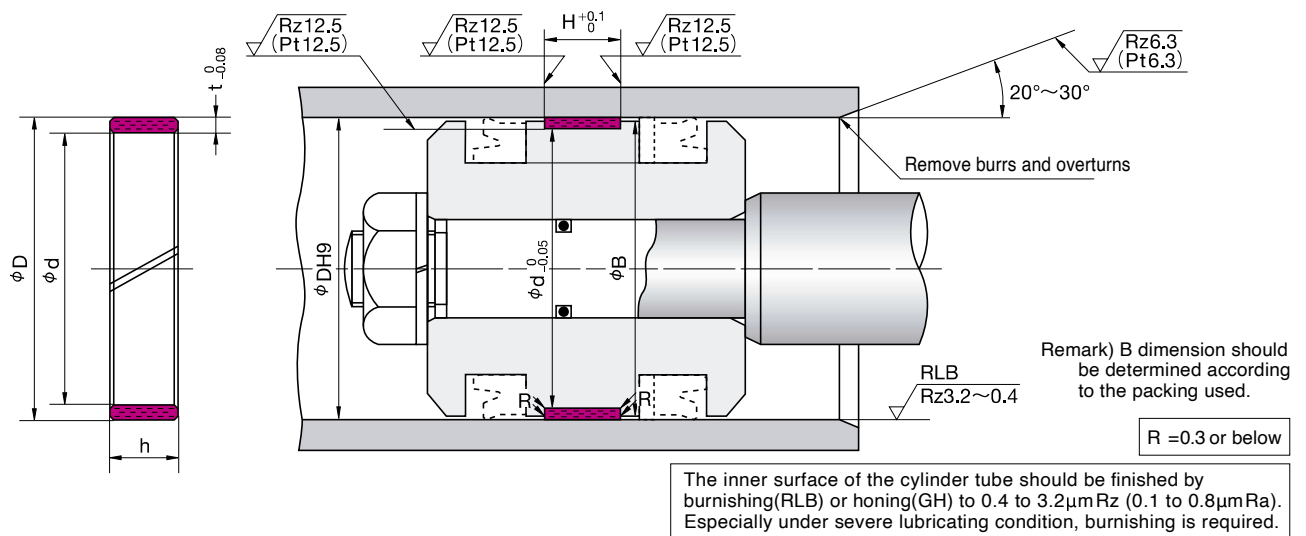

●The roughness is JIS B 0601 : 2001.
When regulation length cannot be kept, apply Pt.

Nominal Number	Nominal Size of Wear Ring, and Housing dimensions					NOK Part Number
	d	D	h	t	H	
WR 85	79	85	25	3	25	GW0030P1
90	84	90	25	3	25	GW0036P1
95	89	95	25	3	25	GW0167P1
100	94	100	25	3	25	GW0041P3
105	99	105	25	3	25	GW0278P0
110	104	110	25	3	25	GW0051P1
112	106	112	30	3	30	GW0280P0
115	109	115	30	3	30	GW0055P2
120	114	120	30	3	30	GW0059P1
125	119	125	30	3	30	GW0283P0
130	123	130	30	3.5	30	GW0065P1
132	125	132	35	3.5	35	GW0285P0
140	133	140	35	3.5	35	GW0075P1
150	143	150	35	3.5	35	GW0086P1
157	150	157	40	3.5	40	GW0287P0
160	153	160	40	3.5	40	GW0093P2
165	157	165	45	4	45	GW0289P0
170	162	170	45	4	45	GW0290P0
180	172	180	45	4	45	GW0104P1
185	177	185	45	4	45	GW0292P0
190	182	190	45	4	45	GW0293P0
200	192	200	45	4	45	GW0109P1
205	197	205	50	4	50	GW0181P1
210	202	210	50	4	50	GW0296P0
220	212	220	50	4	50	GW0297P0
224	216	224	50	4	50	GW0298P0
225	217	225	50	4	50	GW0115P1
230	222	230	55	4	55	GW0300P0
240	232	240	55	4	55	GW0301P0
250	242	250	55	4	55	GW0122P1
260	252	260	60	4	60	GW0303P0
270	262	270	60	4	60	GW0304P0
275	267	275	60	4	60	GW0305P0
290	282	290	70	4	70	GW0307P0
297	289	297	70	4	70	GW0308P0
300	292	300	70	4	70	GW0309P0
312	304	312	70	4	70	GW0310P0
332	324	332	70	4	70	GW0311P0

E DIMENSION
WR

WR TYPE

WEAR RING (FOR PACKINGS OF SPG AND SPGW TYPE)

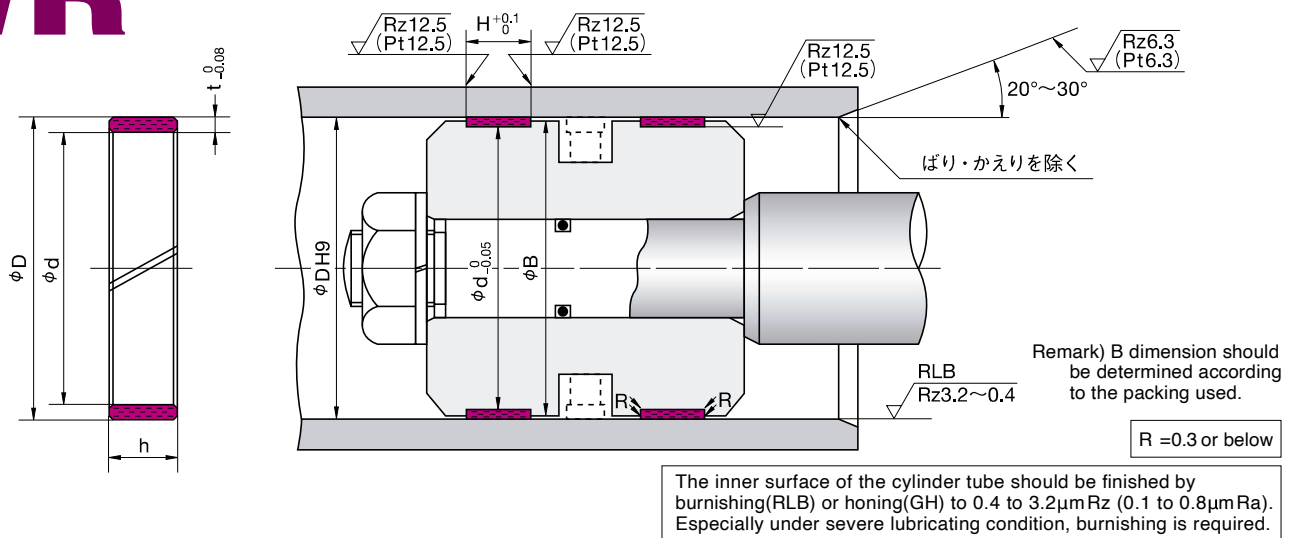

Nominal Number	Nominal Size of Wear Ring, and Housing dimensions					NOK Part Number
	d	D	h	t	H	
WR 30W	26	30	8	2	8	GW0249P0
31.5W	27.5	31.5	8	2	8	GW0251P0
32W	28	32	8	2	8	GW0314P0
35W	31	35	8	2	8	GW0315P0
35.5W	31.5	35.5	8	2	8	GW0316P0
40W	36	40	8	2	8	GW0317P0
45W	40	45	8	2.5	8	GW0318P0
50W	45	50	8	2.5	8	GW0279P0
55W	50	55	8	2.5	8	GW0319P0
56W	51	56	8	2.5	8	GW0320P0
60W	55	60	8	2.5	8	GW0321P0
63W	58	63	8	2.5	8	GW0322P0
65W	60	65	10	2.5	10	GW0323P0
69W	64	69	10	2.5	10	GW0324P0
70W	65	70	10	2.5	10	GW0018P1
71W	66	71	10	2.5	10	GW0326P0
75W	70	75	10	2.5	10	GW0327P0
80W	75	80	10	2.5	10	GW0025P1
85W	79	85	15	3	15	GW0329P0
90W	84	90	15	3	15	GW0330P0
95W	89	95	15	3	15	GW0331P0
100W	94	100	15	3	15	GW0332P0
108W	102	108	15	3	15	GW0333P0
110W	104	110	15	3	15	GW0334P0
112W	106	112	15	3	15	GW0335P0
120W	114	120	15	3	15	GW0336P0
125W	119	125	15	3	15	GW0337P0
130W	123	130	15	3.5	15	GW0338P0
140W	133	140	20	3.5	20	GW0339P0
150W	143	150	20	3.5	20	GW0340P0
160W	153	160	20	3.5	20	GW0341P0
170W	162	170	25	4	25	GW0342P0
180W	172	180	25	4	25	GW0343P0
190W	182	190	25	4	25	GW0344P0
200W	192	200	25	4	25	GW0345P0
204W	196	204	25	4	25	GW0346P0
210W	202	210	25	4	25	GW0347P0
224W	216	224	25	4	25	GW0348P0
225W	217	225	25	4	25	GW0349P0
230W	222	230	30	4	30	GW0350P0
240W	232	240	30	4	30	GW0351P0
250W	242	250	30	4	30	GW0352P0

E DIMENSION WR

WR TYPE WEAR RING (COMBINED PISTON/ROD)

For rod

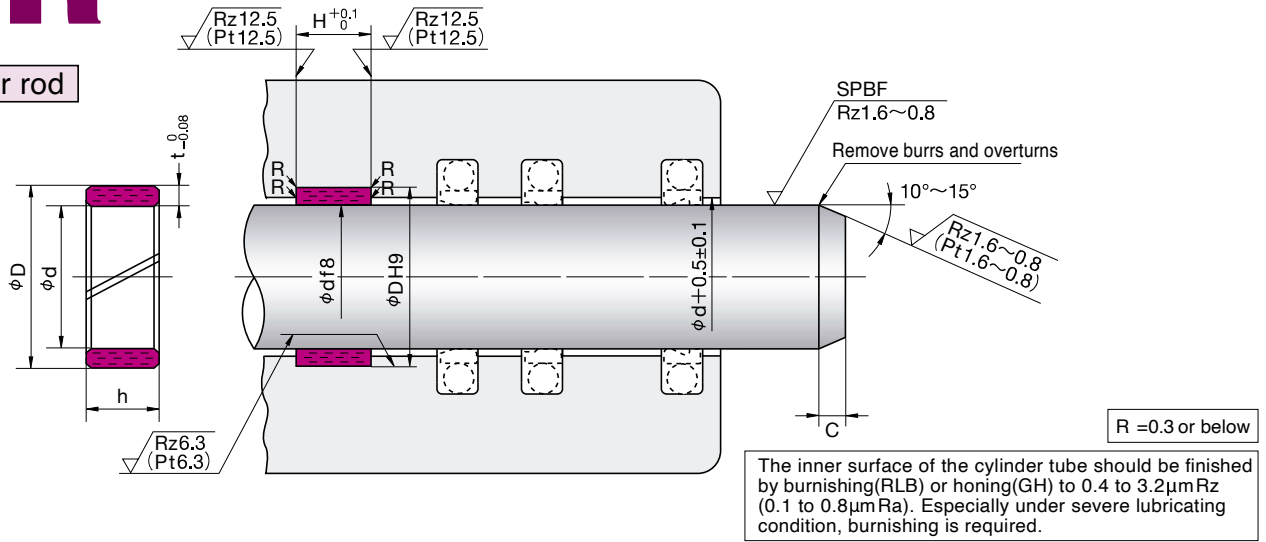

●The roughness is JIS B 0601 : 2001.
When regulation length cannot be kept, apply Pt.

Nominal Number	Nominal Size of Wear Ring, and Housing dimensions					NOK Part Number
	d	D	h	t	H	
WR 18 - 21.1 LC	18	21.1	3.9	1.55	4	GW1375V0
22.4 - 25.5 LC	22.4	25.5	3.9	1.55	4	GW1376V0
22.4 - 27.4 LD	22.4	27.4	5.5	2.5	5.6	GW1279V0
28 - 31.1 LC	28	31.1	3.9	1.55	4	GW1377V0
28 - 33 LD	28	33	5.5	2.5	5.6	GW1280V0
35 - 40 LD	35	40	5.5	2.5	5.6	GW1281V0
35.5 - 40.5 LD	35.5	40.5	5.5	2.5	5.6	GW1355V0
35.5 - 40.5 LA	35.5	40.5	9.5	2.5	9.7	GW1282V0
45 - 50 LD	45	50	5.5	2.5	5.6	GW1283V0
45 - 50 LA	45	50	9.5	2.5	9.7	GW1284V0
56 - 61 LD	56	61	5.5	2.5	5.6	GW1356V0
56 - 61 LA	56	61	9.5	2.5	9.7	GW1285V0
58 - 63 LD	58	63	5.5	2.5	5.6	GW1345V0
58 - 63 LA	58	63	9.5	2.5	9.7	GW1286V0
63 - 68 LD	63	68	5.5	2.5	5.6	GW1357V0
63 - 68 LA	63	68	9.5	2.5	9.7	GW1287V0
67 - 72 LD	67	72	5.5	2.5	5.6	GW1358V0
67 - 72 LA	67	72	9.5	2.5	9.7	GW1288V0
71 - 76 LD	71	76	5.5	2.5	5.6	GW1359V0
71 - 76 LA	71	76	9.5	2.5	9.7	GW1289V0
75 - 80 LD	75	80	5.5	2.5	5.6	GW1335V0
75 - 80 LA	75	80	9.5	2.5	9.7	GW1290V0
80 - 85 LA	80	85	9.5	2.5	9.7	GW1360V0
80 - 85 LB	80	85	14.8	2.5	15.0	GW1291V0
85 - 90 LA	85	90	9.5	2.5	9.7	GW1320V0
85 - 90 LB	85	90	14.8	2.5	15.0	GW1292V0
90 - 95 LA	90	95	9.5	2.5	9.7	GW1361V0
90 - 95 LB	90	95	14.8	2.5	15.0	GW1293V0
95 - 100 LD	95	100	5.5	2.5	5.6	GW1346V0

E DIMENSION WR

For piston

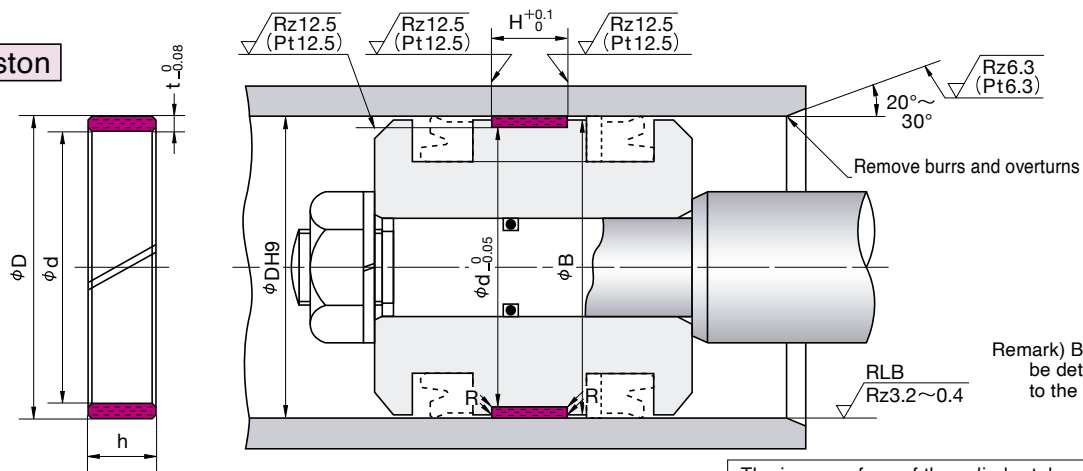

The inner surface of the cylinder tube should be finished by burnishing (RLB) or honing (GH) to 0.4 to 3.2 μm Rz (0.1 to 0.8 μm Ra). Especially under severe lubricating condition, burnishing is required.

● The roughness is JIS B 0601 : 2001.
When regulation length cannot be kept, apply Pt.

Nominal Number	Nominal Size of Wear Ring, and Housing dimensions					NOK Part Number
	d	D	h	t	H	
WR 95 - 100 LA	95	100	9.5	2.5	9.7	GW1294V0
100 - 105 LA	100	105	9.5	2.5	9.7	GW1362V0
100 - 105 LB	100	105	14.8	2.5	15.0	GW1295V0
112 - 117 LA	112	117	9.5	2.5	9.7	GW1363V0
112 - 117 LB	112	117	14.8	2.5	15.0	GW1296V0
120 - 125 LA	120	125	9.5	2.5	9.7	GW1347V0
120 - 125 LB	120	125	14.8	2.5	15.0	GW1297V0
125 - 130 LA	125	130	9.5	2.5	9.7	GW1364V0
125 - 130 LB	125	130	14.8	2.5	15.0	GW1298V0
135 - 140 LA	135	140	9.5	2.5	9.7	GW1348V0
135 - 140 LB	135	140	14.8	2.5	15.0	GW1299V0
140 - 145 LB	140	145	14.8	2.5	15.0	GW1365V0
140 - 145 LE	140	145	24.5	2.5	25.0	GW1300V0
145 - 150 LA	145	150	9.5	2.5	9.7	GW1349V0
145 - 150 LB	145	150	14.8	2.5	15.0	GW1301V0
155 - 160 LA	155	160	9.5	2.5	9.7	GW1350V0
155 - 160 LB	155	160	14.8	2.5	15.0	GW1302V0
160 - 165 LB	160	165	14.8	2.5	15.0	GW1366V0
160 - 165 LE	160	165	24.5	2.5	25.0	GW1303V0
175 - 180 LB	175	180	14.8	2.5	15.0	GW1351V0
175 - 180 LE	175	180	24.5	2.5	25.0	GW1304V0
180 - 185 LB	180	185	14.8	2.5	15.0	GW1367V0
180 - 185 LE	180	185	24.5	2.5	25.0	GW1305V0
195 - 200 LB	195	200	14.8	2.5	15.0	GW1352V0
195 - 200 LE	195	200	24.5	2.5	25.0	GW1306V0
219 - 224 LB	219	224	14.8	2.5	15.0	GW1353V0
219 - 224 LE	219	224	24.5	2.5	25.0	GW1307V0
245 - 250 LB	245	250	14.8	2.5	15.0	GW1354V0
245 - 250 LE	245	250	24.5	2.5	25.0	GW1308V0

E DIMENSION
WR

KZT TYPE

CONTAMI SEALS RAREFLON (PTFE)



E
DIMENSION
K
Z
T

- Please designate NOK Part number and type & size on your order.

(Example) · Type Dimensions

KZT

14

20

5

Type Sign

Nominal Size of Contami Seal
described in order of
inner diameter(d), outer diameter(D), and height(h)

· Part Number

GZ3000V0

- Please check the application range on pages 22 and 23 before selecting the type.

Material	NOK 05ZF
-----------------	----------

KZT TYPE CONTAMI SEALS

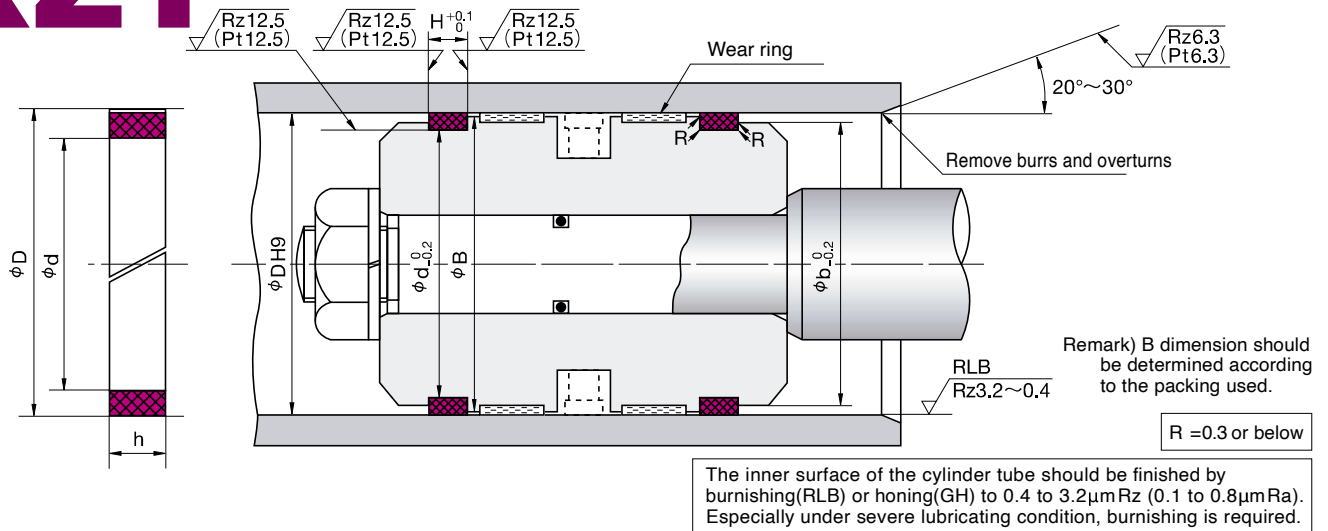

Nominal Number	Nominal Size of Contami Seal, and Housing dimensions					NOK Part Number
	d	D	h	H	ϕb	
KZT 20	14	20	5	5.2	18	GZ3000V0
25	19	25	5	5.2	23	GZ3001V0
30	24	30	5	5.2	28	GZ3002V0
31.5	25.5	31.5	5	5.2	29.5	GZ3003V0
32	26	32	5	5.2	30	GZ3004V0
35	29	35	5	5.2	33	GZ3005V0
35.5	29.5	35.5	5	5.2	33.5	GZ3006V0
40	34	40	5	5.2	38	GZ3007V0
45	39	45	5	5.2	43	GZ3008V0
50	44	50	5	5.2	48	GZ3009V0
53	47	53	5	5.2	51	GZ3010V0
55	49	55	5	5.2	53	GZ3011V0
56	50	56	5	5.2	54	GZ3012V0
60	54	60	5	5.2	58	GZ3013V0
63	55	63	6	6.2	61	GZ3014V0
65	57	65	6	6.2	63	GZ3015V0
70	62	70	6	6.2	68	GZ3016V0
71	63	71	6	6.2	69	GZ3017V0
75	67	75	6	6.2	73	GZ3018V0
80	72	80	6	6.2	78	GZ3019V0
85	77	85	6	6.2	83	GZ3020V0
90	82	90	6	6.2	88	GZ3021V0
95	87	95	6	6.2	93	GZ3022V0
100	92	100	6	6.2	98	GZ3023V0
105	97	105	6	6.2	103	GZ3024V0
110	102	110	6	6.2	108	GZ3025V0
112	104	112	6	6.2	110	GZ3026V0
115	107	115	6	6.2	113	GZ3027V0
120	112	120	6	6.2	118	GZ3028V0
125	117	125	6	6.2	123	GZ3029V0
130	122	130	6	6.2	128	GZ3030V0
135	127	135	6	6.2	133	GZ3031V0
140	132	140	6	6.2	138	GZ3032V0
150	142	150	6	6.2	148	GZ3033V0
160	152	160	6	6.2	158	GZ3034V0

E DIMENSION KZT

KZT TYPE CONTAMI SEALS

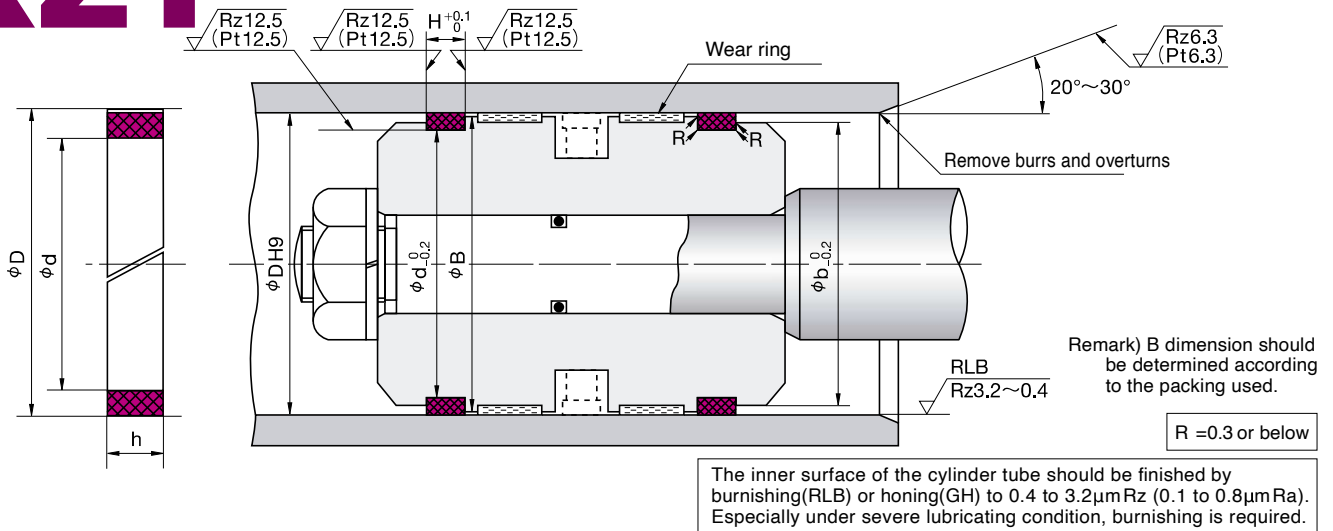

Nominal Number	Nominal Size of Contami Seal, and Housing dimensions					NOK Part Number
	d	D	h	H	ϕb	
KZT 170	162	170	8	8.2	168	GZ3035V0
180	172	180	8	8.2	178	GZ3036V0
190	182	190	8	8.2	188	GZ3037V0
200	192	200	8	8.2	198	GZ3038V0
210	202	210	8	8.2	208	GZ3039V0
220	212	220	8	8.2	218	GZ3040V0
224	216	224	8	8.2	222	GZ3041V0
230	222	230	8	8.2	228	GZ3042V0
240	232	240	8	8.2	238	GZ3043V0
250	242	250	8	8.2	248	GZ3044V0
260	252	260	8	8.2	258	GZ3045V0
270	262	270	8	8.2	268	GZ3046V0
280	272	280	8	8.2	278	GZ3047V0
290	282	290	8	8.2	288	GZ3048V0
300	292	300	8	8.2	298	GZ3049V0
310	302	310	8	8.2	308	GZ3050V0
320	312	320	8	8.2	318	GZ3051V0
340	332	340	8	8.2	338	GZ3052V0
350	342	350	8	8.2	348	GZ3053V0
360	352	360	8	8.2	358	GZ3054V0

E DIMENSION KZT

F

HANDLING OF NOK PACKINGS

REMARKS FOR DESIGNING CYLINDERS	228
INSTALLATION OF PACKINGS	229 ~ 235
INSTALLATION OF DUST SEALS	235
REMARKS ON ASSEMBLING CYLINDERS	236

F. HANDLING OF NOK PACKINGS

1. REMARKS FOR DESIGNING CYLINDERS

■ CYLINDER TUBE MATERIAL

The materials described in **Table F-1** are generally used for cylinders.

Aluminum alloy, bronze, brass, Monel metal and soft stainless steel may be used for low-pressure applications depending on circumstances. They are not recommended for use over long periods of time due to poor wear resistance. The following table shows the materials specified by JIS.

〈Table F-1〉

Kinds	Material
Material for tubes	JIS G 3473 (Carbon steel pipe for cylinder tubes) JIS G 3445 (Carbon steel pipe for mechanical structures)
Material for rods	JIS G 4051 (Carbon steel material for mechanical structures)

■ INSIDE CYLINDER FACE FINISH AND ROUGHNESS

Generally, a honed finish and a burnishing finish are recommended for the inside face of the cylinder tube. Avoid finishing the face with a pattern aligned in a lateral direction.

Specially, under severe lubricating application, burnishing is required.

NOK uses 0.4 - 3.2 μ m Rz (0.1 - 0.8 μ m Ra) as the inside face finish on a cylinder tube as standard.

■ ROD SURFACE AND ROUGHNESS

0.8 ~ 1.6 μ m Rz (0.2 ~ 0.4 μ m Ra) with buff finish, after heat treatment, plating the steel with hard chrome is recommended for rod surface. Never use decorative nickel plating or chrome.

Cylinder rod used for construction machinery is likely to be scored by sands or pebbles, so minimum hardness should be 60 (HRC)

■ ROUGHNESS OF INSIDE FACE OF FITTING GROOVE

Since a rough inside face of the fitting groove affects the sealing of a packing, use a finish value mentioned on the Dimensional Table. In fitting the packing, it is easily scratched, so finish the top end of the groove completely removing any burrs, sharp edges and scars.

■ BEARING CLEARANCE AND EXTRUSION GAP

Since sealing performance is greatly affected by extrusion gap and bearing clearance, design should be set as small as possible. (See Dimensional Table for bearing clearance and extrusion gap)

Never use a packing in such a way that the packing replaces a bearing.

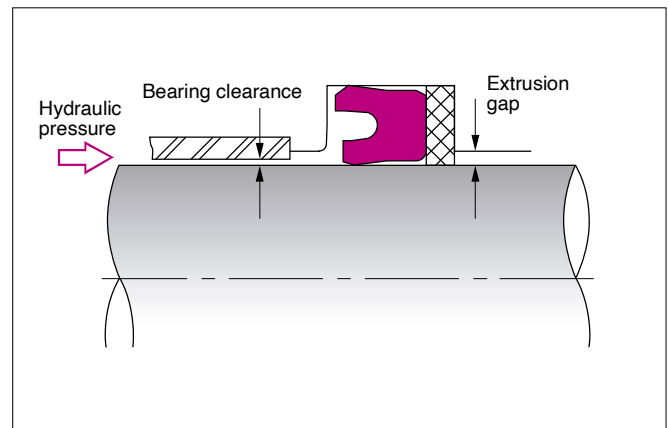

〈Fig. F-1〉

■ DESIGN OF PACKING INSERTION PORT

There is an interference on the I.D. and O.D. of the packing to achieve sealing performance. When installing a packing in a cylinder, the lip of the packing, its most important part, is easily damaged, if the size and construction of the chamfered edge of the insertion port are poor*.

Especially, apply stepped design to any threaded part as shown in **Fig. F-2**. (See Dimensional Table for size).

* Key grooves, splines, etc.

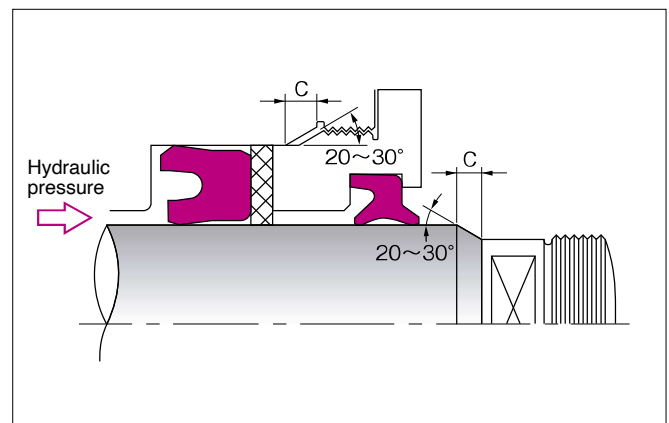

〈Fig. F-2〉

2. INSTALLATION OF PACKINGS

When installing packings, fitting construction differs from one to another depending on the type of packing. The installation method will also vary. It is possible to install a packing with a small profile design and a combination seal

in an integral groove, but in other cases, it is necessary to use a split groove construction, the detail of which is mentioned in each page shown in **Table F-2**. See Dimensional Table for construction of the fitting groove.

〈Table F-2〉 List of installation methods

Kind	Construction of groove	Iron rubber U packing	Nitrile rubber packing	Combined seal	Other packing
Packings for piston seals (Example of installation 2-1)	Integral groove ^(Note)	Installation method A (Page F-3)	Installation method B (Page F-3)	Installation method C (Page F-4~6)	C packing : Installation example 2-3 (Page F-8)
	Split groove	A packing can be installed easily. Installation method D (Page F-6)			V packing : Installation example 2-4 (Page F-8)
Packings for rod seals (Example of installation 2-2)	Integral groove ^(Note)	Installation method E (Page F-6)	Installation method F (Page F-7)	Installation method G (Page F-7)	Buffer ring : Installation example 2-5 (Page F-9)
	Split groove	A packing can be installed easily. Installation method H (Page F-7)			

(Example of structure of fitting groove for piston packing)

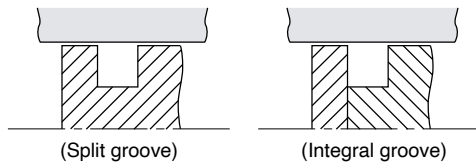

(Split groove)

(Integral groove)

(Example of structure of fitting groove for rod packing)

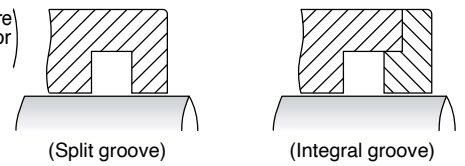

(Split groove)

(Integral groove)

- Note 1) Some of the parts with a small diameter cannot be installed in an integral groove. Kindly check with Dimensional Table.
 Note 2) Install the U packing in such a direction that its lip comes to oil pressure side as it is shown on Fig. F-1 and Fig. F-2 at page F-2.
 Note 3) If difficult to assemble, soak the rubber in oil (the oil you normally use) at around 60°C for around ten minutes and soak the Rareflon in either hot water or oil at around 60°C for around ten minutes. This will make it easier to assemble.

INSTALLATION EXAMPLE 2-1 PACKINGS FOR PISTON SEALS

■ METHOD A: INSTALLATION OF IRON RUBBER U PACKING INTO INTEGRAL GROOVE (MAIN APPLICABLE TYPES: OSI, OUIS, USI)

Some of the parts with a small diameter cannot be installed in an integral groove. Refer to the Dimension Table.

INSTALLATION METHOD

- ① Prepare a pivot with an arm which corresponds to the diameter of the piston rod.
- ② First of all, be sure to apply hydraulic oil to ensure easy installation of the packing on the piston rod.

- ③ Fit part of a packing into the installation groove as shown in **Fig. F-3**.
- ④ Hold the packing with the thumb, then install the pivot into the hole as shown in **Fig. F-4**.
- ⑤ Rotate the packing once pressing down the arm handle as shown in **Fig. F-5**.



〈Fig. F-3〉



〈Fig. F-4〉



〈Fig. F-5〉

■ METHOD B: INSTALLATION OF A NITRILE RUBBER U PACKING IN AN INTEGRAL GROOVE (MAIN APPLICABLE TYPES: OUHR, USH)

Some of the parts with a small diameter cannot be installed in an integral groove. Refer to the Dimension Table.

INSTALLATION METHOD

The packing can be easily installed by inserting it in one side of the groove and stretching the other side of the packing to fit in place. (**Fig. F-6**)



〈Fig. F-6〉

METHOD C: INSTALLATION OF COMBINATION SEALS IN AN INTEGRAL GROOVE (MAIN APPLICABLE TYPES: SPG, SPGO, SPGW)

In case of combined seals, correction of Rareflon ring is necessary after installing the back ring and the Rareflon ring into the integral groove. Installation method and correction method are explained below.

INSTALLATION METHOD



〈Fig. F-7〉



〈Fig. F-8〉



〈Fig. F-9〉

- ① Prepare a slide tool and push-in tools shown in the figure. Flush clean the inside face of the cylinder and the fitting groove before installation.
- ② Install the back ring into the fitting groove. Never over stretch or over bend the back ring when installing it.
- ③ Fit the slide tool in the piston. Then quickly push in the Rareflon ring using push-in tool.

[INSTALLATION TOOLS FOR RAREFLON RING]

Shapes of tools used for installation and correction of the Rareflon ring are as follows. Sizes for each part of the push-in and slide tools are according to the sizes of the Rareflon ring (D, T, h) and the piston (ϕA , B, H, chamfer).

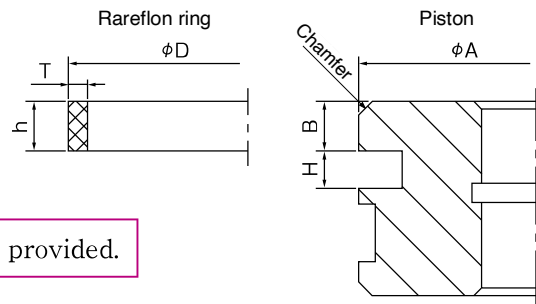

NOK could supply Gigs if ϕA , B, H and chamfer dimension are provided.

〈Table F-3〉

SPG PACKING *		SPGO PACKING		SPGW PACKING	
ϕD	T	ϕD	T	ϕD	T
30 ~ 35.5	1.6	20 ~ 25	1.0	50 ~ 60	2.3
36 ~ 60	1.9	30 ~ 60	1.25	61 ~ 120	2.5
61 ~ 100	2.4	61 ~ 160	2.0	121 ~ 200	3.5
101 ~ 160	2.9	161 ~ 200	2.5	—	—
161 ~ 250	3.5	—	—	—	—

* For installation tools with packing greater than $\phi 200$, consult NOK separately.

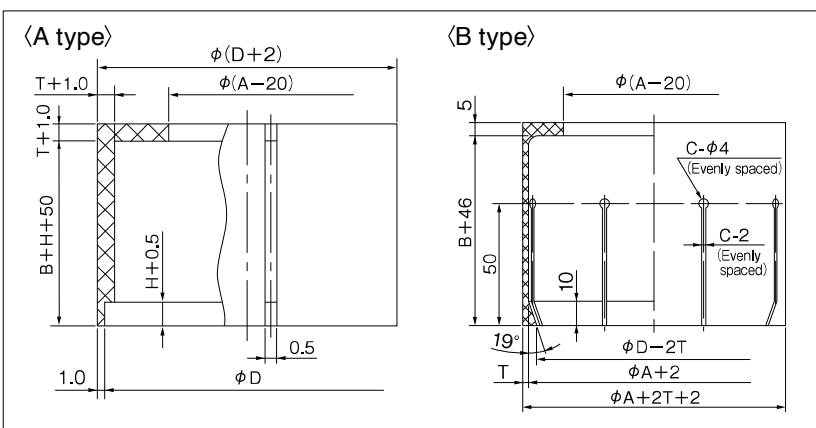

〈Fig. F-10〉 Push-in tool (Made of resin)

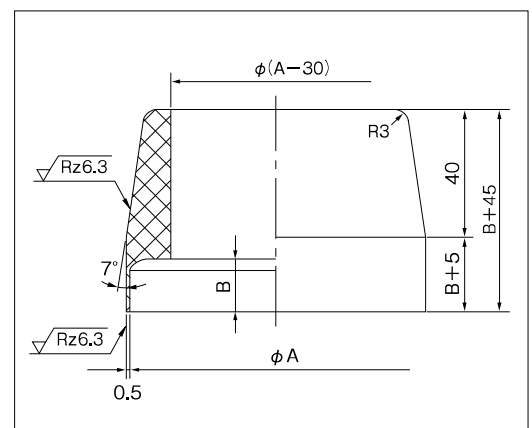

〈Fig. F-11〉 Slide tool (Made of metallic)

*A type is the standard article.

*B type is easier to assemble.

*Guide to number of slits on B type is provided below.

ϕD	Slits (Evenly spaced)
Up to 50	4
Over 50 to 100	6
Over 100 to 200	8

● CORRECTION METHOD OF RAREFLON RING

CORRECTION METHOD 1.

For combination seals, correct the Rareflon ring after installing the back ring and the Rareflon ring in the fitting groove. For SPGW packings, carry out the correction. Where correction

method 1 is insufficient, use correction method 2. On the other hand, carry out correction according to the correction method 2 for packings whose nominal numbers exceed 400.



〈Fig. F-12〉



〈Fig. F-13〉



〈Fig. F-14〉

- ① Prepare a twist bar and adapter as shown in the figure. Set the twist bar and adapter as shown, then set the Rareflon ring in the center of the band.
- ② Hold for 10 seconds or more.
- ③ Installation is completed by the above steps. The internal and external circumference faces of the Rareflon ring affect sealing performance, so be careful not to scratch the ring.

[JIG FOR CORRECTION METHOD 1]

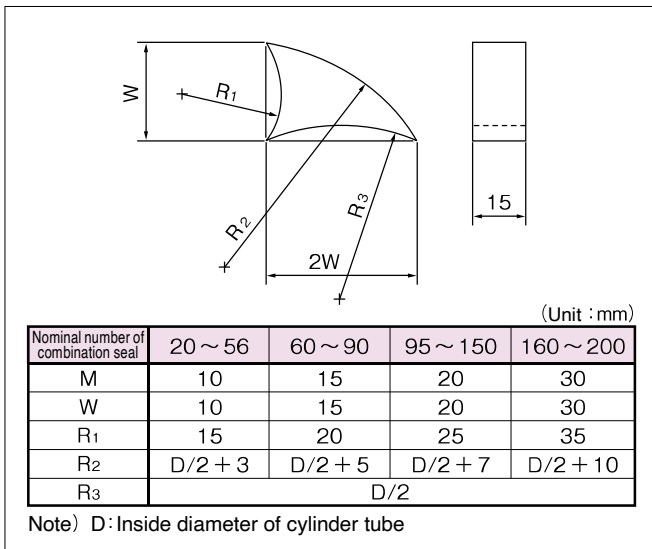

〈Fig. F-15〉 Adapter (Rareflon)

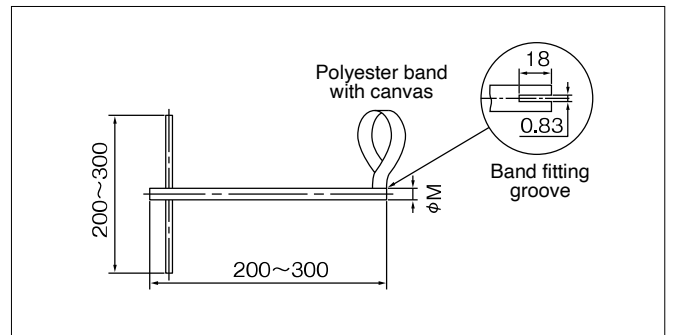

〈Fig. F-16〉 Twist bar (Metal and Polyester band with canvas)

Push-in jig, slide jig, adapter, twist bar, and correction tube are manufactured by NOK. Order with us.

CORRECTION METHOD 2.

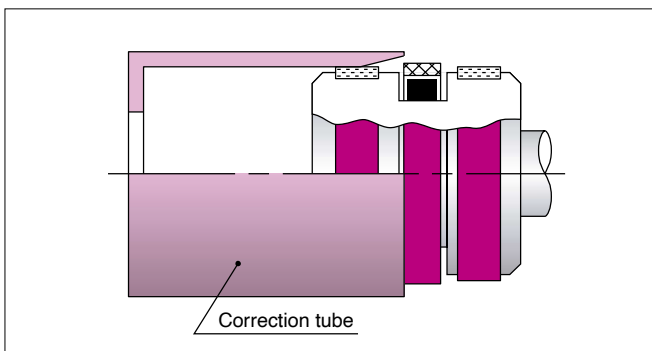

〈Fig. F-17〉

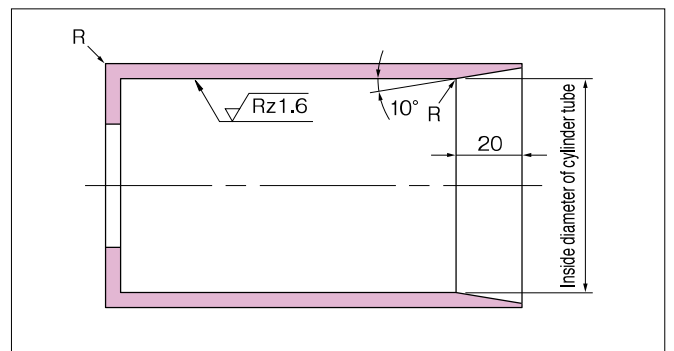

〈Fig. F-18〉 Correction tube (metal)

- ① Prepare a correction tube shown in Fig. F-17
- ② Insert a piston after applying hydraulic oil (oil actually used) and pull the piston mount after having left it there for about 10 seconds.

● SPGC TYPE PACKINGS

For SPGC packings having inside diameter below $\phi 50$, use divided grooves generally. When the divided groove is not available or for inside diameter of the cylinder tube $\phi 50$ or more, first install O-ring in the fitting groove and then install the Rareflon ring with a tool shown in the figure.

D	F
~ Below 56	1.3
58 ~ 160	1.5
165 ~ 400	2.0

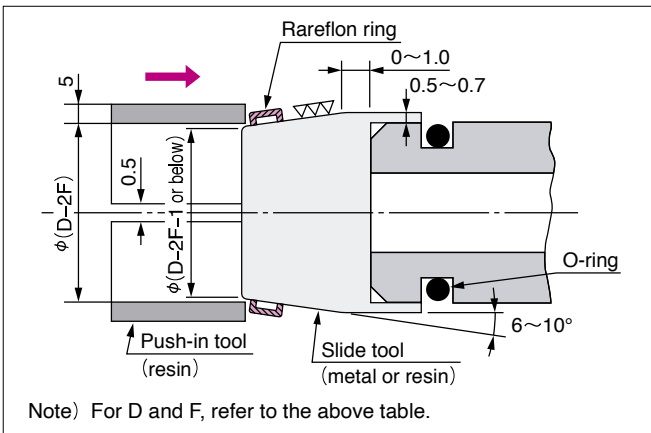

(Fig. F-19)

■ METHOD D: INSTALLATION INTO DIVIDED GROOVE (Applicable to packings for piston seals in general)

No special tool is required for installation into a divided groove. Packings can be easily installed by hand.

Be careful not to scratch the packing by the fitting groove or angle.

EXAMPLE OF INSTALLING 2-2 PACKINGS FOR ROD SEALS

■ METHOD E: INSTALLATION OF IRON RUBBER U PACKING INTO INTEGRAL GROOVE (MAIN APPLICABLE TYPES: ISI, IUIS, USI)

Some of the parts with a small diameter cannot be installed in an integral groove. Refer to the Dimension Table.

INSTALLATION METHOD

- ① When using a backup ring together, first install the buffer ring into the fitting groove as shown in Fig. F-20.
- ② Prepare special plugs and push-in rods suitable for respective diameters. Use soft resin for material and it is necessary to make the upper parts of the tools slide into the packings smoothly. Fit the packing by hand as shown in Fig. F-21.
- ③ When the uppermost part of the packing is pushed in with a special push-in rod, the packing can be installed easily in the fitting groove, making a "Click" noise.

Processes shown in Fig. F-21 and Fig. F-22 should be completed as quickly as possible in order to prevent a permanent deformation of the packing. Be careful not to stop or interrupt the operation in the middle.

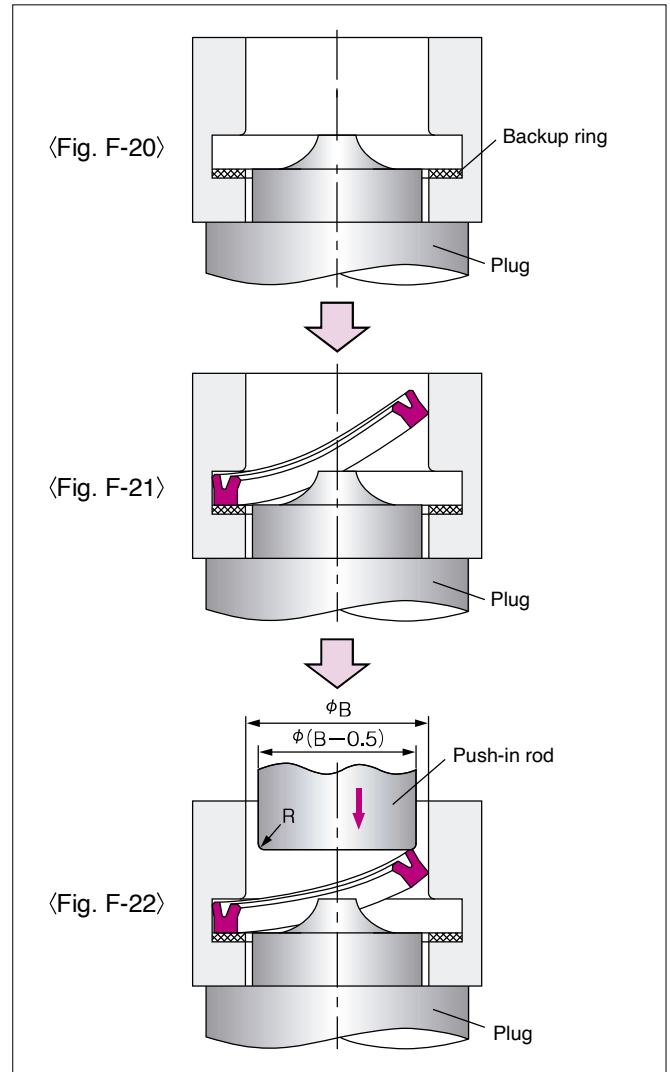

■ METHOD F: INSTALLATION OF NITRILE RUBBER U PACKING INTO INTEGRAL GROOVE (MAIN APPLICABLE TYPES: IUH, USH)

Some of the packings with a small diameter cannot be installed into an integral groove. Kindly check it with the Dimensional Table.

INSTALLATION METHOD

- ① Deform the packing into a heart-shape with the fingers as shown in Fig. F-23. At this moment, be careful not to "scratch" the packing with "nails".
Install the packing as quickly as possible in order to prevent permanent deformation.
- ② The packing inserted in the fitting groove may get a little warped, so correct it with a finger or spatula.



〈Fig. F-23〉

METHOD G: INSTALLATION OF COMBINATION SEAL INTO INTEGRAL FITTING GROOVE (MAIN APPLICABLE TYPES: SPN, SPNO, SPNS)

Combination seals cannot be installed into an integral groove on a rod having a rod diameter below $\phi 50$ (SPNS, rod diameter under $\phi 30$).

In the case where the rod diameter exceeds $\phi 50$ (SPNS, the rod diameter exceeds $\phi 30$), take the following steps to install the combination seal.

CORRECTION METHOD 2.

- ① Insert the back ring into the fitting groove.
- ② Prepare special plugs and push-in rods suitable for respective diameters.
- ③ Install the Rareflon ring into one side of the fitting groove as shown in the Fig. F-24 and push it in with the push-in rod.

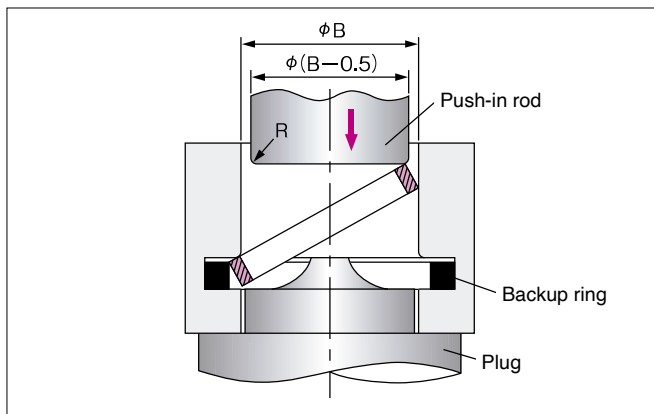

〈Fig. F-24〉

Since SPNS has the directional property, pay attention to the direction in which the rareflon ring is installed. (Fig. F-25)

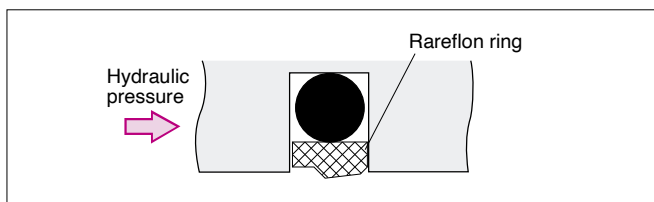

〈Fig. F-25〉

CORRECTION METHOD 2.

When installing the rareflon ring after squeezing it, install it in the following manner. However, minimize any deformations because it affects the sealing characteristics.

- ① Install the back ring in the mounting groove.

- ① Squeeze the rareflon ring into a heart shape as shown in Fig. F-26, using fingers or a bar. At this time, be careful not to bend the rareflon ring sharply.

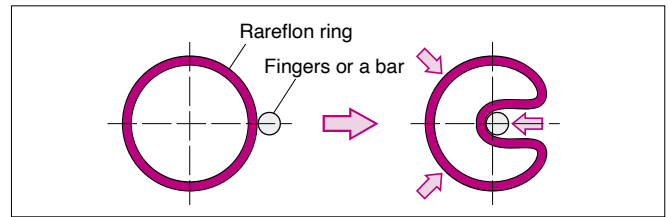

〈Fig. F-26〉

- ③ Insert the rareflon ring into the groove and then push it from the inside in the outer circumference direction so that it returns to the original shape.

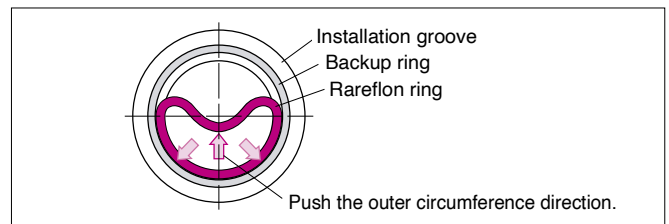

〈Fig. F-27〉

- ④ Insert the jig (or the rod) several times to correct the deformation of the inner circumference of the rareflon ring.

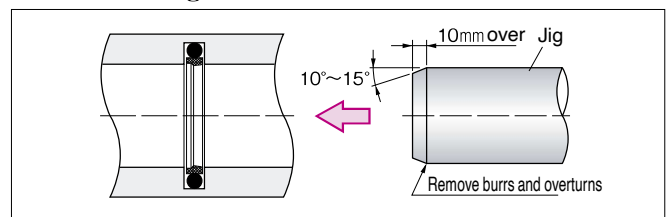

〈Fig. F-28〉

METHOD H: INSTALLATION IN SPLIT GROOVE (Applicable to packings for rod seals in general)

U PACKINGS

No special tools are required to install U packings from the heel. All packings are easily inserted. When installing U packings from the lip, be particularly careful not to scratch them with the top end of the fitting groove. U packing can be installed by another method using a bushing for assembly and a push-in rod as shown in the Fig. F-29.

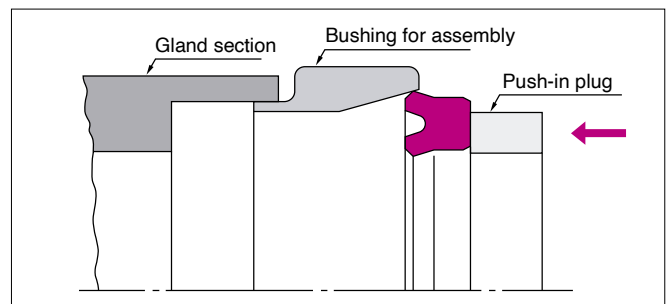

〈Fig. F-29〉

INSTALLATION OF COMBINATION SEAL

For installation of SPNC packing, pre-assemble the back ring (O-ring) and Rareflon ring before installation.

The back ring and rareflon ring can be installed separately with SPN, SPNO and SPNS types.

EXAMPLE OF INSTALLING 2-3 C-SHAPE PACKINGS

(Applicable types: CPI, CPH)

Design fitting groove of C-shape packing so that the packing is tightened properly as shown in the Figs. F-30-1 (a), (b) and (c).

Deformation as shown in Fig. F-30-2 occurs when the packing is over tightened.

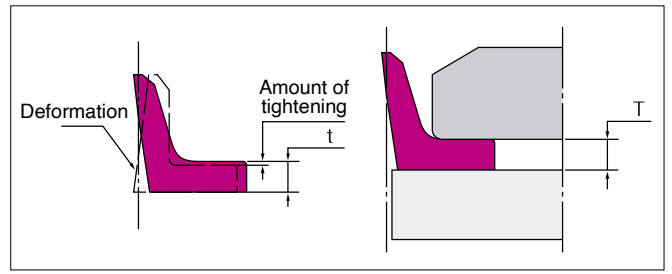

(Fig. F-30-2)

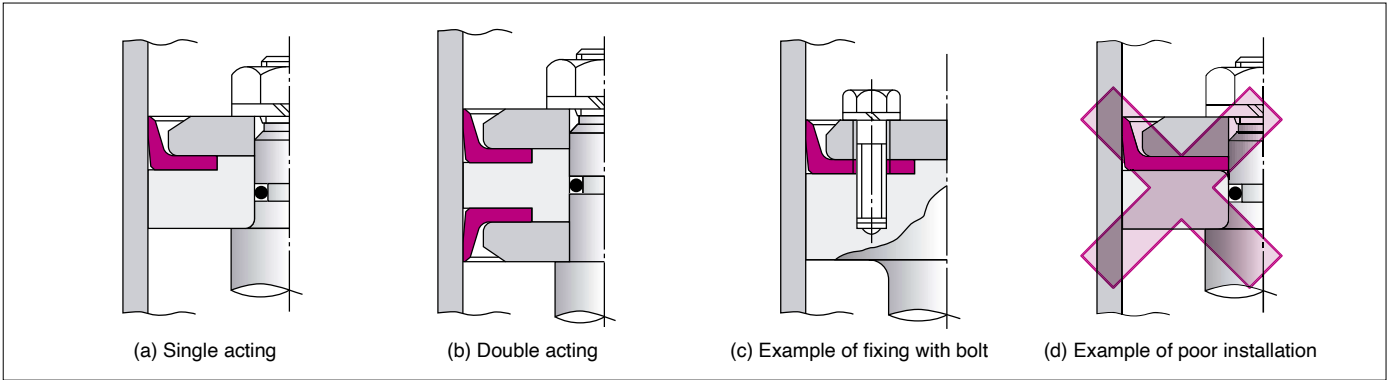

(Fig. F-30-1)

EXAMPLE OF INSTALLING 2-4 V-SHAPE PACKINGS

(Main applicable types: V99F, V96H)

It is not necessary to use Gigs when installing a V-shape packing to the ground.

HANDLING OF NOK PACKINGS

INSTALLATION METHOD

- ① Clean inside the gland well and apply grease or hydraulic oil lightly.
- ② Apply grease or hydraulic oil on the packing face, securely insert packings one by one to avoid twisting or warping.
- ③ When glands of V-shape packings for rod seals are as shown on the Fig. F-31, be careful not to "scratch" the top end of the lip by threads or chamfered part. Make sure there is no "turnover" or "burrs" on the chamfered part and then insert the packing.

- ④ Tighten the "packing holder" just enough to fix the packing, by adjusting the shim, etc. Over tightening will increase the friction and wear of the packing and shorten its life. See page 159 for the initial tightening amount.
- ⑤ The fabric reinforced V-shape packing may be compressed by service pressure while in use and shift in the gland to cause leakage. Apply additional tightening of the packing holder and then make adjustment. The amount of tightening must be within the limit given in Fig. F-32. When only using rubber V-shape packing, do not apply additional packing.

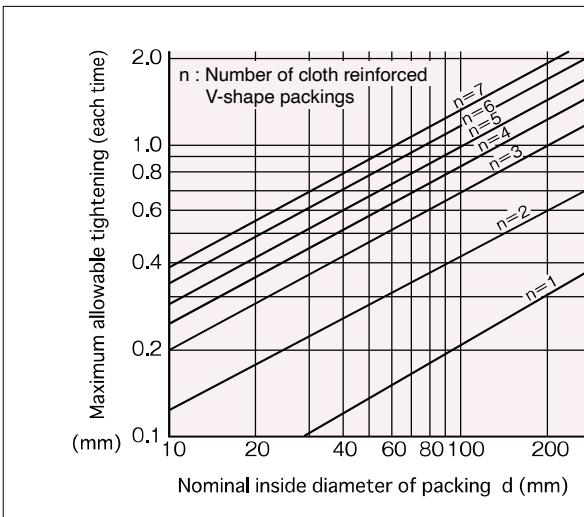

● When fabric reinforced rubber V-shape packing is used in combination with rubber V-shape packing, do not count the number of rubber V-shape packings.

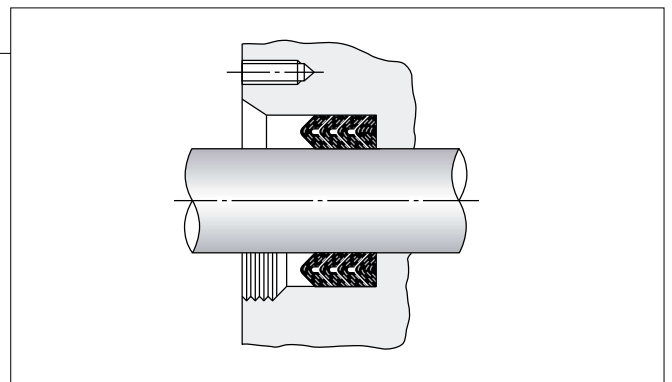

(Fig. F-31)

(Fig. F-32) Max. allowable tightening

EXAMPLE OF INSTALLING 2-5 BUFFER RINGS

(Applicable types: HBTS, HBY)

Buffer rings can be installed into integral grooves.

● HBTS

As same steps for SPN packing installation, install HBTS packings following to the installation method in **page F-7**.

Pay attention to the direction of the Rareflon ring as shown in **Fig. F-33**.

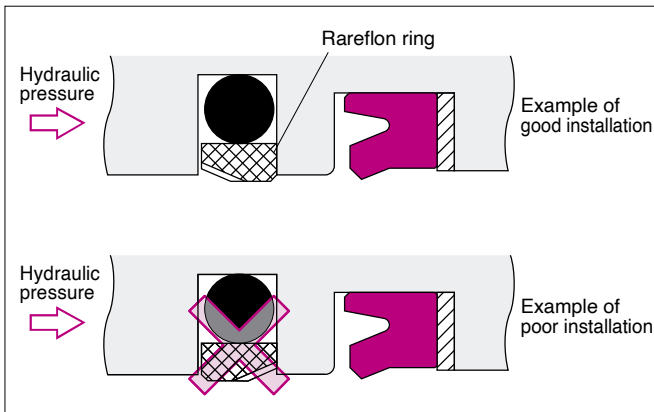

(Fig. F-33)

● HBY

Install the packing as deforming into a heart-shape with fingers. Then assembled the back ring.

Pay attention to the direction of the Rareflon backup ring as shown in **Fig. F-34**.

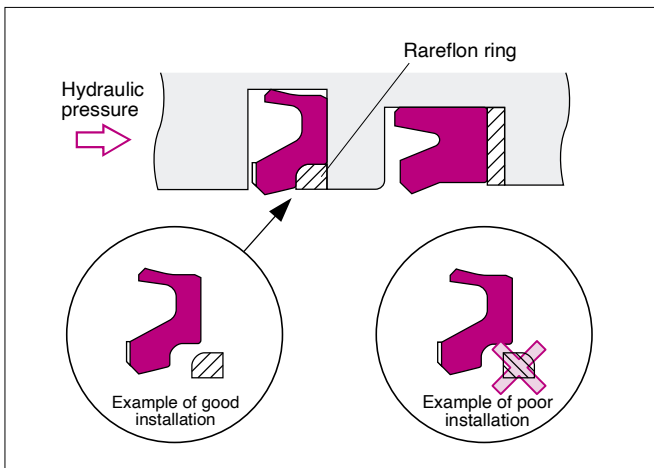

(Fig. F-34)

3. INSTALLATION OF DUST SEALS

(Applicable to dust seals in general)

● DSI, LBI, LBH, LBHK

As a dust seal is a single part, squeeze it into a heart shape and install it carefully being careful not to “scratch” it with “fingers” .

When using LBHK outdoor, apply grease sufficiently to the inside of the installation groove, to prevent rust.

● DKI, DWI, DWIR, DKBI, DKBI3, DKBZ, DKH, DKB

Dust seals are pressed in a fitting groove. Prepare press-in tools as shown in the following figure.

INSTALLATION METHOD

- ① Set the dust seal horizontally to the housing hole.
- ② With a press, carefully push in the dust seal using installation tools so as not to deform the dust seal lip nor to incline the dust seal.

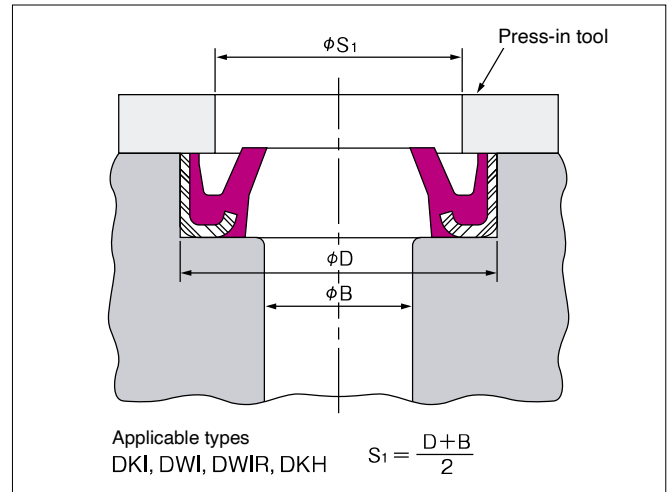

(Fig. F-35)

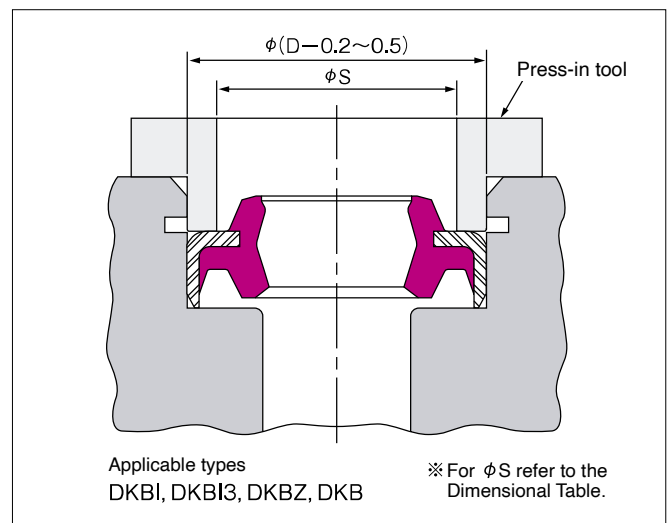

(Fig. F-36)

● DSPB

Install LBHK in the same manner as the SPN packing after referring to the installation method described on **page F-7**.

Be careful of the direction in which the rareflon ring is installed, as shown in **Fig. F-37**.

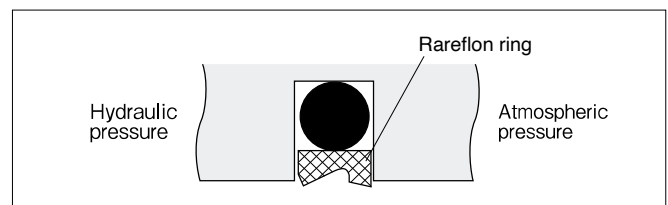

(Fig. F-37)

4. REMARKS ON ASSEMBLING CYLINDERS

Sealing performance of a packing is greatly influenced by the method of assembling a cylinder. Please check the following points.

1. Eliminate foreign materials from the internal surface of the cylinder tube and interior of pipes.
2. When using packings from storage, do not use those that have foreign material such as dust, sand, etc., as this will cause leakage.
3. Apply hydraulic oil (the same oil used in the machine) to the packing, gland, rod surface and internal face of the cylinder, then assemble the cylinder.
4. Put a protective cover over the lip of the packing so that it does not directly contact the "thread" and steps. (Fig.F-38)
5. When it is necessary to let the lip of the packing pass through a hydraulic pressure port as in Fig. F-39, lightly push the lip with a spatula (resin). This prevents damage to the lip of the packing by the chamfer of the port. Chamfer as shown in Fig. F-40 when drilling a hole directly on the cylinder for a hydraulic port.

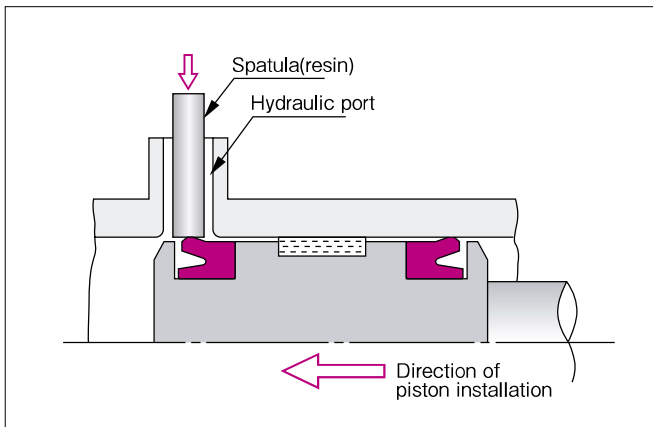
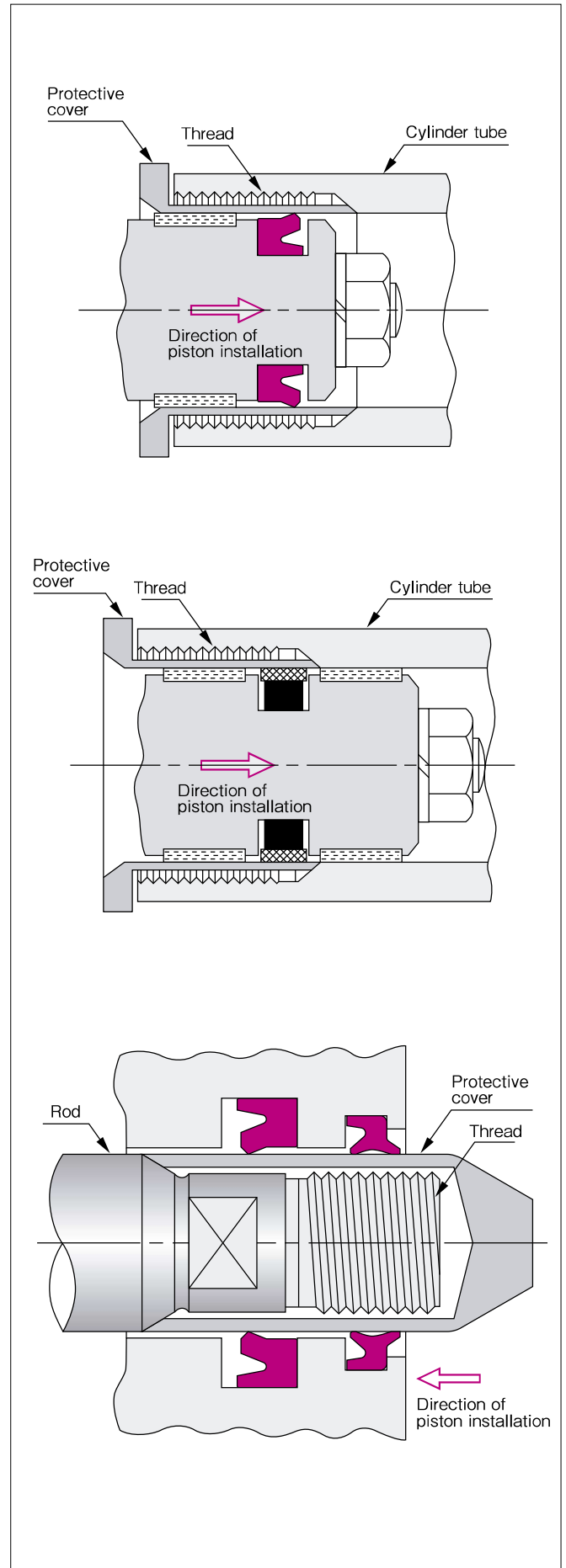

<Fig. F-39>

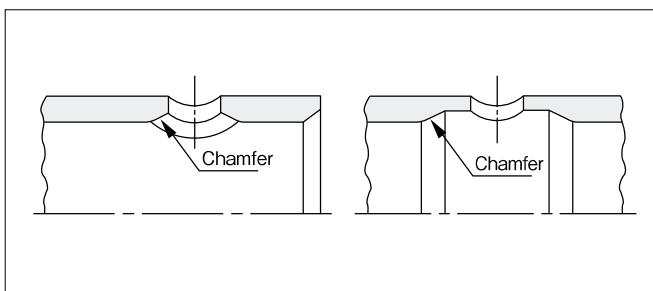

<Fig. F-40>

G

WHEN LEAKAGE OCCURS

Cause of Leakage — 238 ~ 239

Failure Mode and Countermeasures — 240 ~ 249

G. WHEN LEAKAGE OCCURRED

CAUSE OF LEAKAGE

In this chapter, we will introduce the main causes of oil leakage from the sealing and examples of countermeasures.

When oil leakage is observed, first check the source of the leakage.

Sometimes a deposit of grease is mistaken for oil leakage. If leakage from the seal is confirmed, see if there are any abnormalities with the seal contact area.

The following examples of leakage are classified into two groups: Check cases where there are no abnormalities with the seal contact area.

And cases where abnormalities are observed with the seal contact area.

<Table G-1>

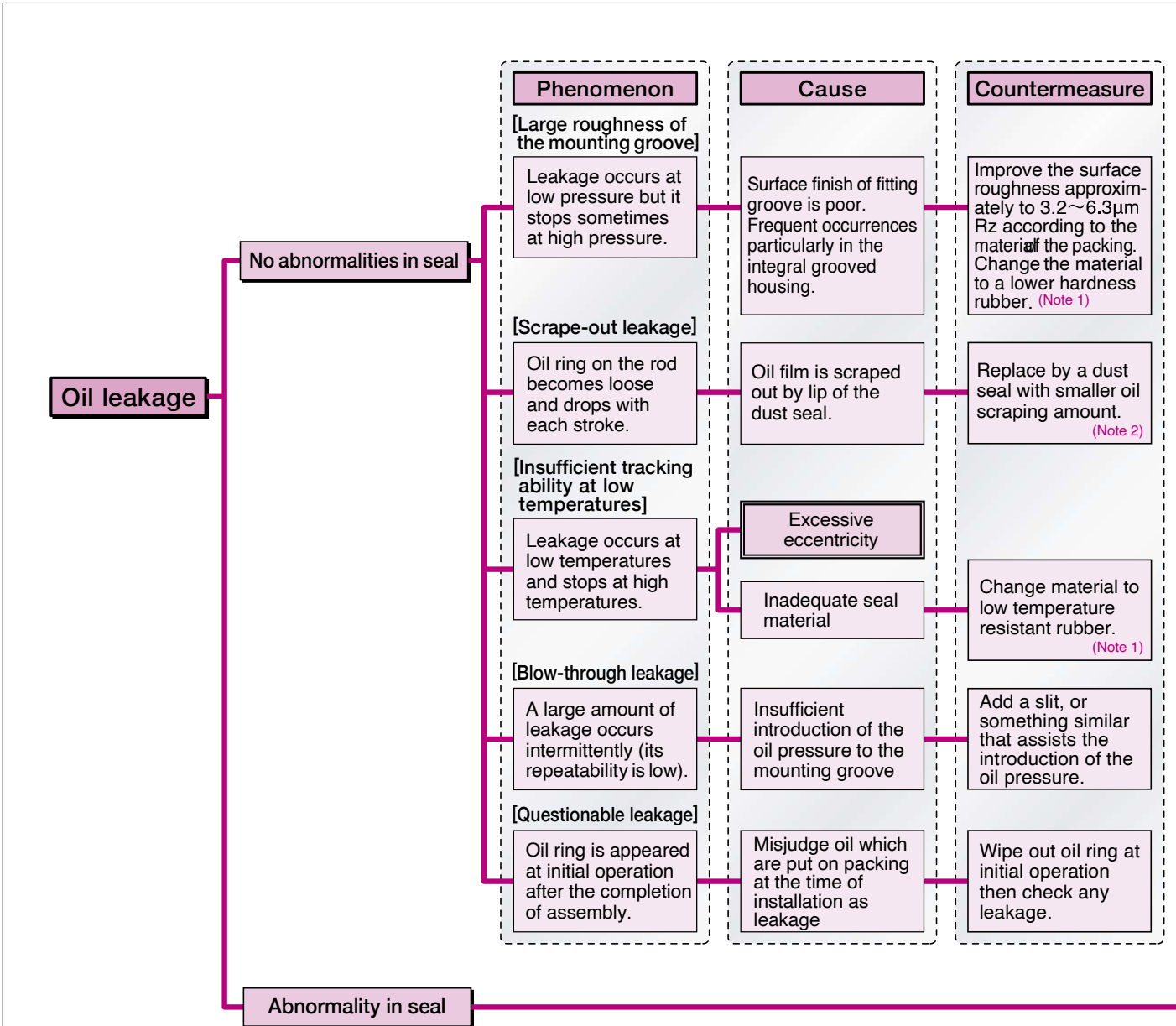

Note 1) When changing the seal material, consult NOK because other conditions must be considered.

Note 2) Dust resistance and seal performance are conflicting properties, so it is important to balance them.



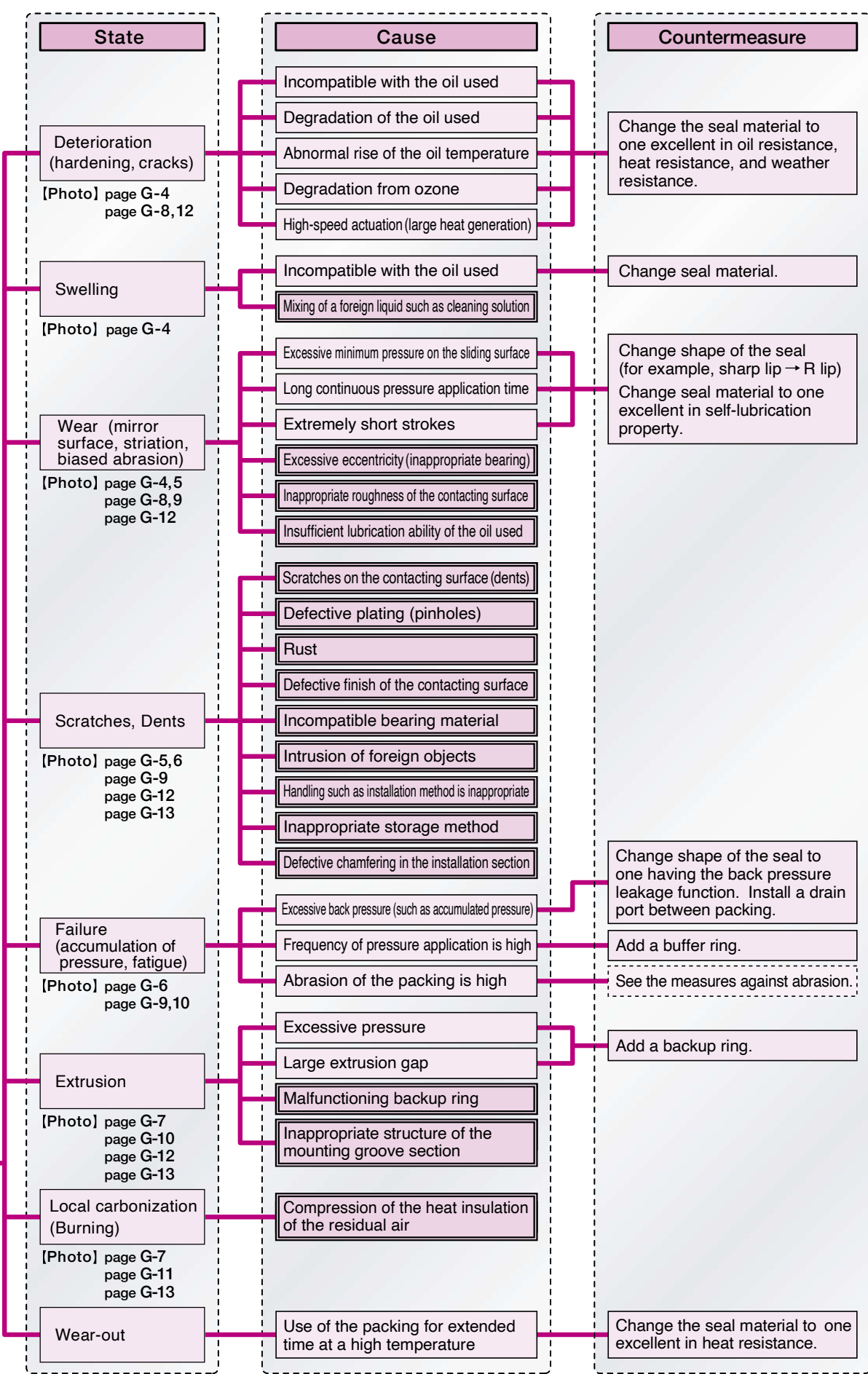





Note 3) , is difficult to take countermeasures for seal abnormalities by improving the seal, so improve the usage conditions.

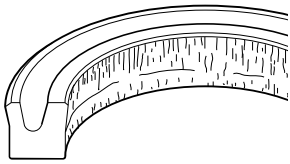

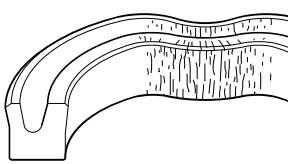
WHEN LEAKAGE OCCURS

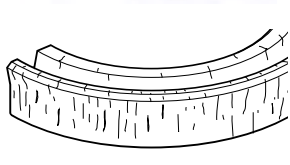
FAILURE MODE AND COUNTERMEASURES

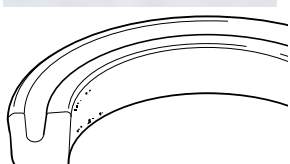
NITRILE RUBBER PACKINGS

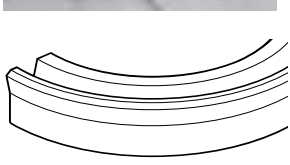
Appearance		Cause	Countermeasure
Fact	Condition		
Deterioration	  Hardening of the whole sliding face. Glazing and cracks on the surface. Push with a finger and cracks appear.	<ul style="list-style-type: none"> ● Heat generation by high speed or excessive internal pressure 	<ul style="list-style-type: none"> ● In case of a piston, change to SPG (SPGW). ● In case of rod, use buffer ring together.
	  The whole packing hardens and lip deflects greatly and when bent with a finger, cracks appear.	<ul style="list-style-type: none"> ● High oil temperature 	<ul style="list-style-type: none"> ● Lower oil temperature or change to heat resistant material (fluorine rubber)
	  Fine cracks all over the packing surface.	<ul style="list-style-type: none"> ● Influence of oil <ul style="list-style-type: none"> ● Incompatibility of oil and rubber material ● Deterioration of oil 	<ul style="list-style-type: none"> ● Change to oil resistant rubber material ● Renew oil.
Swelling	  Whole packing is softened	<ul style="list-style-type: none"> ● Ozone cracks from exposing packing to air too long. 	<ul style="list-style-type: none"> ● Do not open package unnecessarily but store it in a cold place as sealed.
		<ul style="list-style-type: none"> ● Ozone cracks from leaving it installed with piston. 	<ul style="list-style-type: none"> ● Do not leave packing installed with piston but assemble into cylinder as quickly as possible.
Wear	  The sliding surface shows wear with gloss.	<ul style="list-style-type: none"> ● Oil and rubber material are incompatible. 	<ul style="list-style-type: none"> ● Change to oil resistant material.
		<ul style="list-style-type: none"> ● Influence of cleaning liquid 	<ul style="list-style-type: none"> ● Change cleaning liquid. ● Remove cleaning liquid.
		<ul style="list-style-type: none"> ● Sliding stroke was extremely short and caused insufficient lubrication. 	<ul style="list-style-type: none"> ● In case of a piston, change to SPG (SPGW). ● In case of rod, use buffer ring together.
		<ul style="list-style-type: none"> ● Roughness of sliding surface is inappropriate (too good) 	<ul style="list-style-type: none"> ● Change to recommended roughness.

WHEN LEAKAGE OCCURS

FAILURE MODE AND COUNTERMEASURES



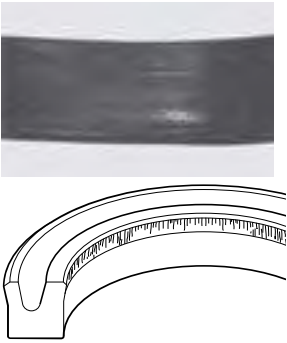
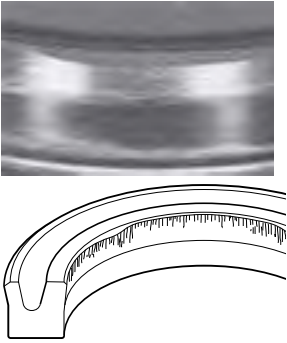
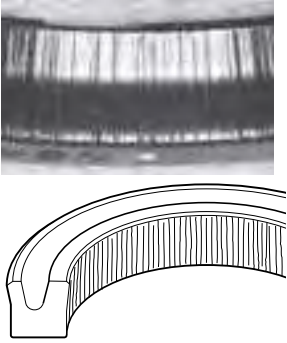
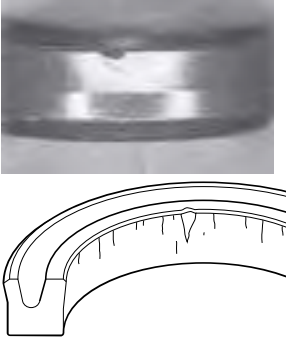
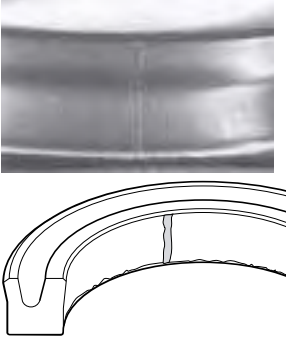



NITRILE RUBBER PACKINGS

Appearance		Cause	Countermeasure
Fact	Condition		
Wear	 <p>The lip contact width continuously differs on the circumference, and the position of maximum and minimum width are roughly symmetrical.</p>	<ul style="list-style-type: none"> ● Eccentricity of rod and cylinder head and cylinder and piston head. 	<ul style="list-style-type: none"> ● Make eccentricity of installation within the tolerance of packings.
	 <p>Abnormal wear observed at one portion of the circumference of the sliding lip (matching the direction of lateral load).</p>	<ul style="list-style-type: none"> ● Abnormal wear of wear ring (piston) and bearing by excessive lateral load. 	<ul style="list-style-type: none"> ● Change wear ring and bearing material to those which can withstand a heavy load.
Grooved Wear	 <p>The sliding surface has worn in a striation pattern.</p>	<ul style="list-style-type: none"> ● The seal slides at an extremely short stroke, and the shape of the lubricating oil film is inadequate. ● Large sliding heat is generated, and the oil film is thin. 	<ul style="list-style-type: none"> ● Change a sharp lip to an R-lip type. ● Change the seal to a combination seal with excellent self-lubricating properties. ● For a rod packing, add a buffer ring.
Scratch	 <p>Partial cut, dent on the edge of the lip</p>	<ul style="list-style-type: none"> ● By external force such as by hanging on a nail or wire for storage. 	<ul style="list-style-type: none"> ● Improvement to storage method
		<ul style="list-style-type: none"> ● Insufficient chamfering of the mating material when fitting. 	<ul style="list-style-type: none"> ● Increase chamfering of the mating material and make it smooth so as not to cause "overturn".
	<ul style="list-style-type: none"> ● By driver, etc. when fitting 	<ul style="list-style-type: none"> ● Use fitting tool. 	
Scratch	 <p>Scratch on sliding face.</p>	<ul style="list-style-type: none"> ● There was a scar on the mating sliding face. 	<ul style="list-style-type: none"> ● Check fully before fitting.
		<ul style="list-style-type: none"> ● Due to "overturn" of chamfered part of the mating material at the time of fitting 	<ul style="list-style-type: none"> ● Increase chamfering of the mating material and make it smooth so as not to cause "overturn".
	<ul style="list-style-type: none"> ● By embedded foreign material 	<ul style="list-style-type: none"> ● Remove foreign matter. 	

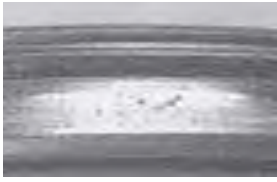
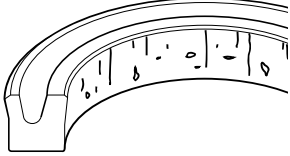
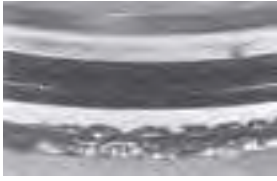
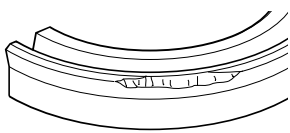
WHEN LEAKAGE OCCURS

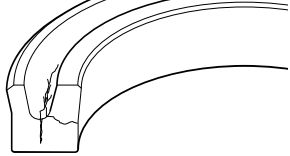

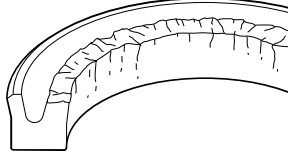

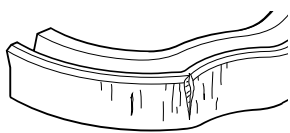

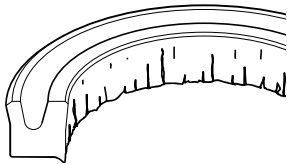

FAILURE MODE AND COUNTERMEASURES

NITRILE RUBBER PACKINGS

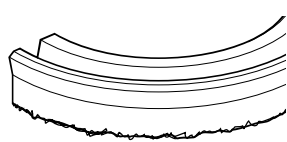
Appearance		Cause	Countermeasure
Fact	Condition		
Dents	 <p>Small dents on sliding face.</p>	<ul style="list-style-type: none"> ● Dust and cuttings embedded in the sliding face due to poor cleaning. ● Embedded foreign material or embedded oxidized products due to oxidization. 	<ul style="list-style-type: none"> ● Remove foreign materials sticking to the equipment. ● Renew oil.
			
Failure	 <p>A part of the packing lip is torn in an arc shape (piston seal).</p>	<ul style="list-style-type: none"> ● Excessive back pressure occurs. 	<ul style="list-style-type: none"> ● Change to OUHR. ● Change to SPG (SPGW).
			
	 <p>Cracks grew from the groove of packing.</p>	<ul style="list-style-type: none"> ● Fatigue failure due to frequent impulse pressure. 	<ul style="list-style-type: none"> ● In case of a rod, use buffer ring together. ● In case of a piston, change to SPG (SPGW).
		<ul style="list-style-type: none"> ● Breaking due to starting at low temperature. 	<ul style="list-style-type: none"> ● Change to packing of low temperature resistant material.
	 <p>The whole part of the lip of the sliding part is broken.</p>	<ul style="list-style-type: none"> ● Deterioration of the packing material. 	<ul style="list-style-type: none"> ● Change to heat resistant and oil resistant rubber material
		<ul style="list-style-type: none"> ● Deterioration of oil 	<ul style="list-style-type: none"> ● Renew oil.
	 <p>Broken at one or two places on the circumference of the packing.</p>	<ul style="list-style-type: none"> ● Packing installed as twisted. ● Assembled with improper packing installation. 	<ul style="list-style-type: none"> ● Improve the method and tools of installation.
			

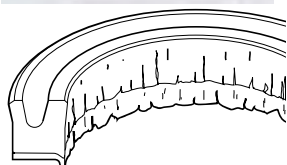
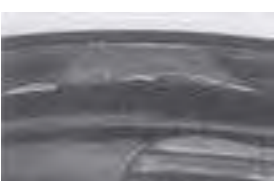
FAILURE MODE AND COUNTERMEASURES

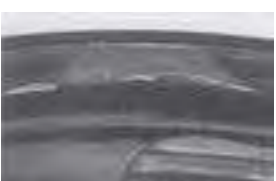





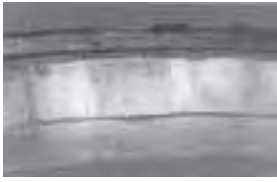
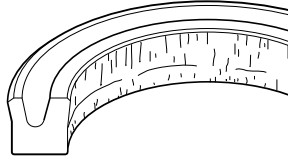

NITRILE RUBBER PACKINGS

Appearance		Cause	Countermeasure
Fact	Condition		
Extrusion	 <p>The packing heel on the sliding side is torn off.</p> 	<ul style="list-style-type: none"> ● Extrusion gap was too big. 	<ul style="list-style-type: none"> ● Reduce extrusion gap ● Use a backup ring.
	 <p>The packing heel at static side is torn off.</p> 	<ul style="list-style-type: none"> ● Bearing worn too much causing a large gap. 	<ul style="list-style-type: none"> ● Change bearing material to an appropriate material.
		<ul style="list-style-type: none"> ● Too much pressure. 	<ul style="list-style-type: none"> ● Use a backup ring together and reselect the packing. ● Use buffer ring together.
Extrusion	 <p>Extrusion at both the packing heel and the backup ring.</p> 	<ul style="list-style-type: none"> ● The construction of installation part is inappropriate 	<ul style="list-style-type: none"> ● Correct chamfering
		<ul style="list-style-type: none"> ● Gap generated due to insufficient rigidity of support plate. 	<ul style="list-style-type: none"> ● Improve rigidity of support plate
		<ul style="list-style-type: none"> ● Inappropriate backup ring. 	<ul style="list-style-type: none"> ● Correct the size of backup ring. ● Change backup ring material to appropriate one.
Excessive extrusion gap	 <p>Excessive extrusion gap</p> 	<ul style="list-style-type: none"> ● Excessive extrusion gap 	<ul style="list-style-type: none"> ● Reduce extrusion gap
		<ul style="list-style-type: none"> ● Inappropriate backup ring 	<ul style="list-style-type: none"> ● Change backup ring to that of a more rigid material. ● Make thickness of the backup ring thicker. ● Use buffer ring together.
Burning	 <p>The lip and groove are partly carbonized or melted.</p> 	<ul style="list-style-type: none"> ● Burning by adiabatic compression of the residual air. 	<ul style="list-style-type: none"> ● Countermeasures shown on pages 262 and 263.

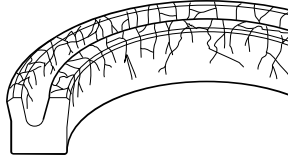
WHEN LEAKAGE OCCURS

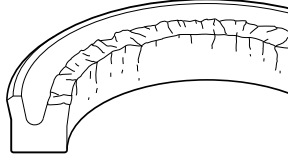
FAILURE MODE AND COUNTERMEASURES

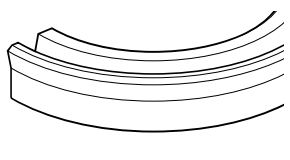

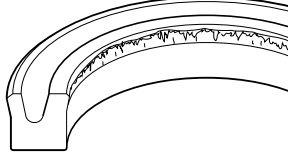



IRON RUBBER PACKINGS

Appearance		Cause	Countermeasure
Fact	Condition		
Deterioration	 <p>Gloss and cracks on the surface. Push with a finger and cracks appear.</p> 	<ul style="list-style-type: none"> Excessive rise of oil temperature. Incompatibility of oil and rubber material. Deterioration of oil 	<ul style="list-style-type: none"> Lower oil temperature or change to heat resistant material (fluorine rubber) Check oil resistance of the packing and change the material of the packing or the hydraulic oil. Renew oil.
	 <p>Rubber loses elasticity and breaking off.</p> 	<ul style="list-style-type: none"> Excessive rise of oil temperature. Incompatibility of oil and rubber material. Deterioration of oil. 	<ul style="list-style-type: none"> Change to rubber material with better heat and oil resistance. Check oil resistance of the packing and change the material of the packing or the hydraulic oil. Renew oil
	 <p>The whole part of the lip of the sliding part is torn off.</p> 	<ul style="list-style-type: none"> Excessive rise of oil temperature. Incompatibility of oil and rubber material Deterioration of oil. Deterioration of oil. 	<ul style="list-style-type: none"> Change rubber material to the one with better heat resistance. Check oil resistance of the packing and change the material of the packing or the hydraulic oil. Renew oil.
Wear	 <p>Wear with gloss on the sliding surface.</p> 	<ul style="list-style-type: none"> Sliding was extremely short stroke and caused insufficient lubrication. Pressure higher than 3MPa is always exerted. 	<ul style="list-style-type: none"> In case of a piston, change to SPG (SPGW). In case of a rod, use buffer ring together. In case of a piston, change to SPG (SPGW). In case of a rod, use buffer ring together. Check the piping resistance and change the piping structure to lower the pressure.
	 <p>Abnormal wear at part of the circumference of the sliding lip (matching the direction of lateral load).</p> 	<ul style="list-style-type: none"> Abnormal wear of wear ring (piston) and bearing by excessive lateral load. 	<ul style="list-style-type: none"> Change wear ring and bearing material to those which can withstand a heavy load.

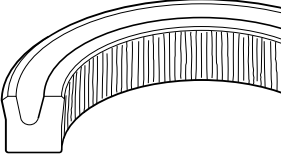
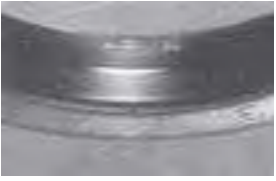
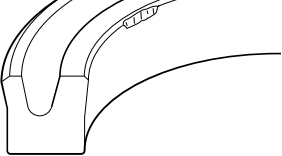
WHEN LEAKAGE OCCURS

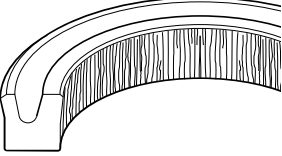
FAILURE MODE AND COUNTERMEASURES

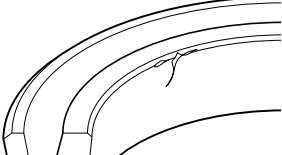

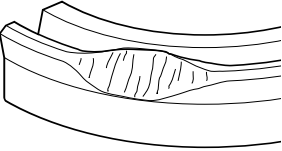



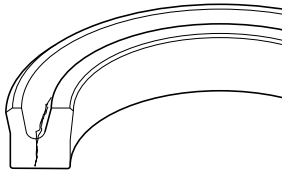

IRON RUBBER PACKINGS

Appearance		Cause	Countermeasure
Fact	Condition		
Wear	 <p>The sliding surface has worn in a striation pattern.</p> 	<ul style="list-style-type: none"> ● The seal slides at an extremely short stroke, and the shape of the lubricating oil film is inadequate. ● Large sliding heat is generated, and the oil film is thin. 	<ul style="list-style-type: none"> ● Change a sharp lip to an R-lip type. ● Change the seal to a combination seal with excellent self-lubricating properties. ● For a rod packing, add a buffer ring.
	 <p>Partial cut, dent on the edge of the lip</p> 	<ul style="list-style-type: none"> ● By external force such as by hanging on a nail or wire for storage. ● Cut and dent due to "overturn" of the mating material when fitting. ● Cut and dent by driver, etc. when fitting 	<ul style="list-style-type: none"> ● Improvement to storage method ● Increase chamfering of the mating material and make it smooth so as not to cause "overturn". ● Use fitting tool.
Scars	 <p>Scratches on sliding face.</p> 	<ul style="list-style-type: none"> ● There was a "scar" on the mating sliding face. ● Due to "overturn" of chamfered part of the mating material at the time of fitting ● By embedded foreign material 	<ul style="list-style-type: none"> ● Check fully before fitting. ● Increase chamfering of the mating material and make it smooth so as not to cause "overturn". ● Remove foreign matter.
	 <p>Generation of "scratches" at edge of the lip.</p> 	<ul style="list-style-type: none"> ● Due to "overturn" of chamfered part of the mating material at the time of fitting 	<ul style="list-style-type: none"> ● Chamfer the mating material according to the Dimensional Table and make it smooth so as not to cause "overturn".
	 <p>The sliding lip of packing is extruded in an arc shape or torn off. (piston seal)</p> 	<ul style="list-style-type: none"> ● Generation of excessive back pressure. 	<ul style="list-style-type: none"> ● In case of Iron rubber packing, change to OUIS. ● Change to combination seal (SPG, SPGW).

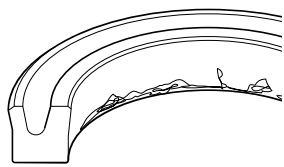
WHEN LEAKAGE OCCURS

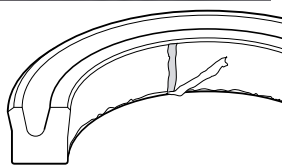
FAILURE MODE AND COUNTERMEASURES

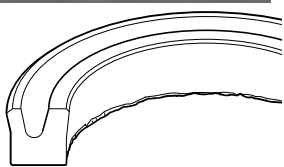
IRON RUBBER PACKINGS

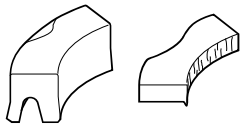
Appearance		Cause	Countermeasure
Fact	Condition		
Failure	 <p>Generation of cracks starting from the groove of U packing.</p> 	<ul style="list-style-type: none"> ● Fatigue failure due to frequent shock pressure. 	<ul style="list-style-type: none"> ● In case of a rod packing, use buffer ring together. ● In case of a piston, change to SPG (SPGW).
	Extrusion	 <p>Heel part on sliding side is torn off.</p> 	<ul style="list-style-type: none"> ● Excessive extrusion gap. ● Increase of bearing gap due to great wear of bearing. ● Excessive pressure.
 <p>Trace of small dent exists from the heel side of the sliding surface to the edge of the lip and a thin film like extrusion fraction is left on the heel part.</p> 		<ul style="list-style-type: none"> ● Excessive extrusion gap ● Excessive pressure 	<ul style="list-style-type: none"> ● Reduce the gap. ● Use backup ring together. ● Use backup ring together and re-select packing. ● Use buffer ring together
 <p>The heel part of the sliding side shows extrusion and change of color into red all over.</p> 		<ul style="list-style-type: none"> ● Excessive extrusion gap ● Increase of bearing gap due to a significant wear of bearing. ● Excessive pressure 	<ul style="list-style-type: none"> ● Reduce the extrusion gap. ● Use backup ring together. ● Change bearing material to an appropriate one. ● Use backup ring together and re-select packing. ● Use buffer ring together.
 <p>The out side of the pure PTFE backup ring is partially torn off, from where packing has extruded and deformed.</p> 		<ul style="list-style-type: none"> ● Insufficient strength and wear resistance of the backup ring. 	<ul style="list-style-type: none"> ● Change material of backup ring to 19YF or 80NP.

WHEN LEAKAGE OCCURS



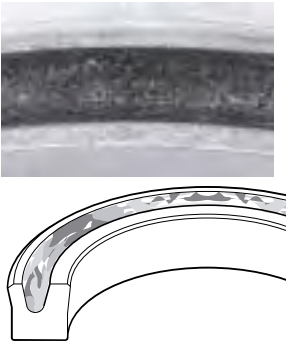
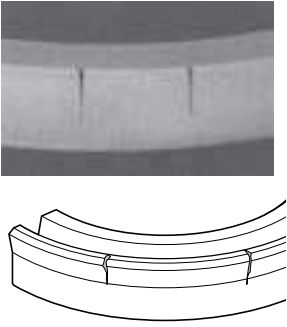

■ FAILURE MODE AND COUNTERMEASURES

IRON RUBBER PACKINGS

Appearance		Cause	Countermeasure
Fact	Condition		
Burning	 <p>Groove of U packing is partially burned and carbonized.</p>	<ul style="list-style-type: none"> ● Burning by adiabatic compression of the residual air. 	<ul style="list-style-type: none"> ● Countermeasures shown on pages 262 and 263.
Deformation	 <p>Deformation and cuts at 2 places on the out side of the packing.</p>	<ul style="list-style-type: none"> ● Poor installation in the integrated groove 	<ul style="list-style-type: none"> ● Shown on page 232.

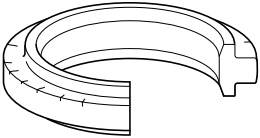

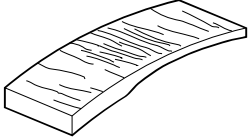
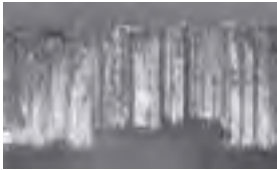
FAILURE MODE AND COUNTERMEASURES

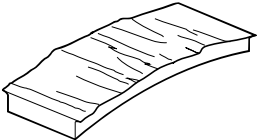
COMBINATION SEALS

Appearance		Cause	Countermeasure
Fact	Condition		
Deterioration	 <p>Cracking has occurred in the back ring.</p>	<ul style="list-style-type: none"> ● The back ring has been used at a high temperature 	<ul style="list-style-type: none"> ● Change the back ring material to one with excellent heat resistance.
			
Wear	 <p>A part of circumference of the seal is abnormally worn (matching with the direction of lateral load)</p>	<ul style="list-style-type: none"> ● Eccentricity due to abnormal wear of wear ring and bearing caused by an excessive lateral load. 	<ul style="list-style-type: none"> ● Change the material of wear ring and of bearing to the one that can resist against the lateral load.
		<ul style="list-style-type: none"> ● Sliding face of the mating material is partly rough. 	<ul style="list-style-type: none"> ● Finish roughness uniformly (Recommended value: 0.4 ~ 3.2 μm Rz).
Scars	 <p>Heavy scratches on sliding surface.</p>	<ul style="list-style-type: none"> ● There was a "scar" on the mating sliding face. 	<ul style="list-style-type: none"> ● Check fully before fitting.
		<ul style="list-style-type: none"> ● Due to "burr" and "overturn" of chamfered part of the mating material at the time of fitting. 	<ul style="list-style-type: none"> ● Increase chamfering of the mating material according to Dimensional Table and make it smooth so as not to cause "bur" and "overturn".
		<ul style="list-style-type: none"> ● By embedded foreign material such as metal powder, etc. 	<ul style="list-style-type: none"> ● Remove foreign materials. ● Provide contamination seals (KZT) on both sides of the packing.
Extrusion (Rarefion ring)	 <p>Film-like extrusion on the sliding surface of the seal.</p>	<ul style="list-style-type: none"> ● Excessive extrusion gap 	<ul style="list-style-type: none"> ● Reduce extrusion gap ● Change material to the one with higher rigidity ● Change to SPGW with backup ring.
			

FAILURE MODE AND COUNTERMEASURES

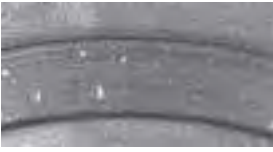
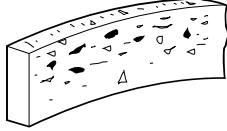
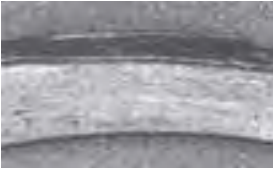
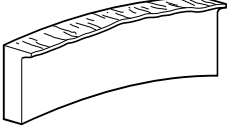
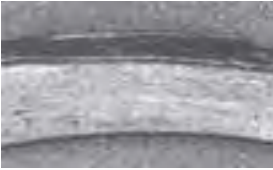
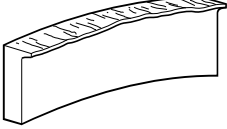
PARTS CONNECTED WITH SEALS

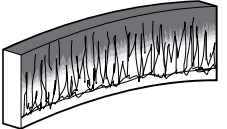
Appearance		Cause	Countermeasure
Fact	Condition		
Burying of foreign material Dents	  <p>Foreign material is embedded in seal and backup ring.</p>	<ul style="list-style-type: none"> ● Existence of foreign material in oil and in pipings. 	<ul style="list-style-type: none"> ● Remove foreign matter. ● Provide contamination seals (KZT) on both sides of the packing.
	  <p>Extrusion has occurred in the backup ring.</p>	<ul style="list-style-type: none"> ● Production of metal powder as a result of seizure of piston and cylinder. 	<ul style="list-style-type: none"> ● Change the material of wear ring and of bearing to the one that can resist against the lateral load.
Extrusion (Backup ring)	  <p>Extrusion has occurred in the backup ring.</p>	<ul style="list-style-type: none"> ● Excessive extrusion gap ● High pressure 	<ul style="list-style-type: none"> ● Reduce extrusion gap ● Change the material of the backup ring to the one with higher rigidity.
Burning	  <p>One side of the wear ring is carbonized.</p>	<ul style="list-style-type: none"> ● Burning by adiabatic compression of the residual air. 	<ul style="list-style-type: none"> ● Countermeasures shown on pages 262 and 263.

WHEN LEAKAGE OCCURS



TECHNICAL DATA

JIS STANDARDS FOR LEAKAGE AMOUNT	252
PISTON PACKING LEAKAGE AND WEAR	253
ROD PACKING LEAKAGE AND WEAR	254
MINIMUM OPERATING PRESSURE	255
FRictional RESISTANCE	256~257
LOW TEMPERATURE RESISTANCE PACKINGS	258
BUFFER RINGS	259
PACKINGS FOR EXTREMELY SHORT STROKES	260~261
PHENOMENON OF BURNING	262~263
STICK/SLIP	264
BREAKAGE DUE TO PRESSURE BUILD-UP	265
BLOW-THROUGH LEAKAGE (PASSING)	266
SWELLING MECHANISM	267
ROUGHNESS OF CONTACTING OBJECT	268
SEALING SYSTEM (COMBINATION EFFECT)	269
BLISTERS	270

1. JIS STANDARDS FOR LEAKAGE AMOUNT (Old JIS B 8354 :1992)

PISTON PACKING (INTERNAL OIL LEAKAGE)

Old JIS B 8354:1992 states that, when the maximum pressure is applied to one side of an immobilized piston, the amount of oil leakage to the other side of the piston must be less than those listed in the **Table H-1**, under the test condition shown in the right. With combined seals (SPG, SPGW), the amount of the internal oil leakage must be less than twice the figures in **Table H-1**.

Testing Conditions

Oil used : Hydraulic oil, unless specified, shall be equivalent to JIS K 2213 class 2 (additive turbine oil) with viscosity grade VG32 or VG46.
 Oil temperature : $50 \pm 5^\circ\text{C}$ unless specified otherwise.
 Piston speed : 0

<Table H-1> Acceptable amount of internal oil leakage for piston packings

Unit : ml/10min

I.D. (mm)	Amount of oil leakage	I.D. (mm)	Amount of oil leakage	I.D. (mm)	Amount of oil leakage
32(31.5)	0.2	100	2.0	200	7.8
40	0.3	125	2.8	220(224)	10.0
50	0.5	140	3.0	250	11.0
63	0.8	160	5.0		
80	1.3	180	6.3		

* Acceptable leakage amount for combined seal is double of the listed value.

ROD PACKING (EXTERNAL OIL LEAKAGE)

Old JIS B 8354:1992 states "that there should be no leakage, except from the rod, under any operating condition, when piston makes reciprocating motion under the test condition as described below with regard to external oil leakage of hydraulic cylinder." Oil leakage from rod is classified into Type A, Type B and Type C as given in **Fig. H-1**.

<Table H-2> PISTON SPEED

Cylinder tube I.D. (mm)	Piston speed (mm/s)
32 40 50 63	8 ~ 400
80 100 125	8 ~ 300
140 160 180 200 220 250	8 ~ 200

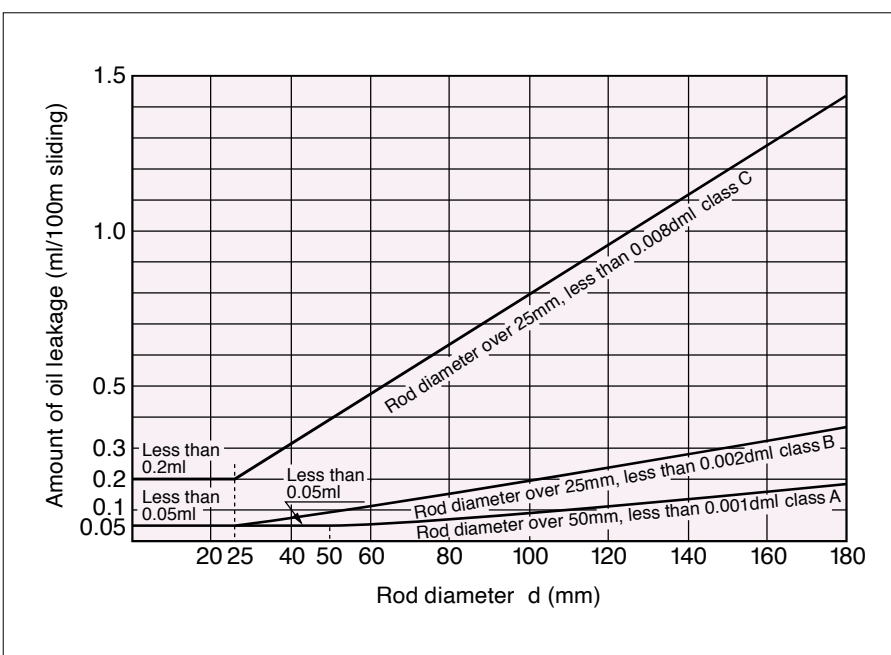

<Fig. H-1> Acceptable external oil leakage

Test conditions

Oil used : Hydraulic oil, unless specified, shall be equivalent to JIS K 2213 class 2 (additive turbine oil) with viscosity grade VG32 or VG46.

Temperature of oil : $50 \pm 5^\circ\text{C}$ unless otherwise specified

Piston speed : To be decided according to the inside diameter of the cylinder tube. (Table H-2)

Internal pressure : internal pressure generated in the cylinder shall not exceed, at any moment during the test, the maximum operating pressure except hydraulic pressure test.

2. AMOUNT OF WEAR AND OIL LEAKAGE OF PISTON PACKINGS

Relationship between internal surface roughness of the cylinder tube and amount of wear

Fig. H-2 shows the relationship between internal surface roughness of the cylinder tube and the amount of wear for piston packings (SPG, OSI, and OUHR).

Test conditions

Pressure : 17.7MPa {180kgf/cm²}
(Constant)
Stroke : 100mm
Piston speed : 100mm/s
Oil used for test : Turbine oil grade 2
Temperature of oil : 60 ~ 70°C
(In the tank)
Tube inside diameter : φ100
Sliding distance : After sliding 80 km

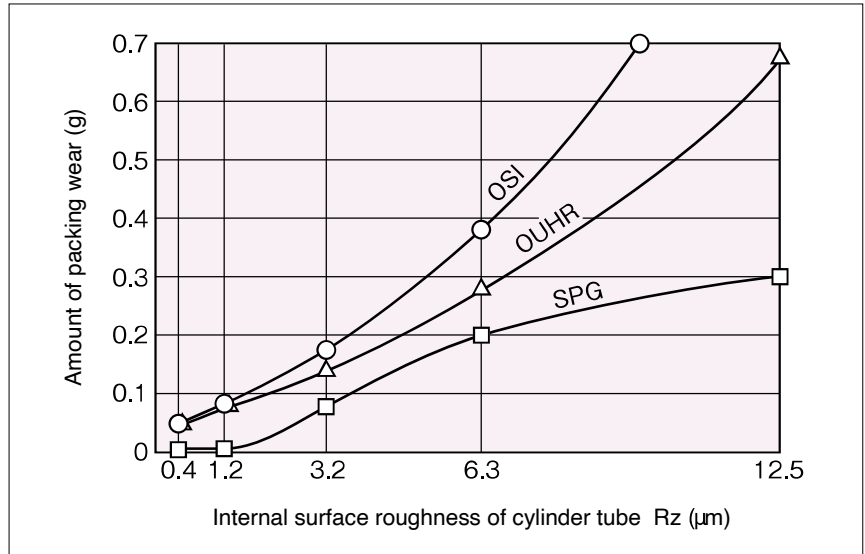

〈Fig. H-2〉 Acce

- Packings for high wear resistance such as SPG are suitable for use with the types of hydraulic cylinders which can allow some internal oil leakage.
- It is recommended to finish the internal surface of cylinder tube at 0.4 - 3.2 μm Rmax.

Relationship between internal surface roughness of the cylinder tube and amount of wear

Fig. H-3 shows the relationship between internal surface roughness of the cylinder tube and the amount of oil leakage for piston packings (SPG, OSI, and OUHR).

Test conditions

Pressure : 17.7MPa {180kgf/cm²}
(Constant)
Stroke : 100mm
Piston speed : 100mm/s
Oil used for test : Turbine oil grade 2
Temperature of oil : 60 ~ 70°C
(In the tank)
Tube inside diameter : φ100
Sliding distance : After sliding 80 km

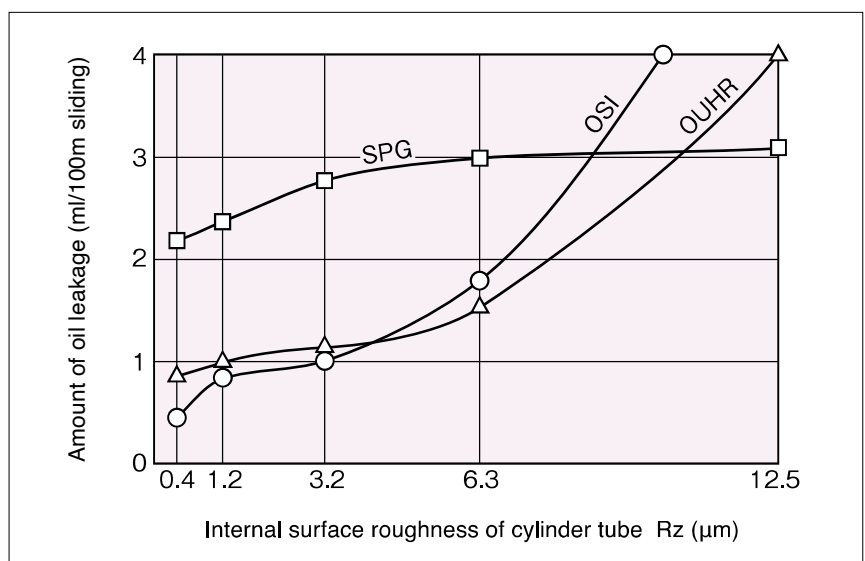

〈Fig. H-3〉 Acce

- Old JIS B 8354:1992 allows the internal oil leakage at static condition as shown in the Table H-1, but no internal oil leakage has been found on any packings with this test.

3. AMOUNT OF WEAR AND OIL LEAKAGE OF ROD PACKINGS

Relation between rod surface roughness and amount of wear

Fig. H-4 shows the relationship between rod surface roughness and amount of wear of U packings (UPH, USI and IDI).

Test conditions

Pressure : 0 ~ 13.7MPa
 {0 ~ 140kgf/cm²}
 Stroke : 200mm
 Rod speed : 500mm/s
 Oil used for test : Turbine oil
 grade 2
 Temperature of oil : 100°C
 Rod diameter : φ50
 Sliding distance : After sliding 1000 km

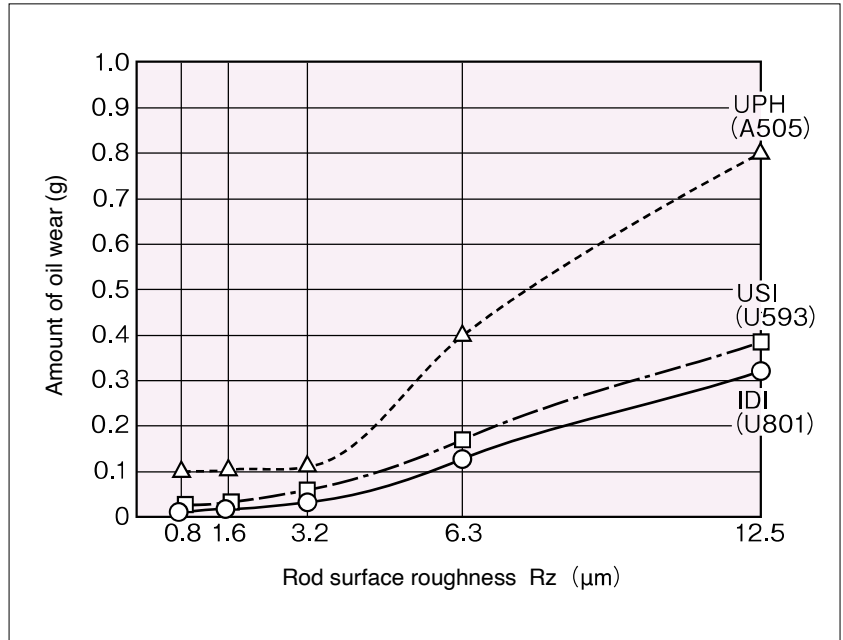

〈Fig. H-4〉 Rod Surface Roughness and Amount of Wear

- When the rod surface is too rough, the amount of wear of rod packing will increase. Therefore, it is suggested to finish it to 0.8 ~ 1.6μm Rz

Relationship between rod surface roughness and amount of oil leakage

Fig. H-5 shows the relationship between rod surface roughness and the amount of oil leakage for U packings (UPH, USI, and IDI).

Test conditions

Pressure : 0 ~ 13.7MPa
 {0 ~ 140kgf/cm²}
 Stroke : 200mm
 Rod speed : 500mm/s
 Oil used for test : Turbine oil
 grade 2
 Temperature of oil : 100°C
 Rod diameter : φ50
 Sliding distance : After sliding 1000 km

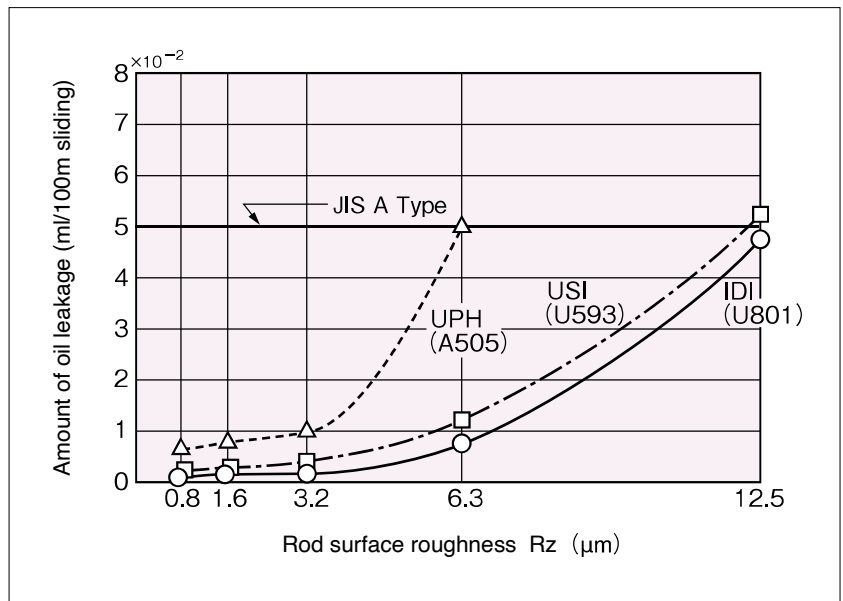

〈Fig. H-5〉 Rod surface roughness and amount of oil leakage

- As the rod surface roughness affects the oil leakage, it is suggested to finish to 0.8 ~ 1.6μm Rz

4. MINIMUM OPERATING PRESSURE

Fig. H-6 shows an example of actual measurement of the minimum operating pressure of piston packings (ODI, UPI, UPH, OUHR and SPG).

Test conditions

Cylinder tube I.D. : $\phi 100$
 Rod diameter : $\phi 70$
 Rod packing : UPH 70×90×15
 Dust seal : DKB 70×84×8×11
 Pressurizing board : Cylinder head side

Cylinder operating conditions

Pressure : 0 ~ 16.7MPa
 { 0 ~ 170kgf/cm² }
 Stroke : 650mm
 Speed : 650mm/s (Average)
 Oil used : Turbine oil grade 2
 Oil temperature : 80°C (Maximum)

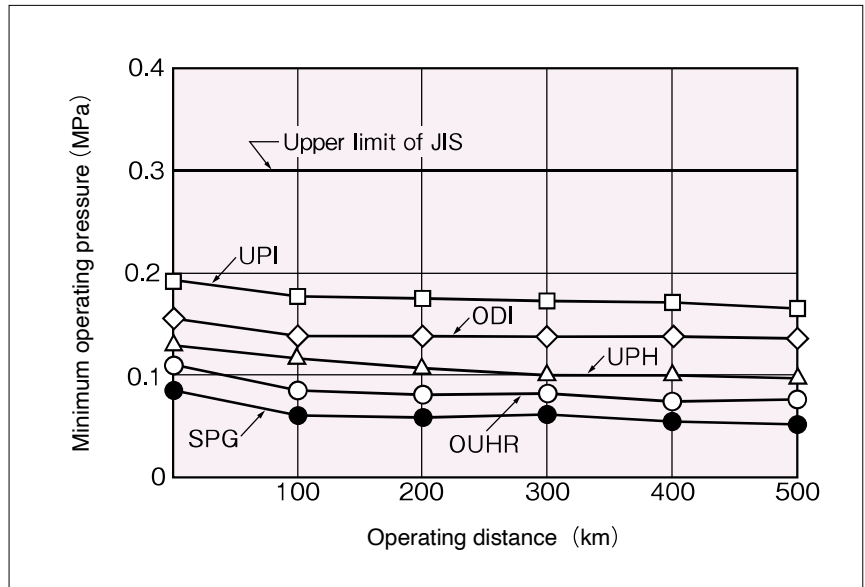

〈Fig. H-6〉 Example of actual measurement of the minimum operating pressure

- As NOK Rareflon is used for sliding material of SPG packing, and self-lubrication property of OUHR packing is improved, the operating pressure for the both shows low values.

WHAT IS MINIMUM OPERATING PRESSURE

The minimum pressure is required to ensure the operation of the cylinder. When the pressure is applied from the head side \textcircled{H} or the rod side \textcircled{R} of the cylinder without any load as shown in the Fig. H-7, the minimum pressure required to allow a smooth operation of the piston at the minimum speed (8mm/sec) shown in the Table H-2 is called the minimum operating pressure. Old JIS B 8354:1992 (Hydraulic cylinder) prescribes this minimum operating pressure. Table H-3 shows the minimum operating pressure in the case when the pressure is applied from the cylinder head side. According to Old JIS B

8354:1992, "When the minimum operating pressure is required lower than specified below, the said value can be modified under an agreement between the parties concerned for delivery".

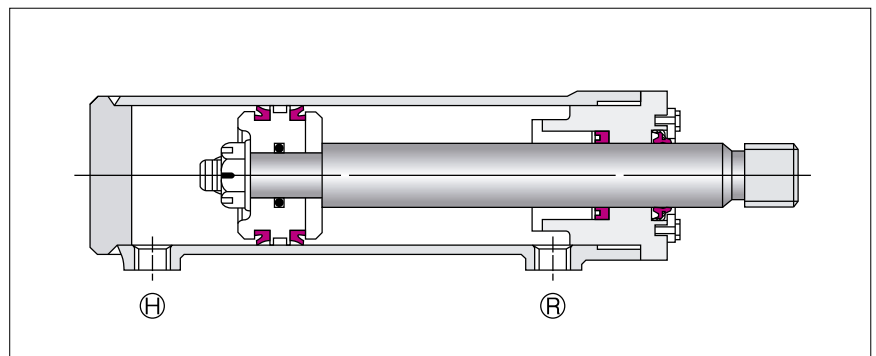

〈Fig. H-7〉 Example of cylinder used for measuring the minimum operating pressure.

〈Table H-3〉 Example of JIS Minimum Operating Pressure (when the pressure is applied from the cylinder head side).

Unit : MPa

Shape of piston packing	Nominal pressure	Shape of rod packing		Remark
		Other than V packing	V packing	
V packing	3.5 , 7	0.5	0.75	The minimum operating pressure when the pressure, is applied from the rod side, is defined by the classification of rod diameter.
	14 , 21	Nominal pressure×6%	Nominal pressure×9%	
U,L Packing, X ring, O ring, combination seal	3.5 , 7	0.3	0.45	
	14 , 21	Nominal pressure×4%	Nominal pressure×6%	
Piston ring	3.5 , 7	0.1	0.15	
	14 , 21	Nominal pressure×1.5%	Nominal pressure×2.5%	

5. FRICTIONAL RESISTANCE

Fig. H-8 shows an example of actual measurement of frictional resistance of piston packings (SPG, UPH, and OUHR).

Test conditions

I.D. of cylinder tube : $\phi 100$
 Piston speed : 300mm/s
 Oil used : Turbine oil grade 2 (ISO VG46)
 Oil temperature : 60°C

Test equipment

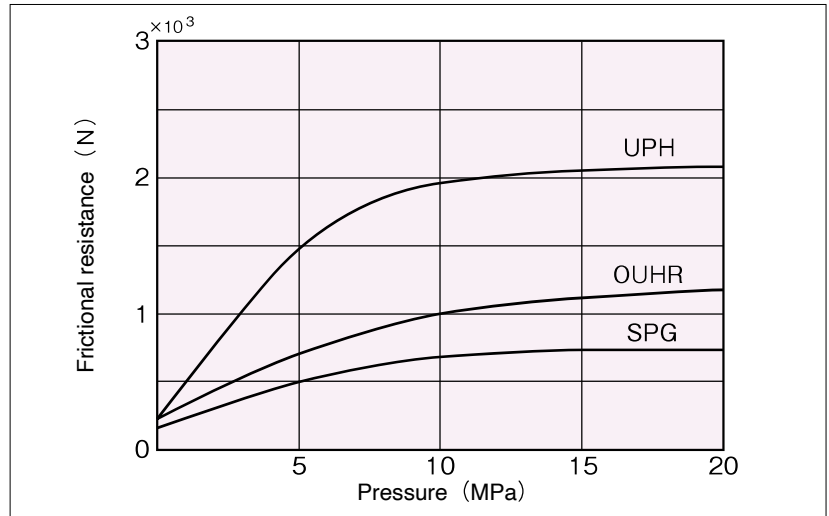
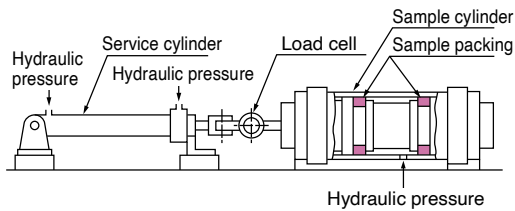

〈Fig. H-8〉 Frictional resistance and Pressure

● Use SPG or SPGW for piston packing for low friction.

■ Shape of lip edge with U packing that affects frictional resistance and sealing performance.

Frictional resistance and sealing performance vary with the lip shape of U packings as shown in Fig. H-9 and Fig. H-10.

	OUHR ($\phi 120$) packing	USH ($\phi 120$) packing
Sample packing		

Measuring conditions of frictional resistance

Temperature : 80°C constant
 Pressure : 0, 2, 3.4, 4.9, 6.4MPa
 {0, 20, 35, 50, 65kgf/cm²}
 Speed : 75mm/s
 Stroke : 20mm
 Oil used : Turbine oil grade 2 (ISO VG46)

Impulse endurance test conditions

Temperature : 100°C
 Pressure : 0 ~ 24.5 ~ 36.8MPa
 {0 ~ 250 ~ 375kgf/cm²}
 Frequency of pressurization : 70c.p.m
 Number of pressurization : 600,000 times
 Speed : 150mm/s
 Stroke : 150mm
 Oil used : Turbine oil grade 2 (ISO VG46)

● Recommend to use OUHR packing with improved self-lubrication property as the piston U packing for low friction.

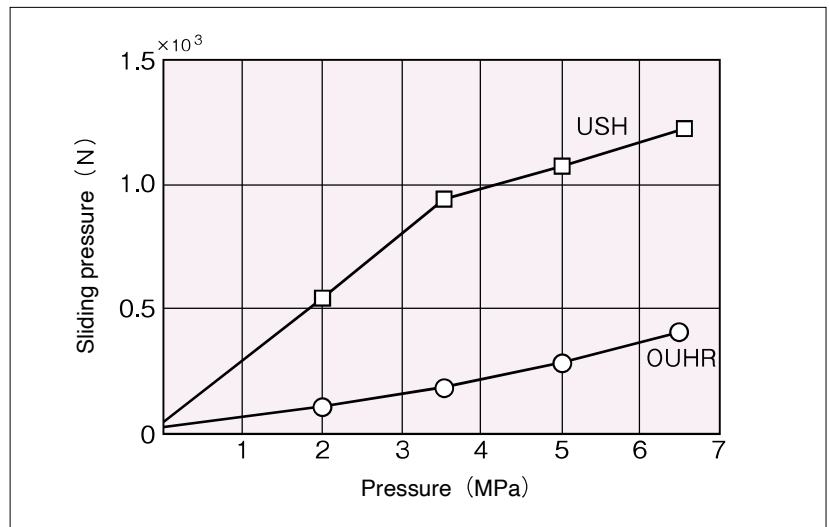

〈Fig. H-9〉 Frictional resistance and pressure

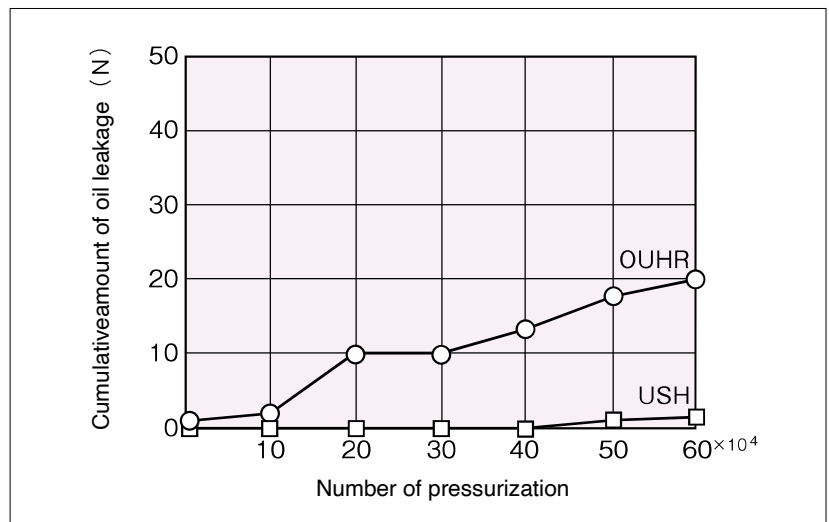

〈Fig. H-10〉 Number of pressurization and amount of oil leakage

HOW TO CALCULATE FRICTIONAL RESISTANCE OF PACKINGS

Frictional resistance can be calculated from the following formula.

$$F = f \times Pr \quad \dots\dots\dots (5)$$

Where,

- F : Frictional resistance (N)
- f : Frictional coefficient
- Pr : Packing radial force (N)

Therefore, in order to find the frictional resistance, it is necessary to know the values of frictional coefficient and packing radial force. To obtain the friction coefficient *f*, use the non-dimensional characteristic diagram in **Fig. H-11**, *G* in accordance with operating condition and read the value *f*.

Use Formula (6) to find out the radial force of a packing when pressure is applied.

$$Pr = \pi dbp + Pro \quad \dots\dots\dots (6)$$

Where,

- d : Rod diameter (cm)
- b : Contact width (cm)
- p : Applied pressure (Pa)
- Pro : Radial force of packing under ambient pressure (N)

(The value *Pro* varies with the shape and material of packings. **Fig. H-12** shows, for your reference, an example of actual measurement of radial force of representative packings. As the applied pressure becomes higher, *Pro* becomes a negligible value in function to πdbp in the formula (6).

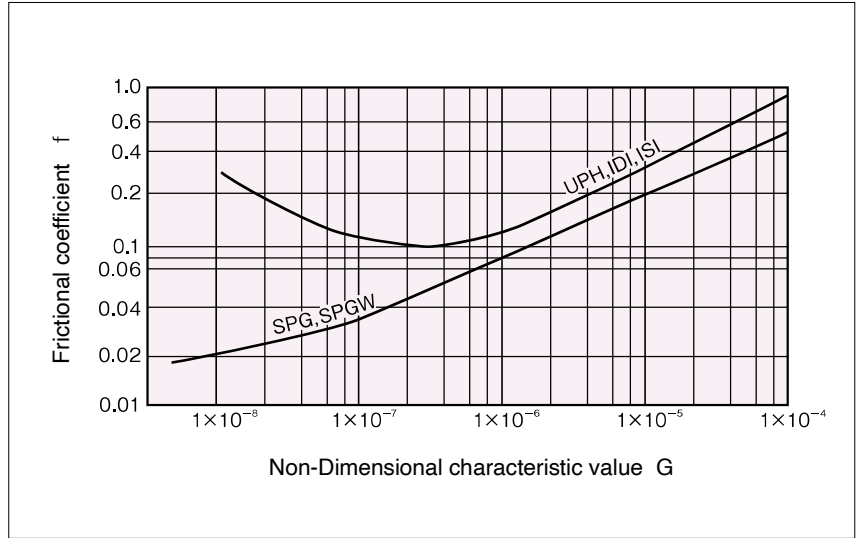

<Fig. H-11> Dimensionless characteristic diagram

● Please refer to Page 12 for calculating method of the dimensionless characteristic number *G*.

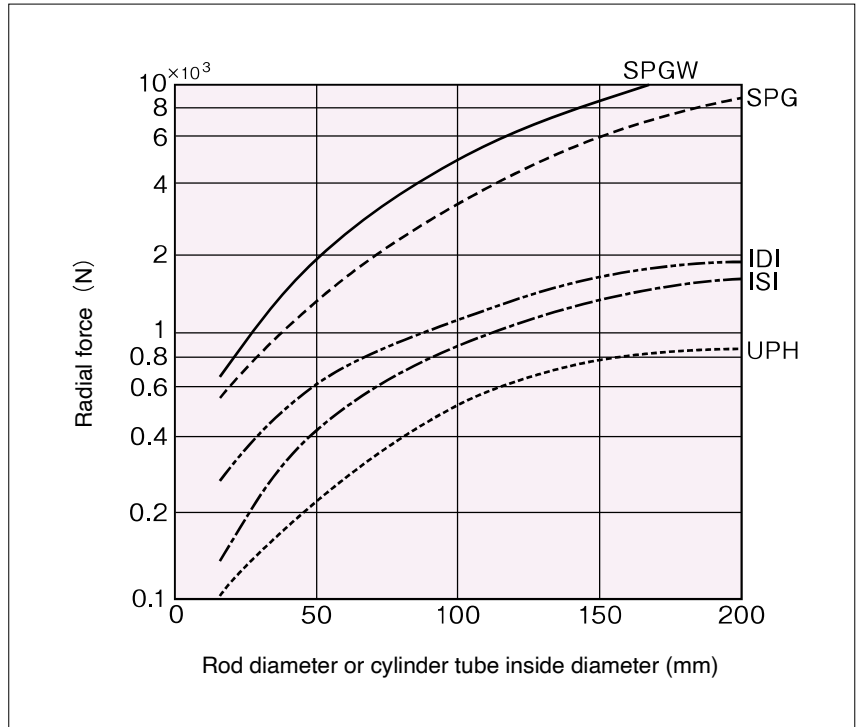

<Fig. H-12> Radial force of packing (Under ambient pressure)

TECHNICAL DATA

6. LOW TEMPERATURE RESISTANCE PACKINGS

The standard rubber material for NOK packings (material code A505, U801) aims at about -30°C as limit temperature for low temperature usage. In low temperature areas, the rubber packing material's elasticity decreases and its sealing performance becomes unstable. As the packing lip's ability to follow the eccentricity of the rod decreases, it becomes important to reduce the amount of eccentricity of the rod. When using packings in a low temperature area, minimize rod eccentricity, and apply a low temperature resistance packing.

EFFECT OF ECCENTRICITY ON SEALING PERFORMANCE AT A LOW TEMPERATURE

Table H-4 and Table H-5 show an example of test results with low temperature resistant U packings and standard U packings.

〈Table H-4〉 Cold resistant U packings

Sample packing	IUH 75 85 6 (A567) Low temperature resistant nitrile rubber					UNI 75 88 10 (① U801 ② S813)				
	-40	-45	-50	-55	-60	-40	-45	-50	-55	-60
Amount of eccentricity (TIR) (°C)										
0.15mm	○	○	○	○	△	○	○	○	○	△
0.30mm	○	○	○	○	△	○	○	△	△	●
0.45mm	○	○	△	△	●	△	△	△	●	●

〈Table H-5〉 Standard U packings

Sample packing	IUH 75 85 6 (A505)			ISI 75 85 6 (U801)	
	-15	-20	-25	-30	-35
Amount of eccentricity (TIR) (°C)					
0.15mm	○	○	○	○	△
0.30mm	○	○	○	○	△
0.45mm	○	○	△	△	●

○...No oil leakage △...Oil leakage while sliding ●...Oil leakage at static

Test conditions
 Sample : U packing for rod diameter φ75
 (Dipped in oil at 100°C for 70H prior to the test)
 Pressure : 2MPa [20kgf/cm²] (constant pressure)
 Stroke : 20mm
 Cycle : 1 c.p.s
 Oil used for test : Hydraulic oil for extra low temperature
 Test duration : After leaving the test piece for 15 hours at each temperature, stroke for 15 minutes.

As the eccentricity affects sealing performance at low temperature, use H9/f8 fit for bush or bearing.

EFFECT OF LOW TEMPERATURE HYDRAULIC OIL FOR INITIAL FRICTIONAL RESISTANCE

Some low temperature hydraulic oil increase the frictional resistance of packings. This is caused by remaining dried additives in oil. Fig. H-13 shows an example of measuring the initial frictional resistance with low temperature oil.

Sample packing : IUH type packing (Material : A567)

Test conditions
 Temperature : 25°C
 Pressure : Ambient pressure
 Speed : 250mm/s
 Stroke : 50mm
 Oil used : ① MIL H 5606E
 ② Engine oil for low temperature
 ③ Turbine oil grade 2 (ISO VG32)
 Time for leaving sample : 0, 12, 48, 72 (H)

Leaving conditions
 By making rod to perform several stroke, let the oil film deposited on the rod surface and leave the packing as it is at room temperature.

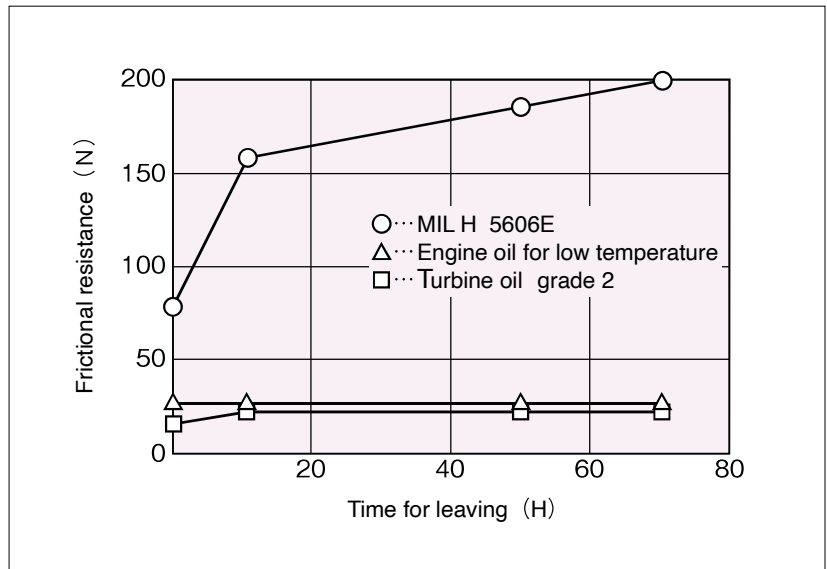

〈Fig. H-13〉 Result of measurement of initial frictional resistance

7. BUFFER RINGS

Buffer rings (HBY and HBTS) are inserted in the pressure side of rod packings to protect and improve packing durability. Also, under extremely short stroke conditions, they help prevent abnormal wear of rod packings.

- 3 effects of buffer rings**
- (1) To buffer the impact pressure generated on the rod side of a hydraulic cylinder.
 - (2) To inhibit transmission of oil temperature to rod packings.
 - (3) To reduce frictional resistance and generation of sliding heat of rod packings.

Buffer ring does not generate accumulated pressure between rod packings, because of back pressure relief property.

EXAMPLE OF BUFFERING EFFECT ON IMPACT PRESSURE

Test conditions	Construction (rod sealing system)	Conditions after test
Rod diameter : $\Phi 70$ Pressure : $0 \sim 41.2\text{MPa}$ { $0 \sim 420\text{kgf/cm}^2$ } Speed : 530mm/s Stroke : 900mm Oil used : Turbine oil grade 2 (ISO VG46) Oil temperature : $90 \pm 5^\circ\text{C}$ (in the tank) Sliding distance : After sliding 250 km	With a buffer ring 	HBYS: Fine wear IUH: No wear BRT2: No extrusion
	With a buffer ring 	HBTS: Fine extrusion IUH: No wear BRT2: No extrusion
	Without a buffer ring 	IUH: Wear BRT2: Extrusion

EXAMPLE OF REDUCTION OF TEMPERATURE AT SLIDING AREA

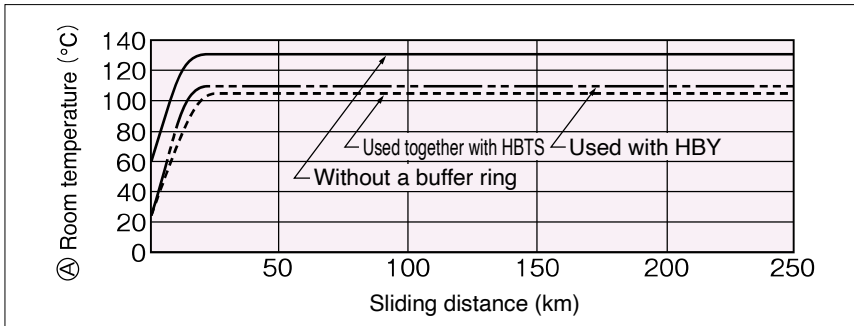

- When the impact pressure and the oil temperature are high, reduction of pressure and temperature of sliding part can be obtained by using a buffer ring.
- It is recommended to use packing and buffer ring together.

(Fig. H-14) An example of measurement of temperature at sliding area (For test conditions and temperature at $\text{\textcircled{A}}$, refer to the test condition.)

EXAMPLE OF REDUCTION OF FRICTIONAL RESISTANCE

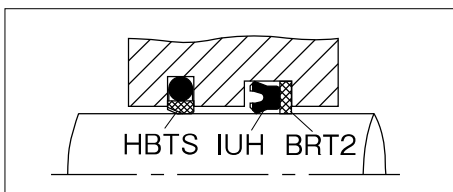

Test conditions
 Pressure : $0 \sim 9.8\text{MPa}$
 { $0 \sim 100\text{kgf/cm}^2$ }
 Speed : 30mm/s
 Stroke : 100mm
 Oil used : General purpose hydraulic oil
 Temperature : Constant temperature at 80°C

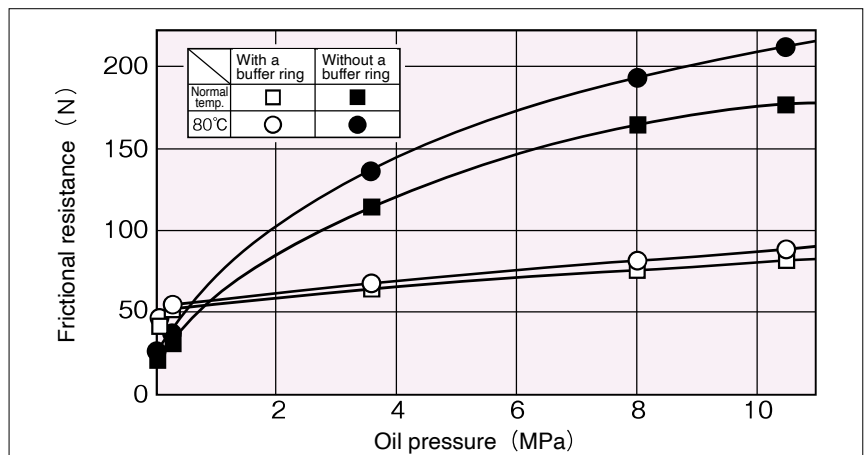

(Fig. H-15) Relation between hydraulic pressure and frictional resistance

8. PACKINGS FOR EXTREMELY SHORT STROKE

When packings are used with extremely short strokes, breaking of oil film (out of lubricant) occurs, and abnormal wear of the packing may occur. To prevent this, the packing must be designed to allow an easy formation of the lubricant film and to use material with better wear resistance.

Extremely short stroke roughly means a stroke below "the minimum stroke of 25 mm" defined in the old JIS B 8354 : 1992.

PISTON PACKINGS

Test method

In order to investigate the internal oil leakage amount, test was conducted with the condition below. The oil leakage was measured at 250,000, 500,000, 750,000 and 1,000,000 cycles. The amount of oil leakage inside the test sample packing is measured by measuring the amount of oil leakage from the head-side (H) port when a given pressure of 34.3 MPa {350kgf/cm²} is applied from the rod-side (R) port for 10 minutes as shown in Fig. H-16.

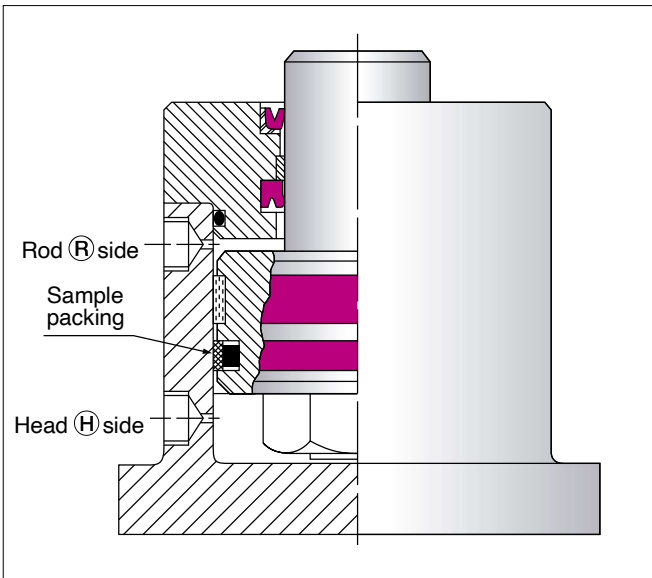

〈Fig. H-16〉 Test equipment

Sample packing

Cross section of seal	Type and size	Material
	SPG 94 110 7.3	① 19YF ② A980
	OSI 110 95 9	U801
	OUHR 110 95 9 BRT2 95 110 3	① A567 ② 19YF

Test condition

Oil used : General purpose hydraulic oil
 Pressure : Rod (R) side
 0 ~ 34.3MPa {0 ~ 350kgf/cm²}
 Head (H) side
 0 ~ 2MPa {0 ~ 20kgf/cm²}
 Stroke : 2mm
 Cycle : 16 c.p.m (Average speed 4mm/s)
 Sliding cycle : 100×10⁴ times
 Temperature : 95±5°C (at cylinder internal surface)
 Roughness of cylinder internal surface : 3.2μm Rmax

Test results

※ The amount of internal oil leakage for SPGW is almost the same as SPG.

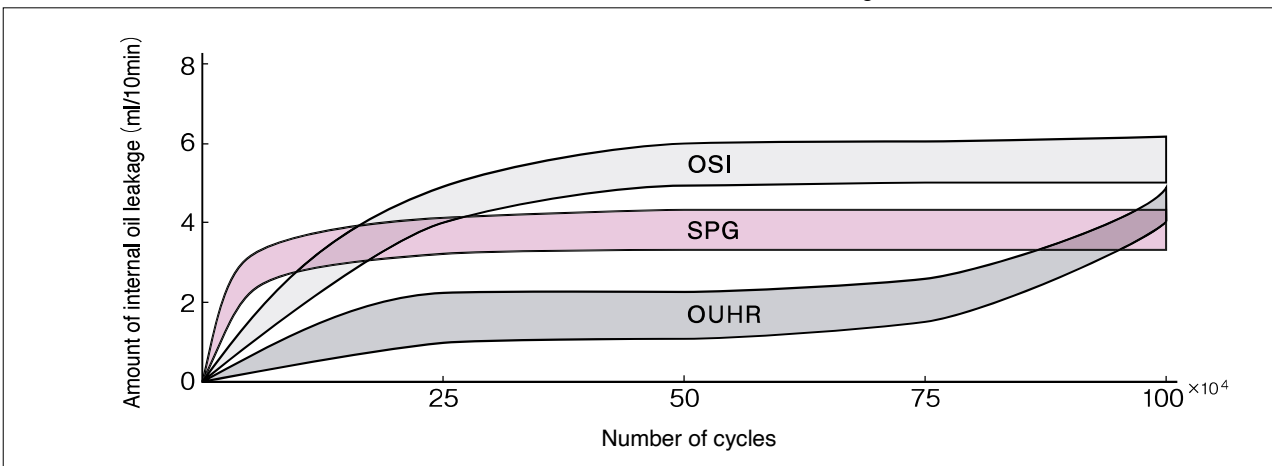

〈Fig. H-17〉 Change in amount of internal oil leakage

Type & size	Direction of photo	Surface condition	Remarks
SPG 94 110 7.3	<p>Head side Rod side</p>		No abnormalities are observed on the sliding face.
OSI 110 95 9	<p>Head side</p>		Wear and "sliding trace" are observed on the sliding face.
	<p>Rod side</p>		
OUHR 110 95 9	<p>Head side</p>		Wear and "heavy sliding trace" are observed on the sliding face.
	<p>Rod side</p>		

〈Fig. H-18〉 Sliding surface condition after test

- For extremely short stroke, it is recommended to use combination seal (SPG or SPGW), using NOK Rareflon as the sliding material.

ROD PACKINGS

Fig. H-19 shows the condition of sliding surface after the extremely short stroke test.

Type & size (Material)	Direction of photo	Surface condition	
		When buffer ring is used together.	When buffer ring is not used together.
〈Buffer ring〉 HBTS 75 90.5 5.9 (19YF, A626)			
〈Rod packing〉 IUH 75 85 6 (A505)			

〈Fig. H-19〉 Condition of sliding surface after test

- It is recommended to use the buffer ring (HBTS or HBY) as a part of the sealing system along with the packings, when extremely short stroke condition is expected. Abnormal wear of rod packing may occur due to breakage of oil film without the buffer ring.

9. PHENOMENON OF BURNING

In some cases, piston packings or wear rings are burned and carbonized or melted. This is due to the high temperature resulting from sudden compression when air inside the hydraulic cylinder has not been completely exhausted.

For example, when a U packing is used as a piston packing, air tends to be accumulated in the pocket part of the U packing. When this air is not replaced by oil at starting movement, the air will be compressed quickly, resulting in high heat generation, at the U packing's pocket, as shown in Fig. H-20.

The packing may result in partially burned and carbonized. Some material may actually melt.

When the rod is directed upward, air is accumulated at the pocket part of U packing A on the head side, and "damage by burning" can be seen in Fig. H-21. Also, the wear ring may be burnt, as shown in Fig. H-22.

The phenomenon of burning tends to occur when starting a hydraulic cylinder, but seldom occurs during operation.

The heat generation due to adiabatic compression may reach 600 to 800°C for a short period of time and instantaneously exceeds the heat resistant limit of packing material.

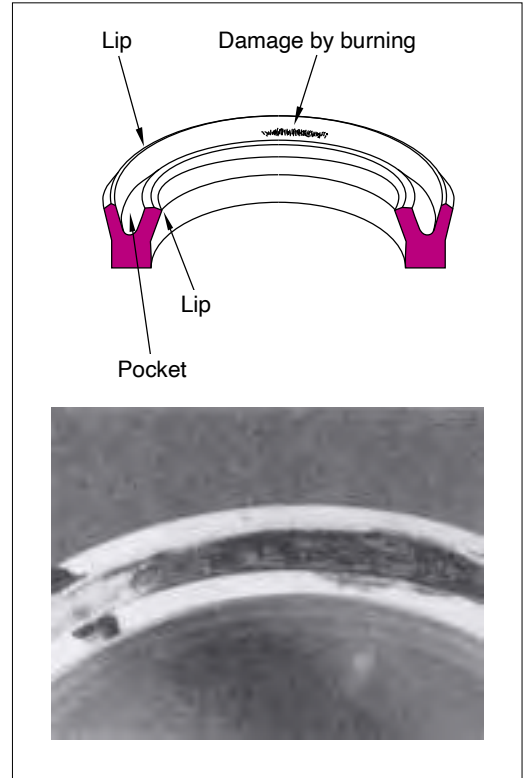

<Fig. H-20> Example of damage by burning of U packing

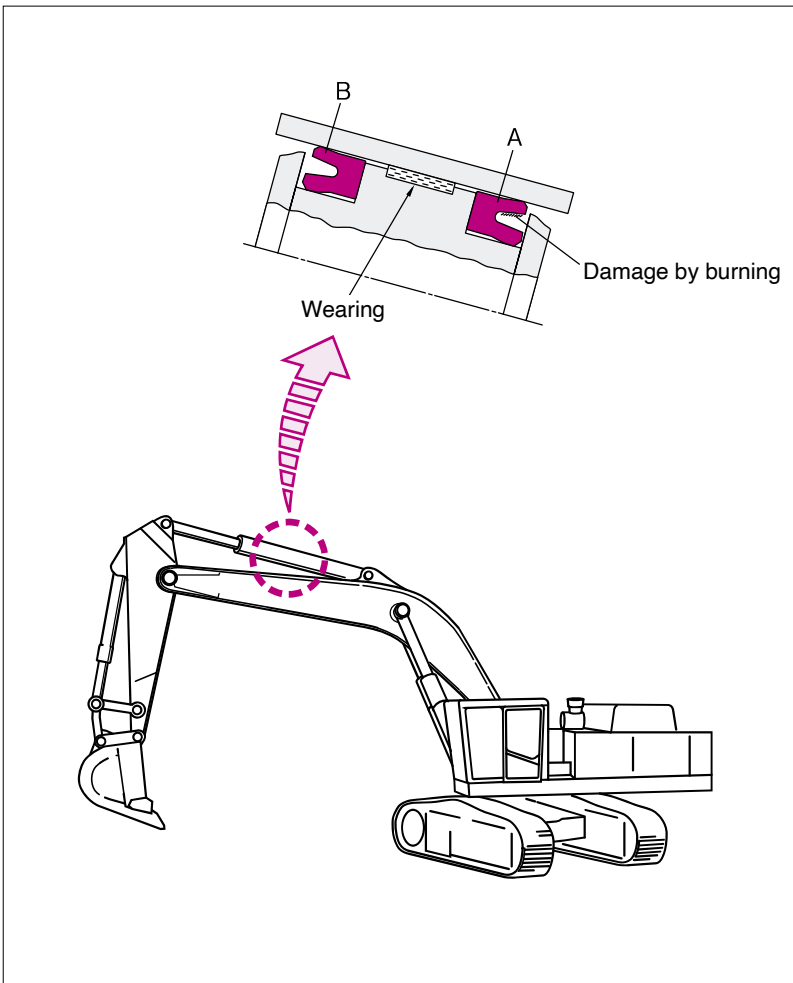

<Fig. H-21> Example of locations of damage by burning

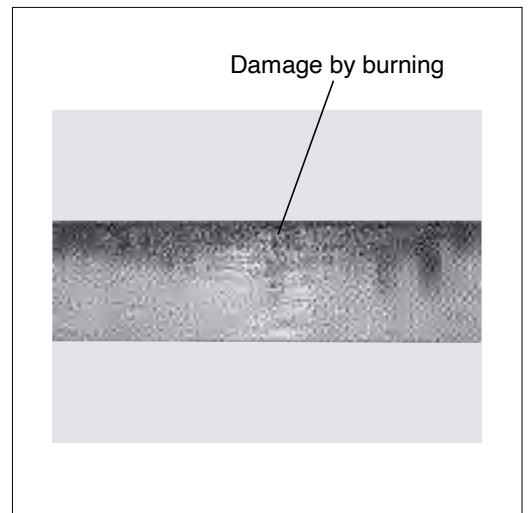

<Fig. H-22> Example of damage by burning of wearing

■ FORMULA FOR CALCULATING RISE OF TEMPERATURE BY ADIABATIC COMPRESSION

Although, in the case of an actual hydraulic cylinder, it cannot be said to be a perfect adiabatic compression due to the existence of heat conduction and dispersion, etc. from the rod surface or tube wall face, the rise of temperature can be calculated from the formula (7).

$$T_2 = T_1 \times \frac{P_2 \cdot V_2}{P_1 \cdot V_1} = T_1 \left(\frac{P_2}{P_1} \right)^{\frac{\kappa-1}{\kappa}} \dots\dots\dots (7)$$

- T₁ : Absolute temperature before compression (°K)
- T₂ : Absolute temperature after compression (°K)
- P₁ : Pressure before compression (MPa)
- P₂ : Pressure after compression (MPa)
- V₁ : Volume of air before compression (cm³)
- V₂ : Volume of air after compression (cm³)
- κ : Adiabatic index (In case of air, κ = 1.4)

Now, let's calculate the heat generation by adiabatic compression by using this formula. Suppose the pressure in the hydraulic cylinder varies between 1 and 42MPa. For example, suppose the oil temperature is 80°C when the pressure is 1MPa, then the absolute temperature T₂ by the adiabatic compression is

$$T_2 = (273 + 80) \times \left(\frac{42}{1} \right)^{\frac{1.4-1}{1.4}} \doteq 1027 (°K)$$

This temperature is equivalent to 754°C. The value neglects the adiabatic efficiency and other loss in its calculation. Even if this were taken into consideration, the packing is instantaneously exposed to a high temperature.

■ PREVENTION OF DAMAGE BY BURNING

Remark the following points to prevent the damage of burning due to such adiabatic compression.

- (1) Bleed air from the hydraulic cylinder sufficiently before starting the hydraulic cylinder.
- (2) When starting the hydraulic cylinder, do not operate it quickly to its full stroke.
- (3) When using U packings, fill the pocket with grease to minimize the accumulation of air.
- (4) Design the construction of piston as shown in the **Fig. H-23** and use Rareflon seal (Type KZT, contamination seal) having a good heat resistance at the outside of the wearing (WR).

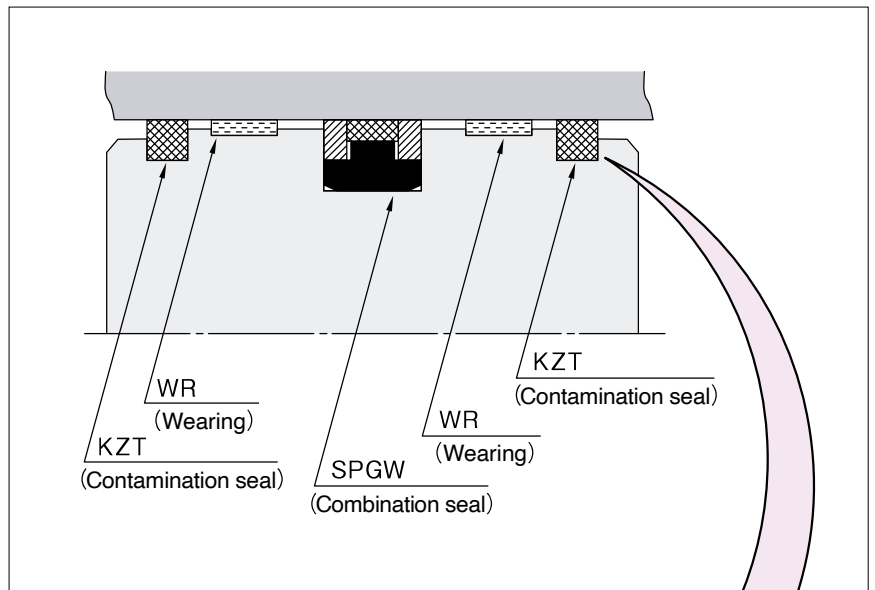

〈Fig. H-23〉 Example of countermeasure against damage by burning

TECHNICAL DATA

● **Fig. H-23** shows the most effective piston sealing system as a countermeasure against the damage by burning.

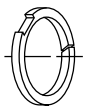

We recommend to use KZT (Contamination seal) to prevent entry of foreign materials in the oil and to prevent the damage by burning.

10. STICK-SLIP

■ PHENOMENON

Stick-slip is a phenomenon that a sliding surface has sticking and slipping condition periodically. In the case of packings, the stick-slip occurs at a contact face between a packing, an elastic body, and metal mating face, sometimes resulting in vibration and generating sound.

The stick-slip phenomenon in hydraulic cylinders is caused by complex factors including types of bearings, types of packings, fixing method of cylinder, amount of load, etc. Also, the sound generated by stick-slip varies from low to high frequency tones.

■ CONDITIONS CAUSE THE PHENOMENON

Vibrations and sound generation due to the stick-slip of a hydraulic cylinder have not been quantitatively clarified yet. It is qualitatively known, however, that they occur under the following conditions.

- (1) When a static friction coefficient of a packing or bearing material is high.
- (2) When the roughness of metallic surface is not appropriate.
- (3) When the quality of oil used is poor (when the additive to oil is not appropriate).
- (4) When the lubricant film on the sliding face is liable to be broken due to a high pressure, high temperature or operation in a low speed.
- (5) When using a cylinder tube or a hollow rod which thickness is extremely thin or when using a hydraulic hose with a low rigidity.

■ COUNTERMEASURES

As previously mentioned, it is not possible to make perfect countermeasures for stick-slip solely by a packing itself. However, use of a combination seal (SPG or SPGW) made from low-friction material such as Rareflon or use of the U packing (OUHR) improved self lubrication.

Also, additional use of a buffer ring with good lubricating characteristic (HBTS) as shown in **Fig. H-24(a)** and/or filling grease between a rod packing and a dust seal will be effective in preventing oil film breakage, due to high pressure.

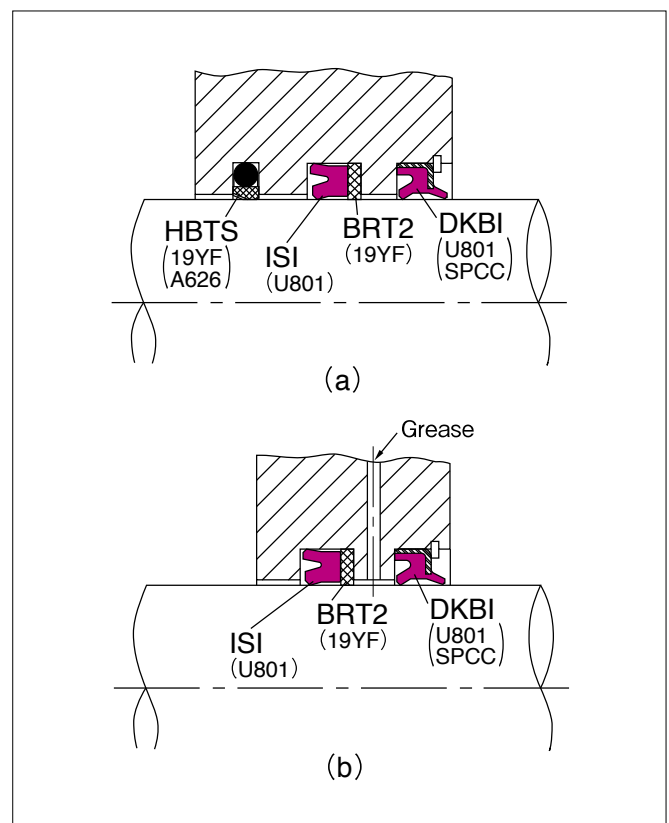

(Fig. H-24) Example of countermeasure against stick-slip

11. BREAKAGE DUE TO PRESSURE BUILD-UP

When two lip packings are used back-to-back for the piston, the packings fail due to pressure build-up between them. The failure occurs because the oil film passing through the packings remains between the packings due to reciprocal movement, gradually increasing the pressure (Fig. H-25). Also, when using multiple packings, it is necessary to consider the possibility of pressure build-up. Using a packing with a notch (relief passage) at the tip of the lip is an effective countermeasure to pressure build-up. If there is no notch, the lip end surface and installed groove surface side touch each other due to back pressure, so pressure in the U-groove is not released, forcing the sliding-side lip into close contact with the sliding surface. As a result, because back pressure is not released, the packing is pressed to the pressure-side

groove surface side, breaking the lip starting from the point touching the corner of the groove. However, when a notch is provided, since the pressure in the U-groove is released via the notch, the sliding-side lip easily collapses at back-pressure actuation, relieving the back pressure. For reference, Fig. H-26 shows the difference in back-pressure relief performance when a notch is and is not provided.

※ For rod packings, it is also necessary to consider pressure build-up when using multiple packings. For example, pressure build-up may occur when using a double-lip dust seal and a rod seal together. The most reliable countermeasure to pressure build-up is a drain between the packings (returning oil to oil tank). Using a DKBI3 dust seal with small holes on the oil lip allows pressure build-up oil to escape

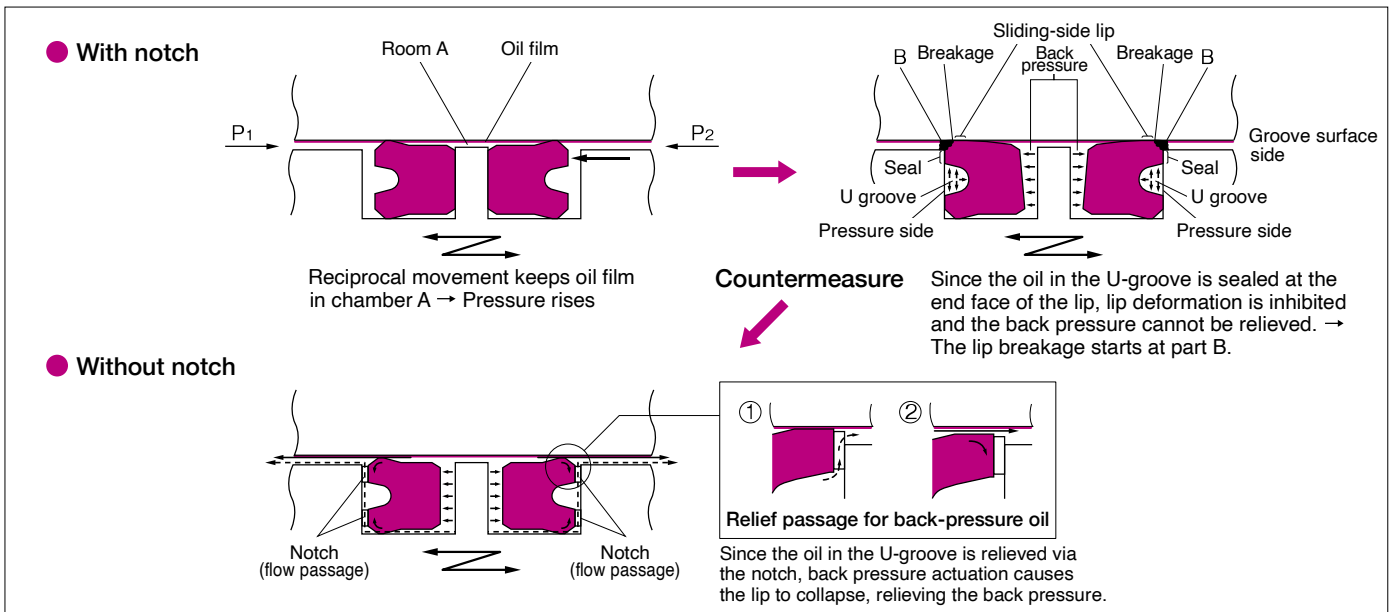

〈Fig. H-25〉 Mechanism of package failure due to pressure build-up and countermeasures

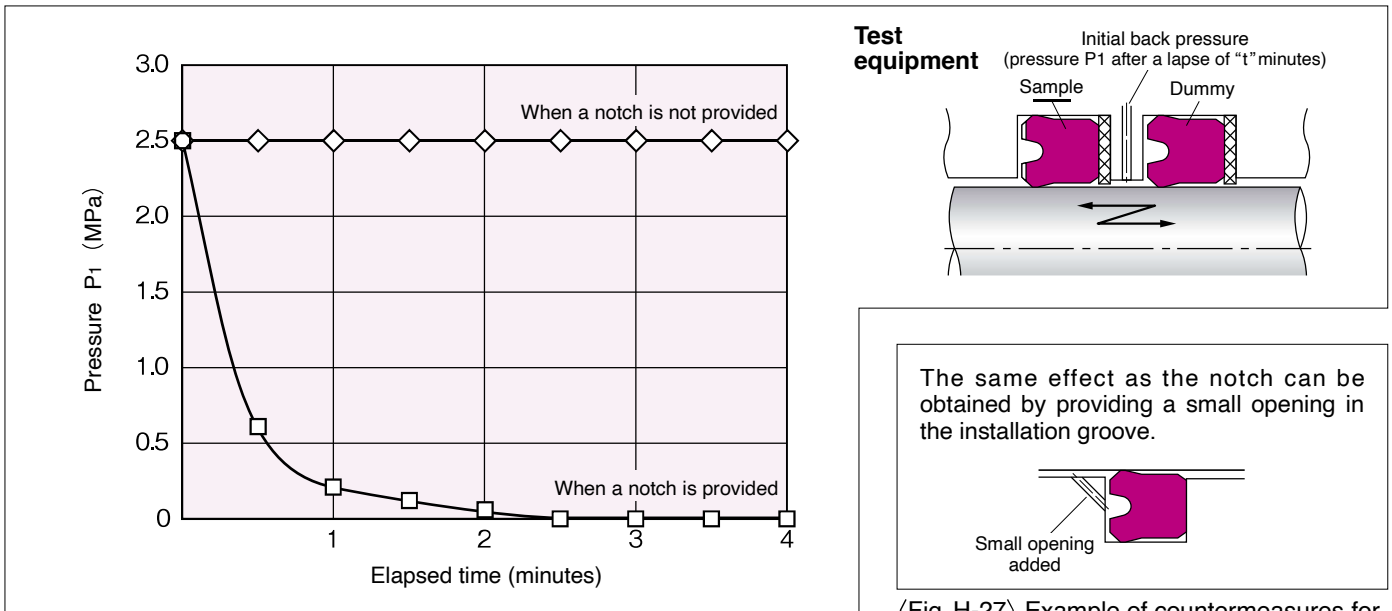

〈Fig. H-26〉 Back pressure leakage performance is different with and without a notch.

〈Fig. H-27〉 Example of countermeasures for pressure build-up without packing

12. BLOW-THROUGH LEAKAGE (PASSING)

A packing initially seals oil under its own compression force. After application of pressure, it also seals high oil pressure by further extension due to oil pressure. Therefore, for the packing to maintain its sealing performance, it is important to introduce the oil pressure into the installation groove and to obtain the extension force due to oil pressure. Blow-through leakage (passing) occurs infrequently when the oil pressure is not introduced smoothly into the installation groove in the above state.

Once blow-through leakage has occurred, a great amount of leakage may continue for a long time, yet at the same time, blow-through leakage does not always reoccur when investigating the cause. This makes blow-through leakage a very troublesome phenomenon. Such leakage typically occurs when pressure acts in both directions of the combination seal for a piston packing on a power steering cylinder. For example, as

shown in Fig. H-28, blow-through leakage occurs when the positive pressure acts from the left and back pressure acts from the right. Since the packing is pressed into the left-hand groove side by the back pressure, it is difficult for positive pressure from the left to enter the groove. As a result, extension force due to oil pressure is not obtained, causing blow-through leakage. A countermeasure for blow-through leakage is to smooth the introduction of oil pressure into the installation groove by installing "an oil pressure introduction slit" in the side of the seal ring.

Also, blow-through leakage tends to occur when the pressure causes extrusion of the seal ring or lowers the interference. A slit is effective in these cases and the packing becomes more reliable and has prolonged life.

※ A combination seal with a slit is a special product and is not described in this catalog; consult NOK for details.

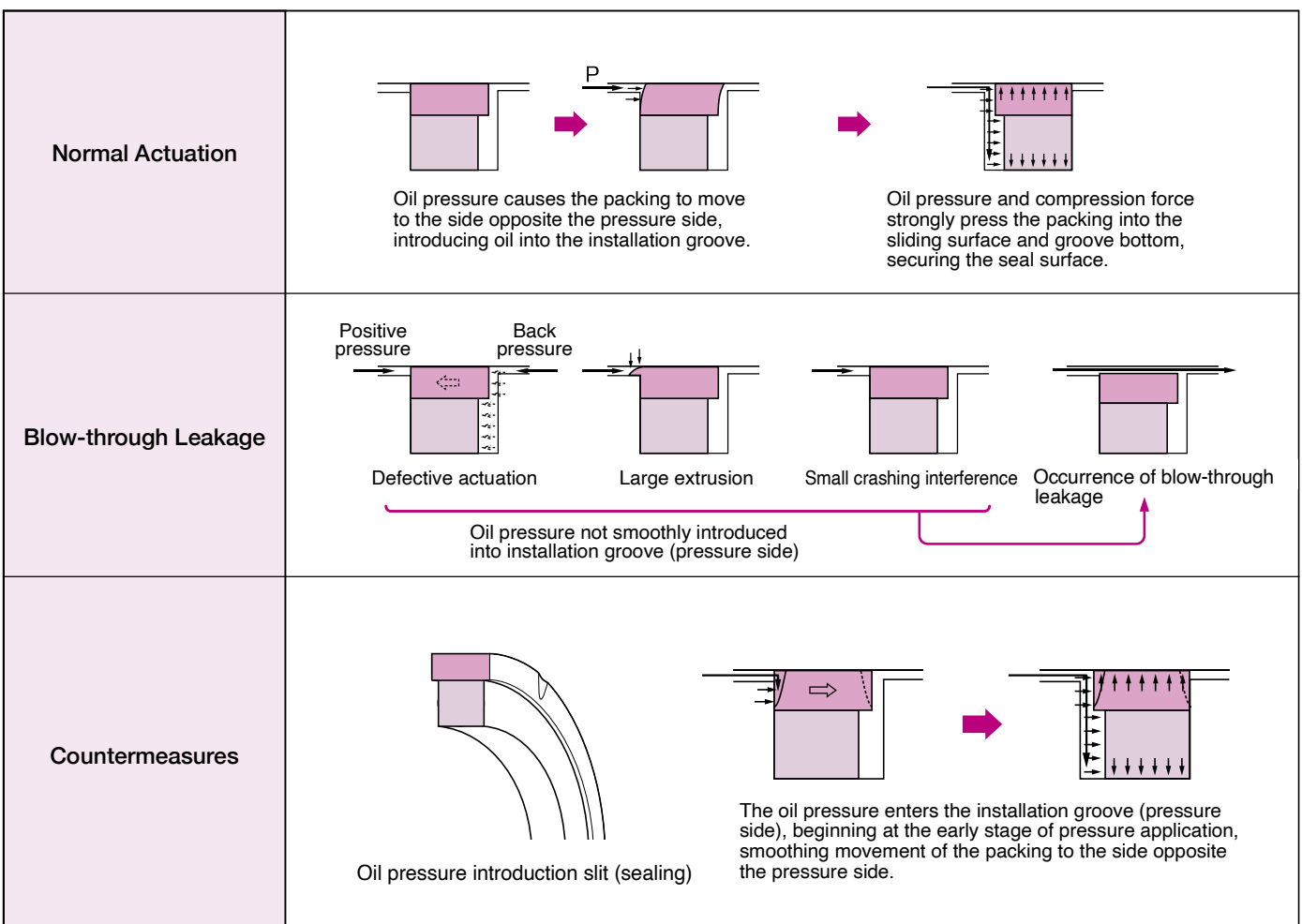

〈Fig. H-28〉 Blow-through leakage in combination seals and countermeasures for blow-through leakage

13. SWELLING MECHANISM

Swelling is the state in which equilibrium is attained between the force of oil molecules entering the polymer molecules and spreading the spacing between polymer molecules and the elasticity of the cross-linked meshes.

Whether the swelling is large or small depends

directly on the affinity between the oil and polymer, the larger the affinity, the larger the swelling.

The SP (Solubility Parameter) value is often used as an index of affinity. Two materials with similar molecular structures have larger affinity (the closer the polarity, the larger the affinity).

〈Example 1〉 EPDM and mineral oil (high affinity) → Large swelling

EPDM SP value: 8 (small polarity)	Mineral oil SP value: 6 to 8 (small polarity)
$[\text{CH}_2 - \text{CH}_2]_n [\text{CH} - \text{CH}_2]_m$ $\quad \quad \quad $ $\quad \quad \quad \text{CH}_3$	$\text{C}_n\text{H}_{2n+2}$

→ EPDM and mineral oil are similar in structure (only C and H have no polar group) and their affinity is high, so the swelling is large.

〈Example 2〉 NBR and mineral oil (poor affinity) → Small swelling

NBR SP value: 9 to 10 (large polarity)	Mineral oil SP value: 6 to 8 (large polarity)
$[\text{CH}_2 - \text{CH} = \text{CH} - \text{CH}_2]_n [\text{CH} - \text{CH}_2]_m$ $\quad \quad \quad $ $\quad \quad \quad \text{C} \equiv \text{N} \leftarrow \text{Polar group}$	$\text{C}_n\text{H}_{2n+2}$

→ NBR and mineral oil are dissimilar (NBR has a polar group) and their affinity is poor, so the swelling is small.

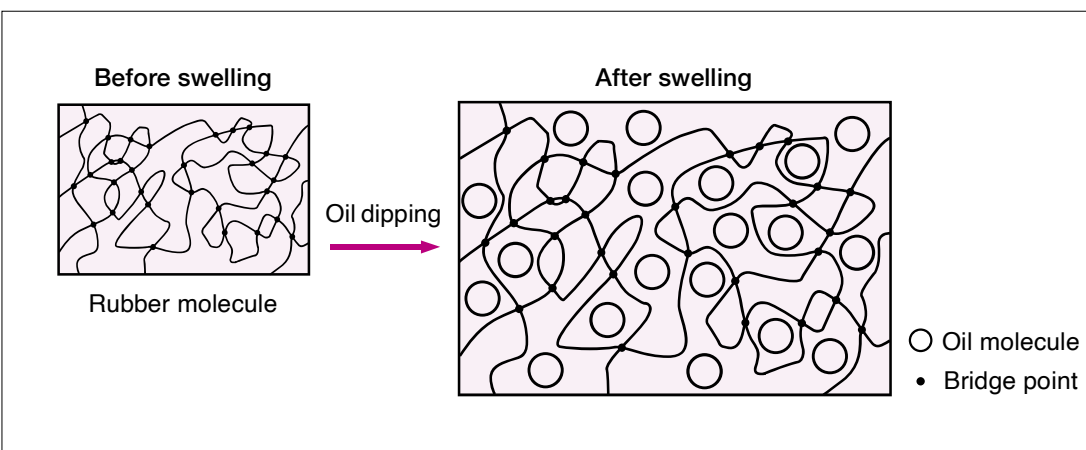

〈Fig. H-29〉 Swelling advancement

Oil tries to get between rubber molecules, spreading the clearance between the rubber molecules (swelling phenomenon).

The clearance between the rubber molecules is spread by oil swelling, but because of bridges, clearance swelling does not occur beyond a point (called equilibrium swelling).

< Reference: With non-bridged rubbers, swelling becomes bigger and bigger until dissolution finally occurs (such as rubber adhesive material and spray glue). >

14. ROUGHNESS OF CONTACTING OBJECT

■ Roughness of Sliding Surface

Surface roughness greatly affects seal performance, efficiency and life, and both the size and form of the roughness are very important. When a surface has convexities, the seal wears quickly.

Conversely, seal durability is improved when a surface has concavities that form oil reservoirs, reducing seal abrasion.

For this reason, we recommend using a roller vanishing finish (RLB) for the inside surface of the cylinder tube and a buff finish (SPBF) for the rod surface to flatten convexities.

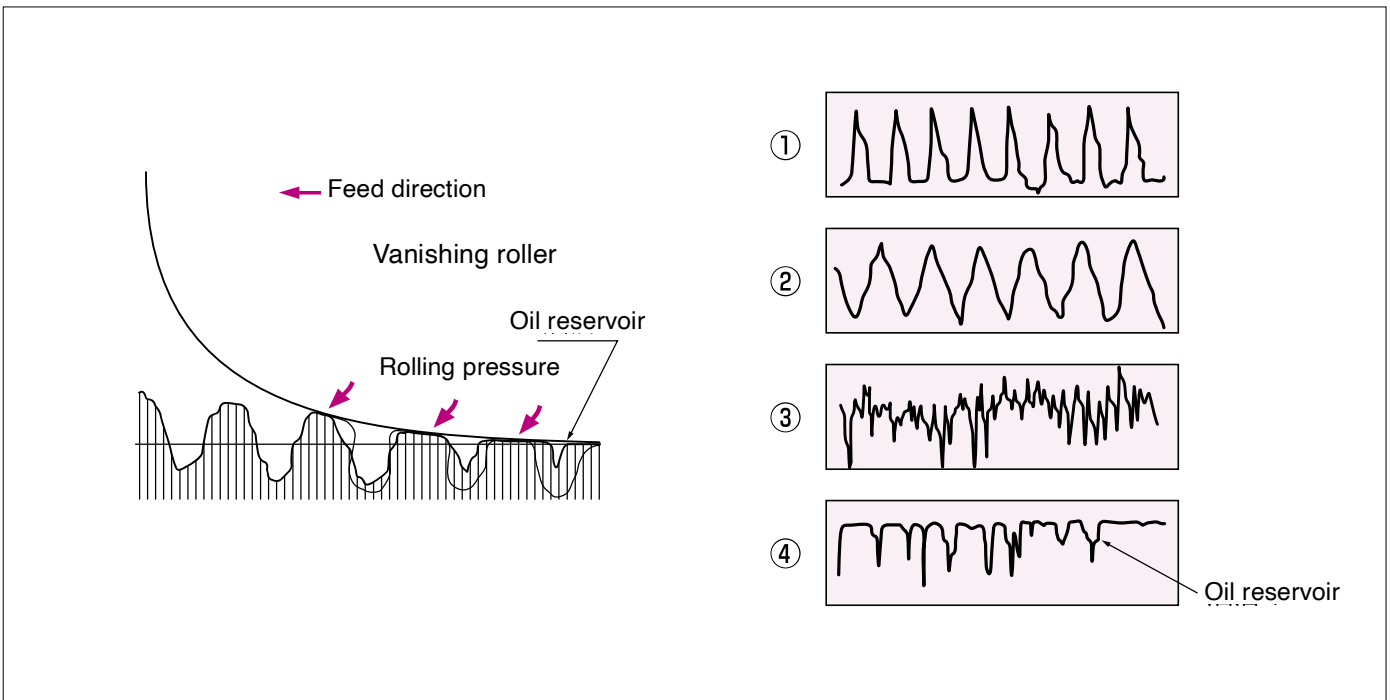

〈Fig. H-30〉 Roughness example

①~④ are examples of surface roughness.

④ is the figure of roughness when the roller vanishing finish is used.

Using the roller vanishing finish, convexities are flattened by plastic deformation, and an oil reservoir is formed in concavities, reducing the seal's abrasion and improving its durability.

■ Roughness of Groove Bottom

Generally, the packing installation groove is machined by a lathe, so it has a spiral continuous machining track (roughness), but since the packing material has flexibility, the machining track does not become an oil relief passage due to filling-in of concavities in the rough area. However, when the roughness is large, concavities in the rough area cannot be filled in, forming an oil relief passage and causing oil leakage. The sliding surface of the packing is often managed because of packing friction problems. When the roughness of the bottom of the installation groove cannot be reduced

sufficiently due to high machining difficulties, oil leakage may occur. The permissible roughness of the bottom of the groove is 6.3 mmRz or smaller for rubbers, such as nitrile rubber, with high flexibility, and 3.2 mmRz or smaller for iron rubber with relatively high rigidity. However, since the ability to match the roughness of the contact object is affected by both the rubber material and the pressing force (compression force), the ability may differ due to the shape of the packing even when the material is the same.

※ The roughness index is based on JIS B 0601: 2001.

15. SEALING SYSTEM (COMBINATION EFFECT)

Example of Long-life System for Construction Machines

Among hydraulic cylinders, the cylinders of construction machines are subject to harsh usage conditions, such as high pressure and temperature.

Since the sealing system is used outdoors, external contamination is severe and the sealing system must cope with harsh use. The traditional mainstream rod sealing system used a combination of buffer rings, rod seals and dust seals made of high-strength iron rubber.

However, recently, nitrile rubber is increasingly being used as the rod packing material to improve performance and prolong life.

Compared to iron rubber, nitrile rubber has excellent ability to follow low-temperature eccentricity, so increasing use of nitrile rubber for rod seals improves low-temperature sealing performance and low-temperature durability.

However, use of nitrile rubber assumes use of a buffer ring with the rod packing, because the strength of nitrile rubber is lower than iron rubber (Fig. H-31, Fig. H-32).

As shown in this example, to achieve excellent long-term seal performance, it is necessary to examine not only the selection of each packing, but also the system configuration.

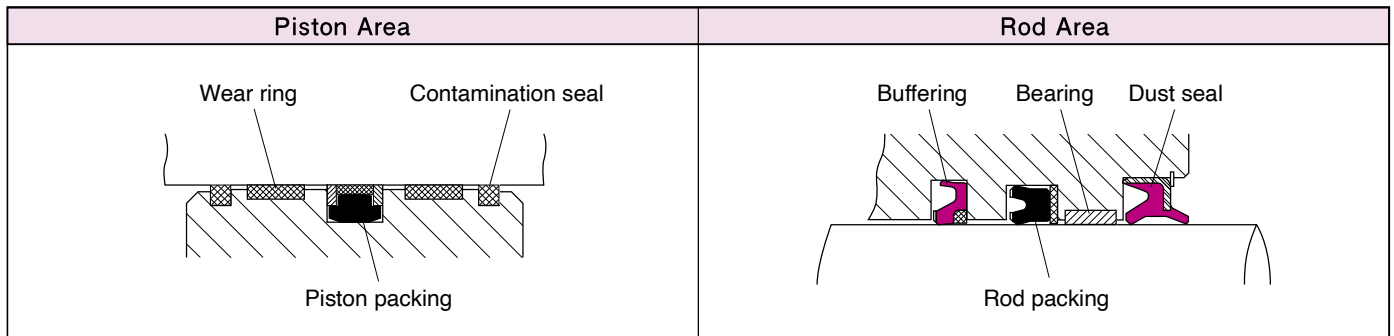

(Fig. H-31) Example of sealing system for hydraulic cylinder of a construction machine

	Shape	Material	Main function	Feature
Piston Area	 Piston packing	① PTFE : Rareflon ② PA : Polyamide ③ NBR : nitrile rubber	Retention of oil pressure	A PTFE seal ring ① with excellent friction and abrasion characteristics is used. Also, to augment PTFE's creep characteristics and pressure resistance, a combination of a buffer ring ③ made of NBR and a backup ring ② made of PA is used.
	 Contamination seal	PTFE : Rareflon	Elimination of foreign objects in oil	Intrusion of foreign objects into the piston packing is inhibited by burying and capturing the foreign objects not only by scraping off foreign objects in the oil but also using PTFE's plastic deformability.
	 Wear ring	PTFE : Rareflon	Bearing	Stick-slip is prevented by using PTFE's excellent friction characteristics. Fabric phenol resin with high elasticity is used for applications requiring large lateral load.
Rod Area	 Buffering	① PUR : Iron rubber ② PA : Polyamide	Buffering of impact pressure applied to rod packing	Since there are high pressures, a PTFE seal ring ① is used in combination with a PA backup ring ②, to use PUR with a combination of strength and flexibility so that the pressure resistance is supplemented.
	 Rod packing	① NBR : nitrile rubber ② PTFE : Rareflon	Prevention of external oil leaks	Long life is achieved by using NBR with excellent creep characteristics. Supplementing pressure resistance using a PTFE backup ring ② with (② made of PA is inappropriate due to the large strength difference between ② and ① causing extrusion breakage in ①).
	 Dust seal	① PUR : Iron rubber ② SPCC	Prevention of intrusion of foreign objects	To cope with the harsh external contaminant conditions, high-strength PUR is used to resist plastic deformation.

(Fig. H-32) Features of each packing material

TECHNICAL DATA

16. BLISTERS

■ Phenomenon

Blisters refers to foam or bubbles formed in the vicinity of sliding sections of the seal when liquid absorbed into the seal is converted to gas form by sliding heat generation.

Since packing is used at high pressures, blisters in the vicinity of the sliding face of the seal can cause peeling due to friction caused by sliding movement in the vicinity (Fig. H-33).

■ Conditions conducive to blisters

Where volatile oils are used, blisters may form in a high-temperature operating environment (high temperature, high speed, high pressure). In some cases this is caused by the presence of a volatile foreign oil in the oil being used.

■ Response

Blisters are caused by certain combinations of oils and operating conditions. Although the problem cannot be solved by packing alone, it is possible to reduce sliding heat generation through the use of low-friction materials such as combined seals made from Rareflon and self-lubricating U-packing such as OUHR.

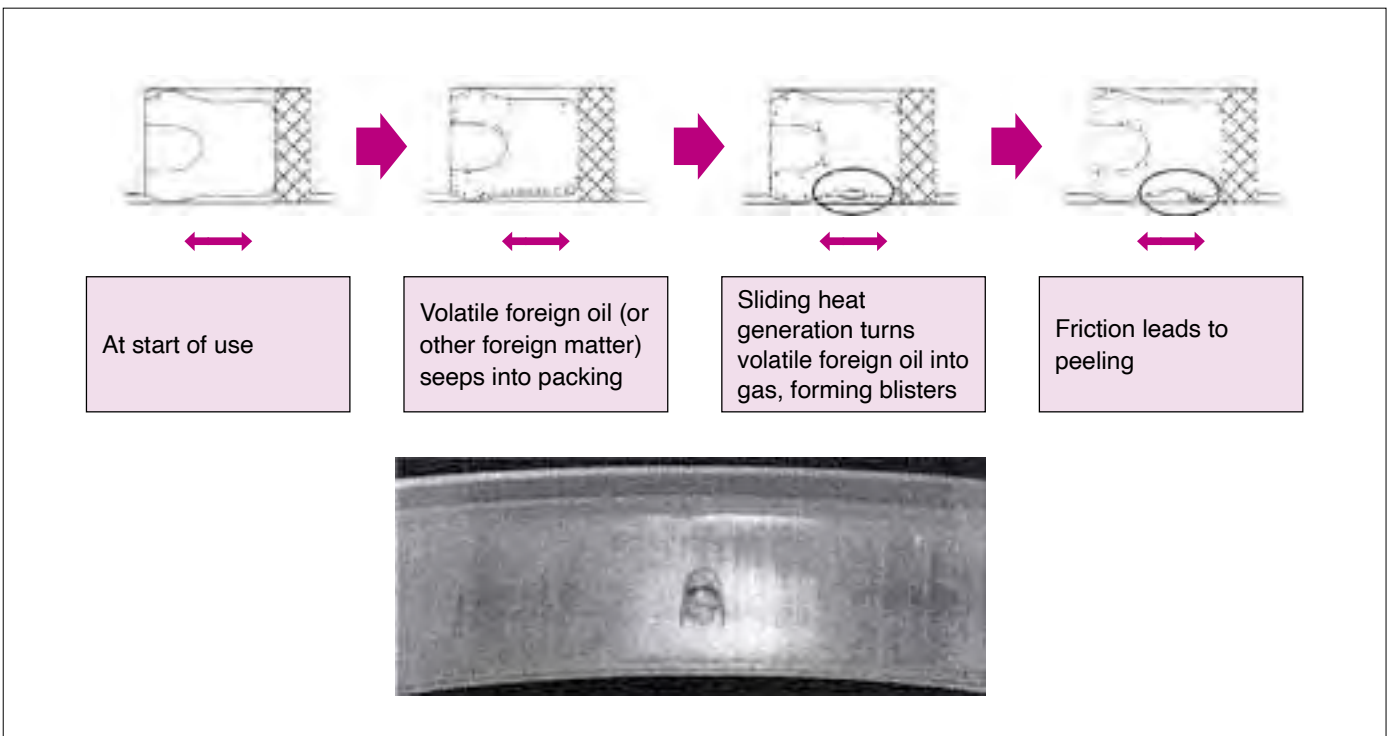

(Fig. H-33) Packing example (blister formation ⇒ peeling)



DATA FOR REFERENCE

OIL RESISTANCE AND CHEMICAL RESISTANCE OF NOK MATERIALS —	272 ~ 292
FITTING TOLERANCE FOR SHAFT —————	294
FITTING TOLERANCE FOR BORE —————	295
STANDARD FITTING TOLERANCE FOR LARGE DIAMETER ———	296
TABLE OF MAJOR SI UNIT CONVERSION —————	296
TABLE OF HARDNESS CONVERSION —————	297
RANGE OF ROUGHNESS BY VARIOUS METHODS OF PROCESSING —————	297
CHANGE OF SURFACE ROUGHNESS JIS STANDARD —	297
TABLE OF VISCOSITY CONVERSION —————	298
TABLE OF TEMPERATURE CONVERSION —————	299
NOK KLUEBER LUBRICANT FOR SEALS —————	300 ~ 301
LINE-UP OF NOK PRODUCTS —————	302 ~ 303

I. DATA FOR REFERENCE

■ OIL RESISTANCE AND CHEMICAL RESISTANCE OF NOK MATERIAL

This data is a summary of all the experimental data related to the materials and it gives a reference of material compatibility to each brand of oil or chemical. When selecting material, kindly check, referring to this collection of data, whether the material in question is compatible to the brand of oil or chemical which you are going to use. Please note, however, that they are representative values of actual measurement and not of guarantee.

This data includes nonstandard materials for each type of packing, due to the fact that the selection of material has been carried out in consideration of the sealing liquid in question.

When using materials other than standard, please consult with NOK.

[READING THE TABLES]

The test method is based on JIS K 6253, 6258 "Hardness method for vulcanized rubber and thermoplastic rubber, and dipping test method". The table shows the test temperature, time and change in hardness, tensile strength, volume after test, and compatibility.

+ symbol before figure means the increase to the value of before test, while - symbol means the decrease to the one of before test. In any case, if the absolute values of these figures are smaller, the better are oil and chemical resistances.

■ OIL RESISTANCE DATA

[NOK's material symbol] A : Nitrile rubber F : Fluoro rubber G : Hydrogenated-nitrile rubber
U : Iron rubber

(- : No data available)

Brand name of sealing liquid (Manufacturer)		NOK's material symbol	Test temperature (°C)	Duration of test (H)	Change in hardness (points)	Change in tensile strength (%)	Change in volume (%)	Adaptable or not
Diesel engine oil	DELPACK SHC 5W-30 (MOBIL)	A105	80	70	- 5	- 17	+ 4.6	○
				240	- 5	- 13	+ 5.4	
			120	70	- 4	- 25	+ 3.5	△
			240	- 2	- 45	+ 2.9		
		A305	80	70	- 5	- 14	+ 4.0	○
				240	- 6	- 16	+ 5.2	
			120	70	- 5	- 27	+ 4.0	△
			240	- 2	- 44	+ 3.2		
		A505	80	70	- 4	- 6	+ 3.3	○
				240	- 3	- 2	+ 4.0	
			120	70	- 3	- 15	+ 3.4	△
			240	- 1	- 28	+ 3.3		
		A980	80	70	- 9	- 10	+ 7.9	○
				240	- 8	- 16	+ 7.7	
			120	70	- 8	- 34	+ 9.0	×
	240	- 6	- 58	+ 9.0				
DELPACK 1210 (MOBIL)	U593	100	500	- 2	- 33	+ 5.5	○	
	U641	100	500	0	- 8	+ 5.2	○	
	U801	100	500	- 1	- 18	+ 4.8	○	
	U801	120	500	+ 1	- 44	+ 0.3	○	

Compatibility is the result from judgement supposing the case where the product has been continuously operated for 500 hours at the temperature specified in the Table. If data exceeding 500 hours are available, compatibility for the said duration is also mentioned. Symbols used in the column of compatibility are as follows:

- : Resistant
- : Resistant except special cases *
- △ : Not resistant except special cases *
- × : Not resistant

※ When using this, please consult with NOK

In most cases, judgement is made based upon the data of change in hardness and volume. In some cases, however, the judgements show △ or × in spite of the small value with hardness and volume. The "compatibility" is judged by taking other factors into account, so they are not contradictory to the principle mentioned above. The compatibility of IRON RUBBER is judged mainly by change in tensile strength.

On the other hand, the test conditions applicable to these data are defined to examine the compatibility of each rubber material with the sealing liquid and not to guarantee the life of the liquid in question. For nature of the liquid, refer to the handbook for brands of lubricants.

OIL RESISTANCE DATA

Brand name of sealing liquid (Manufacturer)		NOK's material symbol	Test temperature (°C)	Duration of test (H)	Change in hardness (points)	Change in tensile strength(%)	Change in volume (%)	Adaptable or not	
Diesel engine oil	MOBIL PEGASUS 10W (MOBIL)	U641	100	1000	- 1	- 24	+ 3.7	○	
		U801	100	500	- 2	- 17	+ 1.3	○	
				1000	0	- 73	+ 0.9	×	
	WHITE PARROT SUPER S-3 OIL 10W (SHOWA-SHELL)	A105		120	70	0	- 23	- 0.9	
					240	+ 1	- 35	- 1.5	
					500	+ 2	- 48	- 1.8	△
					1000	+ 5	- 73	- 2.6	×
		A305		120	70	- 3	- 16	- 0.1	
					240	- 2	- 38	- 0.9	
					500	0	- 49	- 1.4	△
					1000	+ 4	- 76	- 1.9	×
		A505	80		70	- 4	- 12	+ 2.3	
					240	- 4	0	+ 2.2	
					500	- 3	- 1	+ 2.3	○
					1000	- 2	- 5	+ 2.5	○
			100		70	- 3	- 3	+ 2.2	
					240	- 1	- 16	+ 1.4	
					500	0	- 27	+ 1.1	○
					1000	+ 2	- 41	+ 1.1	△
		120		70	+ 1	- 8	- 0.1		
				240	+ 1	- 7	- 0.3		
				500	+ 2	- 33	- 0.4	△	
				1000	+ 5	- 67	- 0.9	×	
		A980	120		100	- 4	- 1	+ 4.0	
					240	- 1	- 36	+ 4.0	
					500	+ 1	- 51	+ 3.6	×
					1000	+ 4	- 79	+ 3.1	×
	U641	120	500	+ 1	- 41	+ 2.3	○		
	U801	120	500	0	- 45	+ 0.4	○		
	G506	100		70	0	+ 1	+ 1.0		
				150	0	0	+ 1.3		
				300	+ 1	- 15	+ 1.6		
				500	+ 1	- 16	+ 1.6	○	
			1000	+ 3	- 18	+ 1.5	○		
		120		70	0	- 10	+ 1.2		
				150	0	- 10	+ 1.0		
			300	+ 2	- 14	+ 1.4			
	500		+ 2	- 18	+ 1.0	○			
	1000	+ 4	- 24	+ 0.7	○				
APPOLLOIL Diesel Motive S-310 (IDEMITSU)	A505	100	70	- 2	- 2	+ 1.6			
			150	- 1	- 8	+ 1.3			
			500	+ 1	- 5	+ 0.8	○		
			1000	+ 3	- 14	+ 0.7	○		
	120	70	- 2	0	+ 0.9				
		150	0	- 19	+ 0.7				
		500	+ 4	- 62	+ 0.5	×			
		1000	+ 7	- 74	- 0.3	×			
	A980	80	150	- 3	- 6	+ 2.7			
			500	- 2	- 13	+ 2.0	○		
			1000	- 1	- 19	+ 2.1	○		
			100	70	- 4	+ 3	+ 3.5		
		150		- 3	- 14	+ 3.2			
		500		0	- 29	+ 3.2	○		
		1000		+ 4	- 31	+ 2.5	△		
		120	70	- 4	- 4	+ 4.8			
	150		- 2	- 42	+ 4.5				
	500		+ 5	- 69	+ 2.9	×			
	1000		+ 8	- 78	+ 1.5	×			
	G869	100	70	+ 2	0	+ 1.8			
150			+ 1	0	+ 2.3				
500			+ 3	- 3	+ 2.5	○			
1000			+ 4	- 4	+ 2.4	○			

DATA FOR REFERENCE

OIL RESISTANCE DATA

Brand name of sealing liquid (Manufacturer)		NOK's material symbol	Test temperature (°C)	Duration of test (H)	Change in hardness (points)	Change in tensile strength(%)	Change in volume (%)	Adaptable or not
Diesel engine oil	APPOLLOIL Diesel Motive S-310 (IDEMITSU)	G869	120	70	+ 2	- 3	+ 2.3	○
				150	+ 3	- 5	+ 2.4	
				500	+ 5	- 10	+ 2.6	
				1000	+ 6	- 17	+ 2.0	
	G928	100	70	- 3	0	+ 3.4	○	
			150	- 3	0	+ 3.5		
			500	- 2	+ 1	+ 3.6		
			1000	0	+ 2	+ 3.5		
		120	70	- 2	+ 1	+ 3.8	○	
			150	- 2	+ 3	+ 3.5		
			500	+ 1	+ 3	+ 3.4		
			1000	+ 2	- 9	+ 3.1		
Gear oil	APPOLLOIL GEAR-MISSION 80W-90 (IDEMITSU)	F201	100	70	- 1	- 4	+ 1.0	○
			120	70	0	- 25	+ 1.2	○
			150	70	+ 5	- 38	+ 1.7	△
	APPOLLOIL GEAR LSD 80W-90 (IDEMITSU)	F201	100	70	- 1	- 1	+ 0.8	○
			120	70	0	- 20	+ 1.1	○
			150	70	+ 4	- 30	+ 1.7	○
	GEARLUB SP90 (NISSEKI)	U652	100	336	0	- 33	+ 1.5	○
			U801	70	1000	- 1	+ 4	+ 1.3
		100	200	0	- 49	+ 1.7	×	
	GELCO-OIL 6140 (SHOWA-SHELL)	F204	120	70	0	+ 4	+ 0.2	○
	GELCO-OIL No 1 [GL-3] (SHOWA-SHELL)	F204	120	70	0	- 12	+ 0.6	○
	NISSAN GEAR OIL MP-G SPECIAL (NISSAN MOTOR GENUINE OIL)	F201	100	70	- 3	- 16	+ 2.0	○
			120	70	- 3	- 43	+ 3.5	△
			150	70	0	- 45	+ 4.2	△
		F357	100	70	- 1	- 5	+ 2.0	○
			120	70	- 1	- 40	+ 3.6	△
			150	70	- 1	- 36	+ 4.5	△
	NISSAN GEAR OIL HYPOID SUPER 80W-90 (NISSAN MOTOR GENUINE OIL)	G506	120	70	- 1	- 4	+ 2.7	○
	MOLUB-ALLOY GEAR OIL 170W (Castrol)	A505	100	70	- 2	+ 4	+ 2.3	○
			500	- 3	+ 3	+ 3.0		
		A795	100	70	+ 3	- 3	- 2.7	○
			500	+ 6	- 3	- 3.3		
	U801	100	70	0	- 3	+ 0.2	○	
		500	0	- 70	+ 0.6	×		
A T F	DEXIRON ii (SHOWA-SHELL)	A505	100	70	- 3	+ 5	+ 2.2	○
		A903	100	70	0	+ 3	- 0.8	○
	PAN ATF AMENITI (NISSEKI)	F357	120	70	- 1	- 1	+ 0.5	○
			240	- 1	- 5	+ 1.0		
			500	- 1	- 8	+ 1.2		
		150	70	- 1	- 20	+ 1.2	○	
			240	- 1	- 34	+ 1.7		
			500	- 1	- 53	+ 1.8		
	MOBIL ATF220 (MOBILE)	A104	100	70	- 3	- 4	+ 1.0	○
			168	- 3	- 6	+ 0.8		
		A105	100	70	- 4	- 8	+ 3.0	○
			168	- 3	- 10	+ 2.3		
		A305	100	70	- 7	- 3	+ 4.2	○
			168	- 5	- 9	+ 3.4		
		A980	100	70	- 5	+ 4	+ 5.1	○
			168	- 5	+ 6	+ 5.0		
	CASTLE AUTOFLUID SPECIAL W (TOYOTA MOTORS GENUINE OIL)	A505	100	70	- 6	+ 7	+ 5.2	○
			168	- 5	+ 8	+ 4.2		
		A903	80	70	- 5	+ 1	+ 4.7	○
			168	- 5	- 1	+ 4.0		
		100	70	- 6	+ 7	+ 5.3	○	
			168	- 4	- 5	+ 4.9		
	CASTLE HYDRAULIC OIL 32 (TOYOTA MOTOR GENUINE OIL)	A505	100	70	- 2	+ 7	+ 0.4	○
			168	0	+ 10	- 0.3		
A903		80	70	0	+ 10	- 1.6	○	
		168	+ 1	+ 10	- 2.3			
U801		100	336	0	+ 6	0	○	

OIL RESISTANCE DATA

Brand name of sealing liquid (Manufacturer)		NOK's material symbol	Test temperature (°C)	Duration of test (H)	Change in hardness (points)	Change in tensile strength(%)	Change in volume (%)	Adaptable or not	
A T F	POWER FLUID (NISSEKI)	U593	80	72	0	+ 1.0	+ 0.5	○	
				140	0	+ 1.4	+ 0.7		
				280	0	+ 1.5	+ 0.9		
B r a k e o i l	TOYOTA GENUINE BRAKE FLUID 2500H (TOYOTA)	F357	150	70	- 28	- 76	+ 44.6	×	
				168	- 32	- 85	+ 45.9		
		G506	150	70	- 13	- 16	+ 24.4	△	
				168	- 13	- 19	+ 24.3		
		A305	120	70	- 21	- 44	+ 51.1	×	
				210	- 27	- 61	+ 56.4		
H y d r a u l i c o i l	DAFFNEY HYDRAULIC FLUID 32 (IDEMITSU)	A795	100	200	+ 8	- 4	- 5.4	○	
		F548	150	200	0	- 5	+ 0.9	○	
	DAFFNEY HYDRAULIC FLUID 44 (IDEMITSU)	A505	100	70	+ 1	+ 8	- 0.9	○	
		HIGH LAND 26 (NISSEKI)	A505	100	70	- 6	+ 4	+ 5.4	○
	A903		100	70	- 3	- 5	+ 3.0	○	
	HYDRAX 56 (KYOSEKI)	A104	120	70	+ 4	+ 4	- 3.9	○	
		A105	120	70	0	- 13	- 0.7	○	
		A305	120	70	0	- 2	- 0.7	○	
		A505	120	70	0	- 12	- 0.9	○	
		A626	120	70	+ 1	+ 1	- 1.4	○	
		A980	120	70	- 2	- 14	+ 2.2	○	
		DIAMOND LUB RO32 (MITSUBISHI PETROL)	A505	100	70	+ 1	+ 10	- 0.3	○
			U641	100	1000	+ 1	+ 2	+ 0.2	○
	U801		100	1000	0	- 33	+ 1.3	○	
	TERASSE OIL C10 (SHOWA-SHELL)	A795	100	200	+ 4	- 3	- 1.8	○	
		F548	150	200	- 1	- 15	+ 2.7	○	
		U801	100	200	- 1	+ 2	+ 2.6	○	
	MITSUI HITEC 150 (MITSUI PETROL)	A505	100	240	- 1	+ 2	- 0.5	○	
				500	+ 1	+ 8	- 0.5		
				1000	+ 3	+ 8	- 0.4		
		A980	100	240	+ 1	+ 6	- 1.6	○	
				500	+ 3	+ 6	- 1.8		
				1000	+ 5	0	- 2.3		
		U593	100	1000	+ 1	+ 2	+ 0.8	○	
		U641	100	1000	0	- 15	+ 1.9	○	
		U801	100	1000	0	0	- 0.1	○	
		W e a r r e s i s t a n t h y d r a u l i c o i l	DAFFNEY SUPER HYDRAULIC FLUID 32 (IDEMITSU)	U593	100	168	+ 1	+ 7	+ 0.8
	U801			100	168	+ 1	- 5	- 0.7	○
	DAFFNEY SUPER HYDRO 32 (IDEMITSU)		U801	100	600	0	+ 10	+ 0.5	○
	DAFFNEY SUPER HYDRAULIC FLUID 46 (IDEMITSU)		G506	100	1000	+ 6	- 11	- 0.9	○
120					500	+ 5	- 15	- 0.8	
A305			100	166	- 2	- 5	- 2.2	○	
A626			100	166	+ 1	- 1	- 6.3	○	
A903			100	166	+ 6	- 10	- 6.5	○	
A980			100	166	+ 2	- 7	- 2.2	○	
DAFFNEY SUPER HYDRO 46 (IDEMITSU)	A505		100	70	- 2	+ 3	+ 0.5	○	
				150	0	- 4	+ 0.3		
				500	+ 2	+ 3	+ 0.2		
				1000	+ 4	+ 11	+ 0.5		
	120		70	150	- 1	- 7	+ 0.2	○	
					150	+ 1	- 3		- 0.1
		500			+ 6	- 15	+ 0.1		
		1000			+ 9	- 22	- 0.6		
		1000			+ 9	- 22	- 0.6		
	A567	80	70	70	+ 4	- 4	- 5.5	○	
				150	+ 4	- 3	- 5.5		
				300	+ 5	- 3	- 5.9		
				500	+ 5	- 7	- 6.4		
100	70	150	+ 4	- 5	- 5.3	○			
			150	+ 5	- 7		- 5.3		
			300	+ 6	- 7		- 6.2		
			500	+ 8	- 7		- 6.8		
			500	+ 8	- 7		- 6.8		
A980	100	70	- 1	- 7	- 1.2	○			
			150	+ 1	- 6		- 1.4		
			500	+ 4	- 9		- 2.2		
			1000	+ 7	- 6		- 2.4		

DATA FOR REFERENCE

OIL RESISTANCE DATA

Brand name of sealing liquid (Manufacturer)		NOK's material symbol	Test temperature (°C)	Duration of test (H)	Change in hardness (points)	Change in tensile strength (%)	Change in volume (%)	Adaptable or not
Wear resistant hydraulic oil	DAFFNEY SUPER HYDRO 46 (IDEMITSU)	A980	120	70	0	- 7	- 0.2	
				150	+ 2	- 13	- 1.0	
				500	+ 9	- 7	- 2.6	△
				1000	+ 12	+ 12	- 1.6	×
		G869	100	70	+ 2	+ 2	+ 0.2	
				150	+ 2	+ 3	+ 0.8	
				500	+ 3	+ 2	+ 0.9	○
				1000	+ 3	+ 3	+ 1.0	○
			120	70	+ 2	+ 4	+ 0.7	
				150	+ 2	+ 6	+ 1.0	
				500	+ 4	+ 4	+ 1.2	○
				1000	+ 5	- 1	+ 1.4	○
	G928	100	70	- 2	0	+ 2.6		
			150	- 2	0	+ 2.9		
			500	- 2	0	+ 2.8	○	
			1000	- 1	- 5	+ 3.2	○	
		120	70	- 2	- 3	+ 3.0		
			150	- 2	- 1	+ 3.2		
			500	0	- 2	+ 3.0	○	
			1000	+ 1	- 6	+ 2.8	○	
	U593	100	500	0	- 2	+ 1.0	○	
	U641	100	70	- 1	- 4	+ 1.7		
			300	- 1	+ 4	+ 1.6		
			560	- 1	+ 10	+ 1.7	○	
			1000	- 1	+ 9	+ 1.5	○	
			1500	- 1	+ 12	+ 1.9	○	
			2000	- 1	+ 11	+ 2.3	○	
	U801	100	70	- 1	- 4	+ 0.5		
			300	- 1	+ 18	- 0.2		
			560	- 1	+ 15	- 0.2	○	
			1000	- 1	+ 32	- 0.4	○	
			1500	- 1	+ 17	0.0	○	
2000			- 1	+ 26	+ 0.4	○		
DAFFNEY SUPER HYDRAULIC FLUID 56 (IDEMITSU)	A104	100	70	+ 1	+ 5	- 4.4	○	
			70	0	- 12	- 1.0	○	
			70	- 2	- 3	- 1.7	○	
			70	- 1	- 5	- 0.8	○	
			70	0	+ 4	- 4.3	○	
			70	+ 3	+ 3	- 2.2		
DAFFNEY SUPER HYDRAULIC FLUID 100 (IDEMITSU)	G506	100	1000	+ 7	- 4	- 2.8	○	
			500	+ 5	- 8	- 2.8	○	
DAFFNEY SUPER HYDRO A32 (IDEMITSU)	A305	100	70	- 3	+ 1	+ 1.0		
			168	- 2	+ 2	+ 0.4		
			500	+ 2	- 8	- 0.6	○	
			1000	+ 3	- 2	- 0.6	○	
	G506	120	70	0	+ 7	+ 0.1		
			168	+ 1	+ 4	+ 0.1		
			500	+ 2	+ 2	+ 0.2	○	
			1000	+ 3	+ 3	+ 0.4	○	
	G869	120	70	+ 2	+ 10	- 1.0		
			168	+ 2	+ 8	- 0.9		
			500	+ 4	+ 4	- 1.0	○	
			1000	+ 5	+ 2	- 0.7	○	
U801	80	70	0	+ 12	+ 0.5			
		240	- 1	+ 1	+ 0.6			
		500	- 2	0	+ 0.7	○		
		1000	- 2	- 3	+ 0.8	○		
		2000	- 2	- 7	+ 1.0	○		
		3000	- 2	- 19	+ 1.1	○		
		5000	- 3	- 47	+ 1.3	○		
		7000	- 5	- 76	+ 1.6	×		

OIL RESISTANCE DATA

Brand name of sealing liquid (Manufacturer)	NOK's material symbol	Test temperature (°C)	Duration of test (H)	Change in hardness (points)	Change in tensile strength(%)	Change in volume (%)	Adaptable or not	
Wear resistant hydraulic oil	DAFFNEY SUPER HYDRO A32 (IDEMITSU)	100	70	- 1	+ 8	+ 0.6		
			240	- 1	+ 6	+ 0.7		
			500	- 2	- 3	+ 0.8	⊙	
			1000	- 3	- 4	+ 0.9	⊙	
			2000	- 3	- 54	+ 1.2	△	
			3000	- 3	- 68	+ 1.2	×	
			7000	- 3	- 68	+ 1.2	×	
		120	70	- 1	+ 2	+ 0.3		
			240	- 1	+ 1	+ 0.4		
			500	- 2	- 31	+ 0.6	○	
			1000	- 3	- 75	+ 0.7	×	
			70	0	- 2	+ 1.8		
			240	- 1	- 9	+ 2.5		
			500	- 1	+ 2	+ 3.0	⊙	
	U641	80	1000	- 2	- 14	+ 3.3	⊙	
			2000	- 2	- 16	+ 3.6	⊙	
			3000	- 3	- 16	+ 3.7	⊙	
			5000	- 4	- 16	+ 4.0	⊙	
			7000	- 6	- 17	+ 4.6	○	
			100	70	- 1	- 14	+ 2.5	
				240	- 1	- 17	+ 3.0	
		500		- 2	- 19	+ 3.1	⊙	
		1000		- 3	- 23	+ 3.5	⊙	
		2000		- 3	- 29	+ 3.9	⊙	
		3000		- 4	- 36	+ 4.5	○	
		5000		- 6	- 50	+ 5.0	△	
		120	70	- 1	- 14	+ 3.2		
			240	- 1	- 17	+ 3.4		
500	- 2		- 34	+ 3.8	○			
1000	- 3		- 50	+ 4.5	○			
2000	- 4		- 65	+ 6.2	×			
3000	- 7		- 81	+ 11.0	×			
7000	- 8		- 62	+ 9.0	×			
DAFFNEY SUPER HYDRO HF46 (IDEMITSU)	A305	100	70	- 2	+ 2	- 0.2		
			168	- 2	- 1	- 0.5		
			500	+ 3	- 11	- 1.4	⊙	
			1000	+ 4	- 8	- 1.4	⊙	
	G506	120	70	+ 1	+ 7	- 1.3		
			168	+ 1	+ 3	- 1.0		
			500	+ 3	+ 2	- 0.9	⊙	
			1000	+ 3	0	- 0.6	⊙	
	G869	120	70	+ 3	+ 11	- 2.4		
			168	+ 3	+ 5	- 2.2		
			500	+ 4	+ 3	- 2.2	⊙	
			1000	+ 6	+ 1	- 1.7	○	
	U641	80	70	0	+ 2.8	+ 1.9		
			168	0	+ 3.6	+ 2.3		
			500	0	+ 1.9	+ 2.3	⊙	
			1000	0	+ 2.6	+ 2.2	⊙	
DAFFNEY SUPER HYDRO LW46 (IDEMITSU)	A305	100	70	- 5	+ 3	- 0.1		
			240	- 4	+ 1	- 1.5		
			500	- 3	+ 1	- 2.5	⊙	
	A795	100	70	+ 6	-	- 5.4	○	
	A980	100	70	- 1	+ 2	+ 0.2		
			240	0	0	+ 0.2		
			500	0	- 8	+ 0.6	⊙	
	U641	100	1000	- 1	- 7	+ 0.2	⊙	
	U801	100	1000	0	- 4	- 0.4	⊙	
	SUPER HIGH LAND 32 (NISSEKI)	A104	120	70	+ 3	- 3	- 2.5	○
A105		120	70	- 1	- 10	+ 0.4	○	
A305		120	70	- 1	+ 1	+ 0.5	○	
A505		120	70	- 1	- 9	- 1.6	○	
A626		120	70	- 1	- 6	+ 0.9	○	
A980		120	70	- 3	- 11	+ 4.9	○	
U801		100	1800	0	+ 12	+ 0.8	⊙	

DATA FOR REFERENCE

OIL RESISTANCE DATA

Brand name of sealing liquid (Manufacturer)		NOK's material symbol	Test temperature (°C)	Duration of test (H)	Change in hardness (points)	Change in tensile strength (%)	Change in volume (%)	Adaptable or not
Wear resistant hydraulic oil	SUPER HIGH LAND 56 (NISSEKI)	A104	120	70	+ 4	+ 3	- 3.9	○
		A105	120	70	- 1	- 9	- 0.6	○
		A305	120	70	- 2	- 3	- 0.4	○
		A505	120	70	+ 3	- 4	- 2.3	○
		A626	120	70	0	- 15	- 1.0	○
		A980	120	70	- 2	- 16	+ 2.8	○
		U641	100	1000	- 1	+ 8	- 0.3	○
	U801	100	1000	0	+ 2	+ 0.2	○	
	SUPER HIGH LAND Z46 (SHIN NISSEKI)	A505	100	70	0	+ 6	+ 0.2	
			280	0	+ 9	- 0.4		
			500	+ 2	+ 8	- 0.6	○	
		A980	100	70	- 1	+ 5	+ 2.5	
			280	0	- 1	- 1	+ 1.5	
			500	+ 2	- 4	+ 1.3	○	
		U641	100	70	- 1	- 1	+ 0.4	
			280	- 1	- 3	+ 0.4		
			500	- 1	- 7	+ 0.2	○	
		U801	100	70	0	- 2	- 1.2	
			280	0	+ 8	- 1.1		
			500	0	+ 14	- 1.4	○	
	COSMO HYDRO AW32 (COSMO)	A305	100	70	- 2	+ 1	- 0.3	
			168	- 1	+ 1	- 1.3	○	
		A980	100	70	+ 1	+ 4	+ 0.6	
			168	+ 2	- 4	+ 0.1	○	
	U593	100	168	0	- 13	+ 0.9	○	
	U801	100	168	0	+ 14	- 0.9	○	
	COSMO HYDRO AW46 (COSMO)	A305	100	70	- 3	- 1	- 0.7	
			168	- 2	- 4	- 1.8	○	
A980		100	70	+ 1	+ 3	- 0.3		
		168	+ 2	- 1	- 0.7	○		
U593	100	168	0	- 10	+ 0.8	○		
U801	100	168	0	+ 9	- 1.1	○		
COSMO HYDRO AW68 (COSMO)	A305	100	70	- 1	+ 1	- 1.5		
		168	0	- 1	- 2.3	○		
	A980	100	70	+ 1	+ 5	- 1.3		
		168	+ 3	0	- 1.7	○		
U593	100	168	0	- 16	+ 0.4	○		
U801	100	168	0	+ 12	- 1.1	○		
COSMO HYDRO LF22 (COSMO)	A305	100	70	- 4	- 4	+ 3.4		
		168	- 4	- 7	+ 2.4	○		
	A980	100	70	- 6	- 1	+ 8.2		
		168	- 4	- 9	+ 7.9	○		
U593	100	168	0	+ 4	+ 3.2	○		
U801	100	168	0	+ 1	+ 1.1	○		
COSMO HYDRO HV15 (COSMO)	A305	100	70	- 4	- 4	+ 2.5		
		168	- 3	+ 3	+ 1.5	○		
	A980	100	70	- 8	- 7	+ 6.9		
		168	- 7	- 9	+ 6.3	○		
U593	100	168	- 2	+ 1	+ 3.1	○		
U801	100	168	- 1	- 9	+ 0.7	○		
SEKI HYDRAX LT15 (KYOSEKI)	A903	80	70	- 6	0	+ 7.2	○	
		100	70	- 7	+ 1	+ 8.3	○	
KYOSEKI HYDRAX LT32 (KYOSEKI)	U593	100	500	- 6	- 56	+ 3.0	△	
		1000	- 8	- 76	+ 3.1	×		
U801	100	500	- 1	- 34	+ 0.2	○		
1000	- 1	- 71	+ 0.4	×				
DIAMOND HYDRO FLUID EP46 (MITSUBISHI PETROL)	A980	100	70	0	- 1	- 1.1	○	
TERRASSE OIL 32 (SHOWA-SHELL)	G928	100	70	- 2	- 4	+ 3.1		
		250	- 2	- 5	+ 3.2			
		500	- 1	- 3	+ 3.7	○		
	120	70	- 2	- 3	+ 3.7			
		250	- 1	- 6	+ 3.5			
500	- 1	- 6	+ 3.8	○				

OIL RESISTANCE DATA

Brand name of sealing liquid (Manufacturer)	NOK's material symbol	Test temperature (°C)	Duration of test (H)	Change in hardness (points)	Change in tensile strength(%)	Change in volume (%)	Adaptable or not		
Wear resistant hydraulic oil	TERRASSE OIL 32 (SHOWA-SHELL)	100	70	0	- 4	+ 1.9			
			250	0	+ 5	+ 1.9			
			500	- 1	+ 6	+ 2.0	○		
		120	70	- 1	- 5	+ 2.5			
			250	- 1	- 16	+ 2.0			
			500	- 1	- 37	+ 2.7	○		
		U801	100	70	0	+ 6	+ 0.1		
				250	0	+ 6	+ 0.2		
				500	0	+ 17	+ 0.1	○	
			120	70	0	0	+ 0.3		
				250	0	- 17	- 0.1		
				500	- 1	- 78	- 0.1	×	
	UH05	100	70	- 3	- 2	+ 6.8			
			250	- 3	- 3	+ 6.9			
			500	- 4	- 3	+ 7.2	○		
		120	70	- 3	- 11	+ 7.4			
			250	- 4	- 17	+ 7.9			
			500	- 4	- 46	+ 8.5	○		
	TERRASSE OIL K32 (SHOWA-SHELL)	U801	100	500	0	+ 5	+ 0.8	○	
	TERRASSE OIL 45 (SHOWA-SHELL)	U641	100	1000	- 1	- 49	+ 1.7	○	
		U801	100	500	0	- 10	+ 0.1	○	
			1000	+ 1	- 77	- 1.5	×		
	TERRASSE OIL 46 (SHOWA-SHELL)	A505	100	70	- 1	+ 7	- 0.3		
				150	0	+ 6	- 0.8		
300				+ 1	+ 12	- 1.2			
500				+ 3	+ 12	- 1.2	○		
120			70	- 1	+ 7	- 0.2			
			150	+ 1	+ 6	- 0.8			
			300	+ 2	+ 7	- 1.3			
			500	+ 5	- 5	- 1.2	○		
A980			100	70	- 3	+ 5	+ 2.1		
				280	- 2	+ 8	+ 1.8		
				500	+ 1	+ 13	+ 1.1	○	
G506			100	70	+ 1	- 2	- 1.3		
		150		+ 1	+ 3	- 0.9			
		300		+ 2	- 1	- 1.0			
		500		+ 2	0	- 1.1	○		
		120	70	+ 1	+ 2	- 1.1			
			150	+ 1	- 5	- 0.9			
			300	+ 2	- 2	- 1.1			
			500	+ 2	- 4	- 0.9	○		
U641		100	70	- 1	0	+ 1.2			
			280	- 1	0	+ 1.3			
			500	- 2	- 6	+ 1.4	○		
U801		100	70	- 1	+ 9	+ 0.2			
			280	- 1	+ 11	+ 0.6			
	500		- 1	+ 11	+ 1.2	○			
TERRASSE OIL K46 (SHOWA-SHELL)	G506	100	168	0	- 3	- 2.0	○		
		120	168	- 1	- 2	- 0.2	○		
TERRASSE OIL 56 (SHOWA-SHELL)	A104	120	70	+ 4	+ 1	- 3.8	○		
	A105	120	70	0	- 21	- 0.5	○		
	A305	120	70	- 1	- 1	- 0.5	○		
	A505	120	70	+ 1	- 20	- 1.2	○		
	A626	120	70	- 2	- 2	- 1.2	○		
	A980	120	70	- 2	- 6	+ 2.4	○		
	U641	100	1500	0	- 6	+ 1.4	○		
	U801	100	1500	0	- 42	- 0.5	○		
TERRASSE OIL K100 (SHOWA-SHELL)	G506	100	168	+ 1	+ 4	- 1.5	○		
		120	168	+ 2	- 3	- 1.4	○		

OIL RESISTANCE DATA

Brand name of sealing liquid (Manufacturer)		NOK's material symbol	Test temperature (°C)	Duration of test (H)	Change in hardness (points)	Change in tensile strength (%)	Change in volume (%)	Adaptable or not			
Wear resistant hydraulic oil	NUTOH H15 (ESSO)	A305	100	70	- 4	- 5	+ 2.9	○			
				168	- 3	- 1	+ 2.1				
		NUTOH HP68 (ESSO)	A980	100	70	- 5	- 4	+ 7.2	○		
					168	- 6	- 15	+ 6.6			
	UNIPower SQ32 (ESSO)		U593	100	168	- 4	- 14	+ 3.0	△		
					U801	100	168	- 1		- 8	+ 0.9
			UNIPower SQ46 (ESSO)	A104	120	70	+ 4	+ 5	- 3.1	○	
						A105	120	70	- 1		- 7
	UNIPower SQ68 (ESSO)	A305		120	70	- 2	+ 4	+ 0.4	○		
					A505	120	70	- 1		- 8	+ 0.3
		MOBIL DTE26 (MOBIL)		A626	120	70	0	+ 2	- 1.0	○	
						A980	120	70	- 2		- 6
	UNIPower SQ32 (ESSO)		U593	100	168	+ 1	- 4	+ 1.8	○		
					U801	100	168	+ 1		- 3	- 0.1
			UNIPower SQ46 (ESSO)	U593	100	168	+ 1	- 1	+ 1.7	○	
						U801	100	168	+ 1		0
	UNIPower SQ68 (ESSO)	U593	100	168	+ 1	- 3	+ 1.3	○			
				U801	100	168	+ 1		- 6	- 0.3	
		MITSUI HIDICK AW46 (MITSUI PETROL)	A104	120	70	+ 5	- 5	- 4.2	○		
					A105	120	70	+ 1		- 15	- 0.9
					A305	120	70	0		- 4	- 1.1
			A505	120	70	70	+ 1	- 15	- 1.8	○	
	A626					120	70	0	- 11		- 2.2
	A980					120	70	0	- 19		- 0.8
	MITSUI HIDICK AW46 (MITSUI PETROL)	U801	100	1000	+ 1	+ 20	+ 0.6	○			
				A505	100	240	+ 1		+ 3	- 0.7	○
						500	+ 1		+ 3	- 0.8	
		1000	+ 3			+ 3	- 0.8				
A980		100	240	+ 1	- 2	+ 0.6	○				
			500	+ 3	- 3	+ 0.4					
	1000		+ 5	- 8	+ 0.1						
U801	100	1000	0	- 1	- 0.4	○					
		U593	100	1000	+ 1		+ 7	+ 0.2			
U641	100	1000	0	- 11	+ 0.4	○					
Wear resistant hydraulic oil (with improved viscosity and temperature characteristic)	DAFFNEY SUPER HYDRO 22WR (IDEMITSU)	U593	100	168	+ 1	- 1	+ 3.1	○			
				U801	100	168	+ 1		+ 6	+ 1.1	
	DAFFNEY SUPER HYDRO 32WR (IDEMITSU)	A104	100	70	- 2	+ 10	- 2.6	○			
				A105	100	70	- 1		- 12	+ 0.5	
		A305	100	70	- 3	- 2	+ 0.3	○			
				A505	100	70	- 2		0	+ 0.9	
			A626	100	70	- 3	+ 3	- 1.3	○		
					A980	100	70	- 5		+ 6	+ 2.1
	DAFFNEY SUPER HYDRO 46WR (IDEMITSU)	A104	100	70	+ 2	+ 1	- 4.0	○			
				A795	100	70	+ 2		- 4	- 4.3	
		U593	100	1000	0	- 8	+ 0.1	○			
				U641	100	1000	0		+ 18	+ 0.1	
			U801	100	1000	+ 1	+ 7	- 1.2	○		
					HIGH LAND WIDE 15 (NISSEKI)	A305	100	70		- 6	- 6
	168	- 5	- 5	+ 3.3							
	A980	100	70	- 10		- 3	+ 10.1	○			
			168	- 9		- 1	+ 9.6				
	U593	100	168	- 2	+ 5	+ 4.4	○				
			U801	100	168	- 1		- 6	+ 1.8		
	HIGH LAND AH15 (NISSEKI)	A505	100	70	- 4	- 2	+ 4.9	○			
				A903	100	70	- 1		- 5	+ 1.8	
	COSMO HYDRO HV32 (COSMO)	U593	120	1000	- 1	- 27	+ 0.2	○			
				U801	120	1000	0		- 45	- 1.6	
	COSMO HYDRO HV56 (COSMO)	U593	100	1000	- 4	- 41	+ 0.8	○			
				U801	100	1000	0		- 43	- 0.9	
	TERRASSE OIL KT32 (SHOWA-SHELL)	G506	120	168	0	+ 1	+ 0.6	○			
	TERRASSE OIL R32 (SHOWA-SHELL)	U641	120	300	0	+ 3	+ 1.2	○			
				U801	120	300	0		- 2	- 0.1	

OIL RESISTANCE DATA

Brand name of sealing liquid (Manufacturer)		NOK's material symbol	Test temperature (°C)	Duration of test (H)	Change in hardness (points)	Change in tensile strength(%)	Change in volume (%)	Adaptable or not	
Wear resistant hydraulic oil (with improved viscosity and temperature characteristic)	TERRASSE OIL ST32 (SHOWA-SHELL)	A505	100	70	- 2	+ 7	+ 0.9		
			280	- 1	+ 9	+ 0.2			
			500	+ 2	+ 15	+ 0.2	○		
		A980	100	70	- 2	+ 4	+ 0.8		
			280	- 1	+ 6	+ 0.8			
			500	+ 2	+ 2	+ 0.1	○		
		U641	100	70	- 1	0	+ 1.2		
			280	- 1	0	+ 1.3			
			500	- 1	- 5	+ 1.7	○		
		U801	100	70	- 1	+ 11	+ 0.3		
			280	- 1	+ 14	+ 0.7			
			500	- 1	+ 14	+ 1.3	○		
	DIAMOND HYDRO-FLUID W32 (MITSUBISHI PETROL)	U801	100	1130	0	+ 12	+ 0.6	○	
	MOBIL DTE11 (MOBIL)	A305	100	70	- 4	- 13	+ 2.1		
			168	- 4	- 10	+ 3.4	○		
		A980	100	70	- 5	- 4	+ 10.3		
			168	- 5	0	+ 10.6	○		
	MOBIL DTE13 (MOBIL)	U593	100	168	- 2	- 4	+ 4.0	○	
		U801	100	168	- 1	- 1	+ 2.0	○	
A104		120	70	+ 2	- 9	- 1.0	○		
A105		120	70	- 1	- 19	+ 1.6	○		
A305		120	70	- 2	- 11	+ 2.1	○		
A505		120	70	0	- 17	+ 0.5	○		
A626		120	70	- 3	- 21	+ 2.8	△		
A980		120	70	- 5	- 16	+ 7.5	○		
U801	120	1000	0	+ 9	+ 2.0	○			
Worm gear oil	OMARA OIL 150 (SHOWA-SHELL)	U801	100	168	0	0	0	○	
Flame retardant hydraulic oil	(Phosphate)	HIGH LAND FRP46 (NISSEKI)	A795	100	200	- 30	-	+ 97.4	×
			F548	100	200	- 4	- 24	+ 12.1	○
			F975	100	200	- 9	- 15	+ 14.0	○
		150		200	- 11	- 18	+ 17.6	△	
		SFR FLUID D46 (SHOWA-SHELL)	A505	100	70	- 19	- 67	+ 77.5	×
			F268	100	70	- 5	+ 3	+ 3.0	
		168		- 6	- 8	+ 4.1	○		
		COSMO LUBRIC HF130 (E.F. HORTON)	G506	100	70	- 4	+ 2	+ 3.1	
					240	- 3	+ 2	+ 3.9	
	500				- 3	+ 1	+ 4.5	○	
	120			70	- 3	+ 1	+ 3.8		
				240	- 3	+ 2	+ 4.1		
				500	- 2	+ 8	+ 5.4	○	
	U641		80	500	0	+ 12	+ 2.2	○	
			100	500	0	- 7	+ 2.4	○	
			120	500	0	- 37	+ 2.8	○	
	QUINTLEPLIC 822-200 (JAPAN QUAKER CHEMICAL)		A795	80	70	0	+ 9	- 0.1	○
	QUINTLEPLIC 822-300 (JAPAN QUAKER CHEMICAL)		A402	100	70	- 8	- 19	+ 9.1	○
			A980	100	70	- 13	- 11	+ 18.0	△
			F201	100	70	- 3	- 5	+ 0.4	○
			A505	100	70	- 4	+ 9	+ 2.3	
				240	- 5	+ 11	+ 2.7		
		500		- 5	+ 8	+ 4.7	○		
	G869	100	70	+ 1	+ 6	- 1.9			
		240	+ 1	+ 4	- 1.1				
		500	+ 1	+ 7	- 0.7	○			
	U641	100	70	0	+ 33	+ 2.1			
240		0	+ 15	+ 2.8					
500		- 1	- 20	+ 3.3	○				
U801	100	70	- 1	+ 37	+ 2.2				
	240	- 2	- 66	+ 1.6					
	500	- 2	- 78	- 0.3	×				
HORTSAFE HF130 (HORTON)	U801	100	72	- 1	0	+ 5.9			
		144	- 2	- 19	+ 6.5				
		300	- 2	- 37	+ 7.2	×			

OIL RESISTANCE DATA

Brand name of sealing liquid (Manufacturer)		NOK's material symbol	Test temperature (°C)	Duration of test (H)	Change in hardness (points)	Change in tensile strength(%)	Change in volume (%)	Adaptable or not		
Flame retardant hydraulic oil	〈Fatty acid ester base〉	DAFFNEY FURTHEST ES (IDEMITSU)	A505	100	70	- 7	+ 7	+ 4.9	○	
					240	- 6	+ 1	+ 4.7		
					500	- 6	+ 14	+ 4.8		
			G869	100	70	- 2	+ 6	+ 1.8	○	
					240	- 2	+ 7	+ 2.5		
					500	- 1	+ 8	+ 2.4		
			U641	100	70	0	+ 6	+ 3.6	○	
					240	- 1	+ 13	+ 4.3		
					500	- 1	+ 5	+ 4.9		
			U801	100	70	- 1	+ 21	+ 3.8	○	
					240	- 1	+ 24	+ 4.4		
					500	- 2	- 36	+ 4.9		
		HIGH LAND FRG46 (NISSEKI)	A104	100	70	- 8	- 1	+ 4.2	○	
			A402	100	70	- 8	- 18	+ 8.4	○	
			A505	100	70	- 3	0	+ 2.6	○	
			A980	100	70	- 3	- 6	0	○	
			A795	80	70	- 3	- 2	+ 3.5	○	
		COSMO FLUID GS46 (COSMO)	A795	80	70	- 3	+ 3	+ 3.5	○	
		COSMO FLUID HQ46 (COSMO)	A795	80	70	- 4	- 5	+ 3.4	○	
		IRUS FLUID C (SHOWA-SHELL)	A104	100	70	- 6	- 7	+ 0.8	○	
			A402	100	70	- 5	- 22	+ 1.9	○	
			A505	100	70	0	+ 6	+ 0.8	○	
			A980	100	70	- 1	- 7	- 1.1	○	
		HI-DOLL HAW (MATSUMURA PETROL)	A104	100	70	- 8	- 2	+ 5.6	○	
	100			70	- 6	- 9	+ 10.0	○		
	A505		70	70	- 3	+ 10	+ 4.4	○		
			100	70	- 4	- 2	+ 5.7	○		
	A980		70	70	- 2	0	+ 2.6	○		
			100	70	- 2	- 8	+ 0.4	○		
	A795	80	70	- 4	+ 5	+ 4.5	○			
	〈Water, glycol base〉	HI-DOLL HAW(S) (MATSUMURA PETROL)	A505	80	70	- 6	+ 1	+ 4.4	○	
					240	- 4	+ 3	+ 4.1		
					500	- 3	+ 2	+ 2.7		
					1000	- 2	+ 7	+ 0.6		
				100	70	- 6	+ 3	+ 4.6	○	
					240	- 3	+ 2	+ 1.8		
					500	- 3	+ 4	+ 0.8		
					1000	- 2	+ 5	+ 0.1		
			A626	80	70	- 7	- 1	+ 2.4	○	
						240	- 3	+ 2		+ 1.5
						500	- 3	+ 2		- 0.3
						1000	- 2	+ 9		- 3.2
			100	70	- 7	- 3	+ 1.7	○		
				240	- 3	+ 1	- 1.6			
				500	- 2	+ 1	- 4.8			
				1000	0	+ 1	- 6.4			
		A980	80	70	- 4	+ 2	+ 0.9	○		
					240	- 3	- 1		+ 3.5	
					500	- 2	- 1		+ 2.0	
					1000	0	+ 1		+ 0.1	
			100	70	- 3	+ 3	+ 3.4	○		
				240	0	+ 4	+ 0.1			
				500	+ 3	- 3	- 4.7			
				1000	+ 6	- 2	- 8.0			
	G869	80	70	0	- 1	- 2.6	○			
				240	+ 2	+ 2		- 2.4		
				500	+ 2	- 2		- 3.1		
				1000	+ 2	+ 3		- 3.6		
			100	70	+ 1	+ 1	- 1.7	○		
				240	+ 2	+ 4	- 2.5			
				500	+ 2	+ 2	- 2.7			
				1000	+ 2	+ 5	- 2.6			

OIL RESISTANCE DATA

Brand name of sealing liquid (Manufacturer)		NOK's material symbol	Test temperature (°C)	Duration of test (H)	Change in hardness (points)	Change in tensile strength(%)	Change in volume (%)	Adaptable or not												
Flame retardant hydraulic oil	Water, glycol base	HI-DOLL HAW(S) (MATSUMURA PETROL)	80	70	- 3	- 6	+ 3.6													
				240	- 3	- 3	+ 3.6													
				500	- 2	- 5	+ 2.7	○												
				1000	- 1	- 6	+ 2.3	○												
		100	U641	80	70	- 3	- 8	+ 4.5												
					240	- 2	- 4	+ 3.1												
					500	- 2	- 5	+ 2.1	○											
					1000	- 1	- 4	+ 2.2	○											
		U652	80	70	70	- 3	- 15	+ 3.8												
					240	- 4	- 59	+ 3.9												
					500	- 4	- 80	+ 4.5	×											
					1000	- 4	- 85	+ 3.7	×											
	U801	80	70	70	- 3	- 38	+ 6.1													
				240	- 4	- 88	+ 5.7	×												
				500	- 4	- 88	+ 7.9	×												
				1000	- 4	- 88	+ 7.9	×												
	Water soluble oil	HI-DOLL HAW-32 (MATSUMURA PETROL)	A795	80	70	- 4	+ 1	+ 4.4	○											
					HI-DOLL H200 (MATSUMURA PETROL)	F268	175	70	- 14	- 27	+ 26.7	×								
													HORTSAFE 72 (E.F.HORTON)	A105	70	70	- 1	- 3	+ 2.3	
																240	- 2	0	+ 3.4	
		500	- 2	- 2												+ 6.1	○			
		1000	+ 3	- 10	+ 2.8	○														
		A305	70	70	70	- 4	- 6	+ 2.8												
					240	- 6	- 3	+ 5.4												
500					- 6	- 7	+ 9.3	○												
1000					- 4	- 6	+ 3.7	○												
A980		70	70	70	- 2	- 6	+ 1.9													
				240	- 3	- 1	+ 2.1													
	500			- 3	- 2	+ 2.1	○													
	1000			+ 2	- 10	- 2.9	○													
SYNLUBE M-46 (NIPPON STEEL CHEMICAL)	F268	100	70	- 4	- 3	+ 2.3	○													
			175	70	- 14	- 19	+ 22.3	△												
	F975	100	70	70	- 1	- 22	+ 6.8	△												
				175	70	- 5	- 80	+ 29.7	×											
	G869	100	70	70	+ 2	+ 9	- 3.3	○												
				175	70	- 4	- 1	+ 4.9	△											
Emulsion type	HYDROLUBLIC 120B 5% SOLUTION (E.F. HORTON)	U641	60	420	0	- 7	+ 2.3	○												
				80	420	- 1	- 25	+ 2.7	○											
		U801	60	420	420	- 1	- 13	+ 3.2	○											
					80	250	- 2	- 40	+ 4.0	×										
		DAFFNEY FURTHEST WO46 (IDEMITSU)	A505	80	168	- 7	- 3	+ 13.4												
					500	- 8	- 4	+ 12.9	○											
	A795		80	168	168	- 10	- 9	+ 11.7												
					500	- 12	- 15	+ 12.1	△											
	A980		80	168	168	- 13	- 7	+ 26.3												
					500	- 19	- 5	+ 29.7	×											
	G506	80	168	168	- 6	- 19	+ 9.7													
				500	- 13	- 21	+ 9.8	△												
U641	80	168	168	- 4	- 35	+ 9.7														
			500	- 4	- 51	+ 9.9	△													
TURBINE OIL	140 TURBINE OIL (IDEMITSU)	A505	100	70	0	0	- 0.7	○												
	180 TURBINE OIL (IDEMITSU)	A505	100	70	+ 1	+ 3	- 0.9	○												
	FBK TURBINE 90 (NISSEKI)	A105	100	70	70	- 2	- 3	+ 1.7	○											
					70	- 2	- 14	+ 0.5	○											
					70	- 3	- 8	+ 0.9	○											
TURBINE OIL 32 (NISSEKI)	U801	100	1000	+ 1	+ 2	+ 0.7	○													
Sliding face Lubricant	UNIWAY 68 (NISSEKI)	U801	100	1000	+ 1	+ 17	+ 1.5	○												

DATA FOR REFERENCE

OIL RESISTANCE DATA

Brand name of sealing liquid (Manufacturer)		NOK's material symbol	Test temperature (°C)	Duration of test (H)	Change in hardness (points)	Change in tensile strength(%)	Change in volume (%)	Adaptable or not
Machine Oil	No.2 SPINDLE OIL (NISSEKI)	A105	100	70	- 5	- 4	+ 9.4	○
		A305	100	70	- 9	- 22	+ 10.8	○
		A505	100	70	- 6	- 10	+ 9.7	○
		F548	120	200	0	-	+ 1.6	○
GREASE FOR VEHICLES	APPOLOIL AUTOREX A (IDEMITSU)	A305	80	70	0	+ 3	+ 2.0	○
		A795	100	200	+ 5	- 7	- 4.7	○
		U695	100	750	- 1	- 43	+ 1.3	○
			1000	- 1	- 56	+ 1.2	△	
	APPOLOIL AUTOREX C (IDEMITSU)	U641	100	1000	- 2	0	0	○
		U801	100	1000	- 1	+ 15	+ 0.2	○
	DAFFNEY CORONEX GREASE No.2 (IDEMITSU)	U801	70	1000	- 1	+ 9	+ 2.3	○
	DIAMOND MULTI-PURPOSE GREASE No.2 (IDEMITSU)	U801	70	1000	- 1	+ 10	+ 2.6	○
	CHASSIS GREASE 2 (SHOWA-SHELL)	U801	100	168	0	+ 18	+ 3.4	○
	ALBANIA GREASE 2 (SHOWA-SHELL)	U801	100	500	0	- 57	+ 2.4	△
	ALBANIA GREASE RA (SHOWA-SHELL)	U801	100	500	0	- 70	+ 2.2	×
	ALBANIA EP GREASE 2 (SHOWA SHELL)	U641	100	500	- 3	- 10	+ 3.0	○
		U801	100	500	- 2	- 75	+ 3.9	×
	CHASSIS GREASE No.2 (NISSEKI)	U695	100	1000	- 2	- 15	+ 4.7	○
			120	1000	- 2	- 35	+ 5.3	○
	SEMI-COAT GREASE No.2 (GENERAL PETROL)	U801	80	168	0	- 13	+ 2.4	○
	CENTPLEX 2 (NOK KLUEBER)	A305	100	70	- 7	+ 1	+ 1.9	○
			168	- 5	+ 1	+ 1.2		
		A980	100	70	- 5	+ 5	+ 5.0	○
			168	- 4	0	+ 4.5		
	U593	100	168	0	- 1	+ 0.3	○	
	U801	100	168	- 1	- 69	+ 1.0	×	
	ONE LOOPER No. 2 (KYODO GREASE)	A305	80	70	- 7	+ 1	+ 4.9	○
	MARUTEMP TA No.2 (KYODO GREASE)	U801	100	168	0	+ 1	+ 2.4	○
	CASTLE MP GREASE (TOYOTA MOTORS GENUINE)	A305	80	70	- 6	- 4	+ 4.8	○
	CASTLE CHASSIS GREASE SPECIAL (TOYOTA MOTORS GENUINE)	U695	100	1000	- 1	- 9	+ 3.0	○
			120	1000	- 2	- 15	+ 3.5	○
	BLUE RIBBON BEARING GREASE (HINO MOTOR SALES GENUINE)	A305	80	70	- 6	+ 6	+ 2.9	○
	SUNLIGHT GREASE (SHOWA SHELL)	U801	100	200	- 1	+ 4	+ 1	○
			400	- 1	+ 7	+ 1		
			600	- 1	+ 8	+ 1		
			800	0	+ 11	+ 1		
			1000	0	+ 16	+ 1		
	DAFFNEY EPONEX GREASE SR2 (IDEMITSU)	A156	100	70	0	+ 7	- 1.7	○
			166	+ 2	- 2	- 2.6		
		A305	100	70	- 2	+ 1	- 1.1	○
166			- 2	0	- 2.2			
A527		100	70	+ 1	0	- 0.6	○	
		166	+ 1	+ 4	- 1.2			
A567		100	70	+ 5	+ 5	- 7.7	△	
		166	+ 6	+ 4	- 8.2			
A727		100	70	0	+ 8	- 1.4	○	
		166	- 2	+ 1	- 1.2			
A980	100	70	+ 2	+ 8	- 3.9	○		
	166	+ 2	+ 4	- 4.2				
U652	100	70	0	+ 21	+ 0.5	○		
	166	0	+ 11	+ 0.3				
DAFFNEY EPONEX GREASE SR2 (IDEMITSU)	U801	100	70	0	+ 19	- 0.6	○	
		166	0	+ 9	- 0.5			
DAFFNEY MOLYBDENUM GREASE (IDEMITSU)	U801	100	70	0	- 14	+ 2.7	○	
		210	0	- 65	+ 3.1			
		300	0	- 58	+ 3.0			
Industrial grease	MOBIL TAK 81 (MOBIL)	A505	100	1000	+ 4	- 20	+ 0.4	○
	GOLD No.2 (JAPAN GREASE)	U801	100	168	0	+ 1	+ 2.7	○
	STABRUGGS NBU30G5 (NOK KLUEBER)	A505	100	1000	+ 6	+ 4	- 0.3	○
	SYNTHESSO PROBA270 (NOK KLUBER)	A168	100	70	- 2	+ 6	+ 2.1	○

OIL RESISTANCE DATA

Brand name of sealing liquid (Manufacturer)		NOK's material symbol	Test temperature (°C)	Duration of test (H)	Change in hardness (points)	Change in tensile strength(%)	Change in volume (%)	Adaptable or not		
Other grease	No115 SPRAY GREASE (NICHIMORI)	A305	100	70	- 5	0	- 2.3			
				168	- 4	+ 3	- 3.2	○		
	DAFFNEY SPRAY GREASE (IDEMITSU)	A305	100	70	+ 2	+ 4	- 3.5			
				168	+ 3	+ 4	- 3.6	○		
Other grease	DAFFNEY SPRAY GREASE (IDEMITSU)	A305	100	70	- 5	+ 2	+ 1.4			
				168	- 5	+ 5	+ 0.6	○		
	DAFFNEY SPRAY GREASE (IDEMITSU)	A980	100	70	- 3	+ 1	+ 2.9			
				168	- 2	+ 2	+ 2.7	○		
PROCESSING OIL (Cutting oil)	YUSHIOKEN EC50T3 50% SOLUTION (YUSHIRO KAGAKU)	U641	80	168	- 2	- 13	+ 2.4	○		
				U801	80	168	- 2	- 13	+ 2.7	○
	YUSHIOKEN EC50T3 30 times dilution (YUSHIRO KAGAKU)	A105	70	70	- 13	- 11	+ 17.8			
				168	- 13	- 11	+ 18.6			
				336	- 13	- 12	+ 18.4			
				500	- 13	- 8	+ 18.7	△		
	YUSHIOKEN EC50T3 30 times dilution (YUSHIRO KAGAKU)	A305	70	70	- 10	- 13	+ 16.3			
				168	- 11	- 15	+ 17.4			
				336	- 10	- 15	+ 17.2			
				500	- 10	- 13	+ 17.2	△		
	YUSHIOKEN EC50T3 30 times dilution (YUSHIRO KAGAKU)	A305	70	1000	- 11	- 15	+ 17.1	△		
				A505	70	70	- 5	- 1	+ 5.6	
						168	- 5	- 1	+ 6.3	
						336	- 5	- 1	+ 10.4	
	500	- 6	- 6			+ 10.3				
	YUSHIOKEN EC50T3 30 times dilution (YUSHIRO KAGAKU)	A505	70	1000	- 5	+ 4	+ 9.9	○		
				A795	70	70	- 10	- 6	+ 10.2	
						168	- 12	- 8	+ 13.2	
						336	- 14	- 13	+ 16.4	
	500	- 15	- 12			+ 18.5	×			
	YUSHIOKEN EC50T3 30 times dilution (YUSHIRO KAGAKU)	A795	70	1000	- 16	- 9	+ 22.3	×		
				A980	70	70	- 5	- 4	+ 6.0	
						168	- 6	- 5	+ 7.3	
						336	- 6	- 4	+ 9.0	
	500	- 6	+ 1			+ 10.4	○			
	YUSHIOKEN EC50T3 30 times dilution (YUSHIRO KAGAKU)	A980	70	1000	- 8	+ 1	+ 12.7	○		
				F201	70	70	- 6	+ 1	+ 13.7	
						168	- 4	- 27	+ 28.1	
						336	- 3	- 42	+ 42.5	
	500	- 3	- 50			+ 41.2	×			
	YUSHIOKEN EC50T3 30 times dilution (YUSHIRO KAGAKU)	F201	70	1000	- 8	- 53	+ 62.7	×		
				G506	70	70	- 2	+ 1	+ 2.5	
						168	- 2	- 1	+ 3.8	
						336	- 3	- 4	+ 3.5	
	500	- 3	- 5			+ 4.3				
	YUSHIOKEN EC50T3 30 times dilution (YUSHIRO KAGAKU)	G506	70	1000	- 3	0	+ 6.5	○		
				G869	70	70	0	- 3	+ 1.2	
						168	- 1	+ 1	+ 2.5	
						336	- 1	- 2	+ 2.6	
	500	- 2	- 8			+ 3.9	○			
	YUSHIOKEN EC50T3 30 times dilution (YUSHIRO KAGAKU)	G869	70	1000	- 2	- 2	+ 5.2	○		
				U593	70	70	- 2	- 19	+ 4	
						168	- 5	- 36	+ 6	
						336	- 6	- 43	+ 7	
	500	- 12	- 68			+ 8	×			
	YUSHIOKEN EC50T3 30 times dilution (YUSHIRO KAGAKU)	U593	70	1000	- 12	- 68	+ 8	×		
				U641	70	70	- 3	- 13	+ 2	
						168	- 3	- 14	+ 5	
336						- 3	- 18	+ 5		
500	- 3	- 20	+ 5			○				
YUSHIOKEN EC50T3 30 times dilution (YUSHIRO KAGAKU)	U641	70	1000	- 3	- 29	+ 6	○			
			U801	70	70	- 3	- 32	+ 4		
					168	- 3	- 34	+ 5		
					336	- 3	- 35	+ 5		
500	- 3	- 56			+ 5	△				
YUSHIOKEN EC50T3 30 times dilution (YUSHIRO KAGAKU)	U801	70	1000	- 3	- 85	+ 5	×			

DATA FOR REFERENCE

OIL RESISTANCE DATA

Brand name of sealing liquid (Manufacturer)		NOK's material symbol	Test temperature (°C)	Duration of test (H)	Change in hardness (points)	Change in tensile strength(%)	Change in volume (%)	Adaptable or not
PROCESSING OIL (Cutting oil)	MULTICOOL CSF2000 20 times dilution (KYODO GREASE)	A505	80	72	- 5	- 3	+ 5.7	○
				240	- 5	0	+ 7.2	
				480	- 5	- 2	+ 7.8	
				720	- 4	- 2	+ 7.7	
		G506	80	72	- 4	- 6	+ 4.1	○
				240	- 3	- 1	+ 4.1	
				480	- 3	- 8	+ 4.3	
				720	- 4	- 9	+ 4.4	
		G869	80	72	- 5	- 1	+ 4.5	○
				240	- 4	+ 3	+ 4.2	
				480	- 5	- 11	+ 6.9	
				720	- 5	- 12	+ 7.3	
		U593	80	72	- 3	- 8	+ 4	×
				240	- 13	- 88	+ 7	
	U641	80	72	- 2	- 22	+ 3	○	
			240	- 3	- 27	+ 5		
			480	- 4	- 33	+ 5		
			720	- 4	- 42	+ 7		
	U801	80	72	- 2	- 18	+ 3	×	
			240	- 2	- 74	+ 4		
	MULTICOOL CSF5000 20 times dilution (KYODO GREASE)	A105	70	70	- 4	- 6	+ 2.1	○
				168	- 4	- 10	+ 3.4	
				336	- 4	- 9	+ 5.0	
				500	- 5	- 11	+ 6.1	
				1000	- 3	- 8	+ 4.1	
		A305	70	70	- 2	- 4	+ 2.0	○
				168	- 5	- 5	+ 3.3	
				336	- 5	- 4	+ 6.0	
				500	- 5	- 6	+ 7.2	
				1000	- 1	- 1	+ 5.4	
A505		70	70	- 3	+ 6	+ 2.2	○	
			168	- 4	+ 7	+ 3.5		
			336	- 4	+ 9	+ 4.2		
			500	- 4	+ 10	+ 3.7		
			1000	- 3	+ 7	+ 3.9		
A795		70	70	- 6	+ 12	+ 7.4	△	
			168	- 7	+ 11	+ 9.7		
			336	- 7	+ 12	+ 11.8		
			500	- 8	+ 12	+ 14.0		
			1000	- 10	+ 6	+ 18.1		
A980		70	70	- 2	+ 4	+ 2.6	○	
			168	- 2	+ 2	+ 2.2		
			336	- 2	+ 1	+ 1.8		
			500	- 2	- 1	+ 1.6		
			1000	- 1	- 5	+ 1.2		
F201		70	70	- 2	- 13	+ 2.8	○	
			168	- 3	- 11	+ 4.3		
			336	- 3	- 17	+ 5.8		
	500		- 3	- 24	+ 7.0			
	1000		- 2	+ 2	+ 8.8			
G506	70	70	+ 1	+ 7	- 0.5	○		
		168	+ 1	+ 8	- 0.3			
		336	+ 1	+ 8	- 0.9			
		500	+ 1	+ 8	- 1.1			
		1000	+ 1	+ 8	- 1.0			
G869	70	70	0	+ 7	- 0.4	○		
		168	+ 1	+ 12	- 1.0			
		336	+ 1	+ 10	- 1.7			
		500	+ 2	+ 14	- 2.0			
		1000	+ 2	+ 10	- 1.9			
U593	70	70	- 3	- 12	+ 3	×		
		168	- 3	- 9	+ 3			
		336	- 7	- 37	+ 5			
		500	- 11	- 77	+ 6			

OIL RESISTANCE DATA

Brand name of sealing liquid (Manufacturer)		NOK's material symbol	Test temperature (°C)	Duration of test (H)	Change in hardness (points)	Change in tensile strength(%)	Change in volume (%)	Adaptable or not
PROCESSING OIL <Cutting oil>	MULTICOOL CSF5000 20 times dilution (KYODO GREASE)	U641	70	70	- 1	- 8	+ 2	
				168	- 1	- 7	+ 1	
				336	- 2	- 19	+ 1	
				500	- 2	- 19	+ 2	○
				1000	- 2	- 30	+ 2	○
		U801	70	70	- 1	- 5	+ 2	
				168	- 1	+ 4	+ 2	
				336	- 2	- 14	+ 3	
				500	- 2	- 73	+ 3	×
				1000	- 2	- 83	+ 4	×
	SUGICUT CS68-JR 20 times dilution (SUGIMURA CHEMICAL)	A105	70	70	- 5	- 7	+ 4.2	
				168	- 6	- 14	+ 6.1	
				336	- 6	- 10	+ 7.6	
				500	- 6	- 7	+ 8.0	○
				1000	- 7	- 11	+ 11.3	○
		A305	70	70	- 5	- 4	+ 4.4	
				168	- 5	- 5	+ 6.8	
				336	- 6	- 5	+ 8.8	
				500	- 6	- 2	+ 9.2	○
				1000	- 7	- 7	+ 14.5	○
	A505	70	70	- 4	+ 6	+ 4.2		
			168	- 6	+ 9	+ 5.9		
			336	- 6	+ 4	+ 7.7		
			500	- 6	+ 8	+ 8.5	○	
			1000	- 6	+ 5	+ 9.6	○	
	A795	70	70	- 7	+ 13	+ 8.9		
			168	- 10	+ 14	+ 12.0		
			336	- 12	- 4	+ 16.7		
			500	- 12	- 10	+ 19.0	×	
			1000	- 14	- 16	+ 23.9	×	
	A980	70	70	- 4	+ 3	+ 4.0		
			168	- 5	+ 7	+ 5.4		
			336	- 6	+ 4	+ 7.0		
			500	- 6	+ 5	+ 7.9	○	
			1000	- 5	+ 3	+ 8.7	○	
	F201	70	70	- 3	- 8	+ 4.8		
			168	- 4	- 16	+ 7.6		
			336	- 5	- 17	+ 12.7		
			500	- 6	- 21	+ 14.7	○	
			1000	- 6	- 30	+ 27.3	×	
G506	70	70	0	+ 6	+ 1.5			
		168	- 1	+ 7	+ 2.0			
		336	- 2	+ 5	+ 3.4			
		500	- 2	+ 6	+ 4.9	○		
		1000	- 2	0	+ 5.7	○		
G869	70	70	+ 1	+ 12	+ 0.3			
		168	0	+ 10	+ 0.6			
		336	- 1	+ 10	+ 1.3			
		500	- 1	+ 10	+ 2.1	○		
		1000	- 1	+ 11	+ 2.9	○		
U593	70	70	- 3	- 15	+ 4			
		168	- 3	- 16	+ 5			
		336	- 9	- 52	+ 6	×		
U641	70	70	- 2	- 10	+ 2			
		168	- 2	- 9	+ 2			
		336	- 3	- 19	+ 4			
		500	- 3	- 24	+ 4	○		
		1000	- 3	- 40	+ 6	○		
U801	70	70	- 1	- 1	+ 3			
		168	- 1	+ 5	+ 4			
		336	- 1	- 29	+ 5			
		500	- 1	- 79	+ 6	×		

OIL RESISTANCE DATA

Brand name of sealing liquid (Manufacturer)		NOK's material symbol	Test temperature (°C)	Duration of test (H)	Change in hardness (points)	Change in tensile strength(%)	Change in volume (%)	Adaptable or not
PROCESSING OIL	Cutting oil (NORITAKE COOL NK88 50 times dilution (NORITAKE) SULKRAT X-350C (KYODO GREASE))	A305	80	200	+ 1	0	+ 3.5	○
		G607	80	200	+ 1	0	- 1.9	○
		U801	70	72 144 300	- 3 - 3 - 3	- 20 - 18 - 23	+ 22.7 + 26.7 + 29.3	×
	Laminating oil (MOBIL MTJ-200C (MOBIL) MOBIL MTJ-200C 6% SOLUTION (MOBIL))	A505	100	70	- 12	- 2	+ 16.6	△
		U801	80	70	0	- 49	+ 2.4	×
		A104	80	70	- 7	- 3	+ 14.6	○
	Anti-rust oil (ST BOUSEI K2171 (MOBIL))	A505	80	70	- 6	+ 2	+ 13.3	○
		A104	25	70	- 12	- 14	+ 11.0	△
	Metal detergent (ANTI-CORROSION)	A505	25	70	- 5	- 10	+ 7.6	○
		A305	25	70	- 3	- 3	+ 2.2	○
Crude oil (KUWAIT Crude oil)	A402	25	70	- 3	- 18	+ 2.5	○	
	A505	60	70	- 4	- 16	+ 8.8	○	
FUELOIL	FUEL A	A105	25	70	- 4	- 21	+ 7.8	○
		A795	25	70	0	- 9	+ 0.4	○
	FUEL B	A105	25	70	- 17	- 53	+ 33.0	×
		A305	25	70	- 14	- 48	+ 23.4	×
		A795	25	70	- 16	- 35	+ 22	×
		F975	25	70	- 4	- 12	+ 2.2	○
	FUEL C	A305	40	70	- 17	- 61	+ 56.0	×
			240	70	- 17	- 62	+ 55.0	×
		A795	25	70	- 18	- 50	+ 32	×
			40	70	- 8	- 30	+ 9.5	
		F201	240	70	- 10	- 38	+ 15.1	
			480	70	- 11	- 41	+ 15.5	
			960	70	- 12	- 42	+ 15.7	△
			60	70	- 11	- 41	+ 18.1	
	F975	23	22	- 3	- 10	+ 2.1		
		70	70	- 3	- 14	+ 3.7		
	FUEL C + METHANOL (85:15)	A305	40	70	- 18	- 69	+ 94.0	
240			70	- 18	- 68	+ 94.0	×	
Other hydraulic oil (Hydraulic oil for aircrafts)	MIL H 5606	A980	120	70	- 21	- 19	+ 30.7	×
	MIL H 5606 C	U801	100	500	- 1	+ 5	+ 6.0	◎
	HYDRAULIC FLUID (SHOWA-SHELL)	A903	100	70	- 4	- 2	+ 6.2	○
	Caltex RPM Aviation Hydraulic Fluid G	A105	100	70	- 1	- 9	- 2.6	
			240	70	0	- 11	- 2.2	
			500	70	0	- 13	- 2.0	◎
			1000	70	0	- 15	- 1.8	◎
			2000	70	0	- 14	- 1.5	◎
			3000	70	+ 1	- 22	- 0.6	◎
			5000	70	+ 1	- 24	+ 4.3	○
			A980	100	70	- 1	- 9	- 0.9
	240	70		- 1	- 9	- 0.5		
	500	70		- 1	- 18	- 0.1	◎	
	1000	70		- 1	- 19	+ 0.3	◎	
	2000	70		- 3	- 17	+ 1.1	◎	
	3000	70		- 4	- 23	+ 5.0	◎	
	ROYAL LUBRICANTS: MIL oil (MIL H5606G)	A305	100	70	- 6	- 9	+ 13.6	
500			70	- 8	- 7	+ 13.6	○	
A567		100	70	- 12	- 19	+ 21.6		
		500	70	- 13	- 32	+ 22.1	△	
A903	100	70	- 11	- 19	+ 19.6			
	500	70	- 12	- 25	+ 19.6	△		
A980	100	70	- 15	- 21	+ 27.2			
	500	70	- 18	- 22	+ 27.9	×		

OIL RESISTANCE DATA

Brand name of sealing liquid (Manufacturer)		NOK's material symbol	Test temperature (°C)	Duration of test (H)	Change in hardness (points)	Change in tensile strength(%)	Change in volume (%)	Adaptable or not		
Other hydraulic oil	Hydraulic oil for aircrafts Chevron Aviation Hydraulic Fluid G (MIL H5606G)	A105	100	70	-10	-8	+11.7	○		
		A505	100	70	-10	+3	+11.2	○		
		A527	100	70	-16	-23	+38.5	×		
		A567	100	70	-11	-11	+18.3	△		
		A980	100	70	-15	-13	+26.0	×		
		G928	100	70	-4	-1	+12.9	○		
	Other hydraulic oil (Raw resolution hydraulic oil)	NATUREL HF (SHELL)	A105	120	70	-6	-8	+9.0	○	
			A305	100	70	-7	-2	+1.3		
				240	-6	-4	+1.4			
				500	-6	-1	+1.5	◎		
			A505	120	70	-4	+8	+8.8	○	
			A903	120	70	-5	-7	+15.4	△	
			A980	60	70	-7	+4	+7.9		
					240	-10	0	+12.5		
					500	-12	+3	+13.5	△	
				80	70	-12	+5	+13.4		
					240	-12	-2	+13.8		
					500	-13	-10	+14.2	△	
			100	70	-13	-4	+15.1			
				240	-13	-6	+15.2			
				500	-14	-7	+15.6	△		
			120	70	-14	-6	+28.0	×		
			G506	120	70	-3	-7	+4.9	◎	
			U593	60	500	-1	+14	+1.1	◎	
				80	500	-2	-7	+1.4	◎	
				100	500	-4	-50	+0.5	○	
			U641	60	500	-1	+28	+0.7	◎	
80				500	-1	+8	+0.9	◎		
100				500	-1	+7	+1.6	◎		
U801			80	500	0	+2	-0.7	◎		
			100	500	0	-63	-1.4	×		
Other hydraulic oil (Raw resolution hydraulic oil)			PLANTO HYD-40	A104	100	50	-1	+1	-3.4	
					100	100	-1	+1	-3.4	
	100	200			-1	+1	-3.4			
	100	300			-1	0	-3.3	◎		
	A105	100		72	-1	-9	+0.1			
				300	-1	-16	-0.8			
				600	0	-16	-1.4	◎		
				1000	+1	-17	-1.3	◎		
	120	70		-2	-19	+0.2	○			
	A305	100		72	-5	0	+0.1			
				300	-4	-3	-0.6			
				600	-4	-6	-0.9	◎		
				1000	-4	-5	-0.9	◎		
	120	70		-4	-3	+0.1	○			
	A505	100		72	-3	-1	+1.1			
				300	-3	+4	+1.0			
				600	-4	-4	+0.9	◎		
				1000	-3	-3	+1.1	◎		
	120	70		-4	+6	+1.9	○			
	A795	100		50	+2	-7	-3.4			
				100	+2	+1	-4.0			
				200	+2	-5	-4.1			
				300	+2	-8	-4.1	◎		
	A980	120		70	-16	-3	+19.1	×		
	G506	120		72	0	+1	-0.6			
				300	0	+3	-0.6			
				600	+1	-2	-0.6	◎		
1000			+1	-3	-0.6	◎				
U593	100	1000	-2	-30	+0.4	◎				
U641	100	1000	-1	-2	+1.4	◎				
U801	100	1000	0	-26	-0.6	◎				

DATA FOR REFERENCE

OIL RESISTANCE DATA

Brand name of sealing liquid (Manufacturer)		NOK's material symbol	Test temperature (°C)	Duration of test (H)	Change in hardness (points)	Change in tensile strength(%)	Change in volume (%)	Adaptable or not
Other hydraulic oil 〈Raw resolution hydraulic oil〉	PANOLIN HLP SYNTH46	A105	80	70	- 9	- 4	+ 11.5	○
				280	- 9	- 5	+ 11.1	
				500	- 9	- 10	+ 10.5	
		A505	80	70	- 7	- 1	+ 8.4	○
				280	- 7	- 1	+ 8.7	
				500	- 7	- 3	+ 8.1	
			110	500	- 9	+ 3	+ 9.5	△
				750	- 10	+ 1	+ 9.6	△
		1000		- 10	- 2	+ 9.8	△	
		1500		- 10	+ 5	+ 10.2	△	
		A795	100	70	+ 1	+ 1	- 0.4	○
		500	+ 5	- 20	- 0.7			
		A980	80	70	- 14	- 6	+ 28.5	×
	280			- 14	- 8	+ 28.8		
	500			- 15	- 10	+ 29.0		
	G588	110	500	- 2	+ 4	+ 13.4	○	
			750	- 1	+ 2	+ 15.0		
			1000	- 1	+ 4	+ 14.8		
			1500	- 1	- 2	+ 15.2		
	G928	80	70	- 4	- 1	+ 7.1	○	
			280	- 5	0	+ 9.9		
			500	- 5	+ 1	+ 10.1		
	MOBIL EAL 224H	A505	80	240	- 1	+ 5	+ 1.3	○
		A903	80	240	- 5	+ 3	+ 5.8	○
		G361	80	240	- 1	- 6	+ 0.7	○
		U593	100	72	0	- 2	+ 2.2	○
				140	0	+ 2	+ 2.4	
				300	- 1	+ 3	+ 2.8	
		U641	100	72	0	+ 13	+ 0.8	○
				140	0	+ 15	+ 1.0	
				300	0	+ 23	+ 1.2	
		U652	100	72	0	- 6	+ 0.6	○
				140	0	0	+ 0.7	
300				0	+ 4	+ 0.8		
U801		100	72	0	+ 3	- 0.1	○	
			140	0	+ 20	- 0.2		
			300	0	+ 18	- 0.1		
HIGH LAND Z46 (SHIN NISSEKI)	A305	100	72	- 2	+ 2	- 0.1	○	
			140	- 2	- 2	- 0.4		
	A505	80	240	- 2	+ 4	+ 0.4	○	
	A903	80	240	- 2	- 4	+ 2.8	○	
	G361	80	240	- 1	0	+ 0.2	○	
	U593	100	72	0	+ 1	+ 2.3	○	
			140	0	+ 4	+ 2.4		
			300	- 1	+ 4	+ 2.9		
	U641	100	70	- 1	+ 9	+ 1.4	○	
			500	- 1	- 1	+ 1.5		
			1000	- 1	- 6	+ 1.7		
			2000	- 1	- 10	+ 2.6		
	U652	100	72	0	- 3	+ 0.8	○	
			140	0	- 4	+ 0.8		
			300	0	- 9	+ 1.0		
U801	100	70	- 1	- 12	+ 0.2	○		
		500	- 3	- 17	+ 0.3			
		1000	- 3	- 24	+ 0.6			
		2000	- 3	- 27	+ 0.6			
UH04	100	70	- 1	+ 12	+ 0.8	○		
		500	- 3	- 10	+ 1.7			
		1000	- 3	- 11	+ 2.1			
		2000	- 3	- 14	+ 2.8			

OIL RESISTANCE DATA

Brand name of sealing liquid (Manufacturer)		NOK's material symbol	Test temperature (°C)	Duration of test (H)	Change in hardness (points)	Change in tensile strength(%)	Change in volume (%)	Adaptable or not
Other hydraulic oil (Raw resolution hydraulic oil)	DAFFNEY VIOS HYDRO 46SE (IDEMITSU)	A105	100	70	- 2	- 9	+ 2.4	
				280	- 2	- 9	+ 0.9	
				500	- 3	- 14	+ 1.2	○
		120	70	- 3	- 17	+ 2.1		
			280	- 3	- 21	+ 1.9		
			500	- 3	- 33	+ 2.1	△	
		A505	100	70	- 2	+ 5	+ 2.4	
				280	- 2	+ 5	+ 2.1	
				500	- 3	+ 6	+ 1.9	○
		120	70	- 3	+ 1	+ 2.7		
			280	- 3	+ 4	+ 2.8		
			500	- 5	+ 5	+ 3.4	○	
		A980	100	70	- 9	+ 3	+ 13.9	
				280	- 11	- 7	+ 14.3	
				500	- 11	- 8	+ 14.7	△
		120	70	- 13	- 16	+ 20.7		
			280	- 17	- 28	+ 25.6		
			500	- 17	- 23	+ 23.2	×	
		G928	100	70	- 2	- 3	+ 3.1	
				280	- 3	- 2	+ 4.0	
				500	- 4	- 3	+ 4.5	○
		120	70	- 3	- 3	+ 3.9		
			280	- 4	- 2	+ 4.3		
			500	- 4	- 4	+ 4.5	○	
U641	100	70	0	- 1	+ 1.4			
		280	0	+ 1	+ 2.4			
		500	0	0	+ 2.4	○		
120	70	- 2	- 4	+ 2.2				
	280	- 1	- 13	+ 2.8				
	500	- 1	- 25	+ 2.8	○			
U801	100	70	- 1	+ 5	+ 0.7			
		280	- 1	- 3	+ 1.0			
		500	0	- 1	+ 0.9	○		
120	70	0	+ 1	+ 0.9				
	280	0	- 15	+ 1.2				
	500	- 1	- 38	+ 1.1	○			
NATUREL HF-E46 (SHELL)	A105	100	70	- 4	- 10	+ 4.0		
			280	- 5	- 10	+ 4.1		
			500	- 6	- 14	+ 4.8	○	
	120	70	- 6	- 14	+ 6.8			
		280	- 7	- 27	+ 5.7			
		500	- 8	- 22	+ 5.7	△		
	A505	100	70	- 5	+ 6	+ 6.4		
			280	- 6	+ 7	+ 6.5		
			500	- 6	- 2	+ 6.7	○	
	120	70	- 6	+ 4	+ 7.8			
		280	- 8	- 5	+ 7.9			
		500	- 9	- 9	+ 8.3	△		
	A980	100	70	- 12	- 6	+ 19.8		
			280	- 16	- 16	+ 21.3		
			500	- 16	- 18	+ 20.6	×	
	120	70	- 13	- 16	+ 20.7			
		280	- 17	- 28	+ 25.6			
		500	- 17	- 23	+ 23.2	×		
	G928	100	70	- 3	- 3	+ 4.5		
			280	- 4	- 2	+ 6.2		
			500	- 4	- 4	+ 7.2	○	
	120	70	- 4	- 3	+ 6.6			
		280	- 5	- 1	+ 7.5			
		500	- 6	- 3	+ 9.2	○		

OIL RESISTANCE DATA

Brand name of sealing liquid (Manufacturer)		NOK's material symbol	Test temperature (°C)	Duration of test (H)	Change in hardness (points)	Change in tensile strength (%)	Change in volume (%)	Adaptable or not					
Other hydraulic oil	NATUREL HF-E46 (SHELL) (Raw resolution hydraulic oil)	U641	100	70	0	+ 9	+ 2.8	○					
				280	0	+ 6	+ 3.9						
				500	0	- 11	+ 4.0						
		U801	100	70	- 1	- 4	+ 3.9	△					
				280	- 1	- 38	+ 5.1						
				500	- 2	- 56	+ 5.2						
		Others	Water and Vapor	A105	100	70	+ 3	- 16	- 0.1	○			
						A168	120	70	+ 5	- 41	- 0.8	△	
						A305	100	70	- 4	- 3	+ 3.8	○	
				U641	25	35040	70	- 1	- 11	+ 3.8	○		
							U695	80	1000	0	- 7	+ 1.4	○
							98	1000	- 2	- 43	+ 1.5	○	
U801	70	1000	70	- 1	- 28	+ 1.0	○						
			100	200	- 3	- 79	+ 1.5	×					
			Muddy water	U641	25	35040	- 1	- 11	+ 0.3	○			
COLA	A104	25	100	- 5	-	+ 1.4	○						
				A168	25	100	- 1	-	+ 1.1	○			
				A305	25	100	- 3	-	+ 1.4	○			
METHANOL	A305	40	70	- 12	- 41	+ 14.0	×						
			240	- 10	- 38	+ 12.0							
	F201	40	70	- 20	-	+ 76.5	×						

FITTING TOLERANCE FOR SHAFT

Unit 0.001mm

FITTING TOLERANCE FOR SHAFT (JIS B 0401)

Classification of nominal sizes (mm)	IT 5		IT 6		IT 7		IT 8		IT 9		IT 10		IT 11	
	Upper tolerance	Lower tolerance	Upper tolerance	Lower tolerance	Upper tolerance	Lower tolerance	Upper tolerance	Lower tolerance	Upper tolerance	Lower tolerance	Upper tolerance	Lower tolerance	Upper tolerance	Lower tolerance
1 - 3	+6 +4	+4 +2	+16 +10	+12 +6	+8 +2	+6 +0	+10 +4	+6 +0	+14 +8	+10 +4	+14 +8	+10 +4	+14 +8	+10 +4
3 - 6	+9 +6	+4 +1	+23 +15	+20 +12	+9 +4	+7 +1	+12 +8	+8 +4	+18 +12	+12 +8	+18 +12	+12 +8	+18 +12	+12 +8
6 - 10	+12 +7	+4 +1	+28 +19	+24 +15	+10 +6	+7 +2	+15 +10	+10 +6	+25 +16	+15 +10	+25 +16	+15 +10	+25 +16	+15 +10
10 - 14	+15 +9	+5 +3	+34 +23	+29 +18	+12 +7	+8 +3	+16 +11	+12 +7	+32 +21	+21 +14	+32 +21	+21 +14	+32 +21	+21 +14
14 - 18	+17 +11	+5 +2	+41 +28	+35 +22	+15 +8	+9 +4	+19 +13	+15 +8	+43 +29	+29 +19	+43 +29	+29 +19	+43 +29	+29 +19
18 - 24	+20 +13	+6 +2	+50 +34	+42 +26	+17 +9	+11 +5	+25 +16	+17 +9	+51 +34	+34 +22	+51 +34	+34 +22	+51 +34	+34 +22
24 - 30	+24 +15	+6 +2	+60 +41	+51 +32	+20 +11	+12 +7	+30 +20	+20 +11	+62 +41	+41 +27	+62 +41	+41 +27	+62 +41	+41 +27
30 - 40	+28 +13	+6 +3	+73 +59	+62 +43	+23 +13	+13 +8	+35 +25	+23 +13	+86 +62	+62 +43	+86 +62	+62 +43	+86 +62	+62 +43
40 - 50	+33 +21	+7 +3	+90 +65	+76 +54	+25 +15	+16 +10	+40 +25	+25 +15	+100 +65	+65 +43	+100 +65	+65 +43	+100 +65	+65 +43
50 - 65	+43 +27	+7 +4	+126 +94	+108 +77	+32 +19	+20 +12	+52 +35	+32 +19	+146 +94	+94 +63	+146 +94	+94 +63	+146 +94	+94 +63
65 - 80	+46 +29	+7 +4	+150 +113	+130 +98	+36 +23	+21 +13	+58 +40	+36 +23	+170 +113	+113 +84	+170 +113	+113 +84	+170 +113	+113 +84
80 - 100	+50 +32	+8 +4	+166 +126	+144 +114	+40 +25	+24 +14	+66 +44	+40 +25	+190 +126	+126 +98	+190 +126	+126 +98	+190 +126	+126 +98
100 - 120	+55 +35	+9 +5	+188 +148	+168 +128	+46 +30	+27 +16	+84 +54	+46 +30	+210 +148	+148 +108	+210 +148	+148 +108	+210 +148	+148 +108
120 - 140	+60 +38	+10 +6	+210 +158	+188 +148	+52 +35	+32 +20	+108 +77	+52 +35	+230 +158	+158 +108	+230 +158	+158 +108	+230 +158	+158 +108
140 - 160	+66 +40	+11 +7	+242 +188	+210 +150	+60 +40	+36 +24	+126 +84	+60 +40	+260 +188	+188 +130	+260 +188	+188 +130	+260 +188	+188 +130
160 - 180	+72 +46	+12 +8	+270 +210	+238 +178	+68 +46	+40 +26	+144 +98	+68 +46	+290 +210	+210 +148	+290 +210	+210 +148	+290 +210	+210 +148
180 - 200	+78 +50	+13 +8	+300 +226	+268 +198	+76 +50	+46 +28	+162 +108	+76 +50	+320 +226	+226 +158	+320 +226	+226 +158	+320 +226	+226 +158
200 - 225	+84 +56	+14 +9	+330 +242	+298 +214	+84 +56	+50 +30	+180 +126	+84 +56	+350 +242	+242 +170	+350 +242	+242 +170	+350 +242	+242 +170
225 - 250	+90 +58	+15 +10	+360 +270	+328 +238	+92 +60	+56 +34	+200 +144	+92 +60	+380 +270	+270 +190	+380 +270	+270 +190	+380 +270	+270 +190
250 - 280	+96 +60	+16 +10	+390 +294	+358 +254	+100 +66	+60 +36	+220 +156	+100 +66	+410 +294	+294 +210	+410 +294	+294 +210	+410 +294	+294 +210
280 - 315	+102 +64	+17 +11	+420 +318	+388 +274	+108 +70	+66 +38	+240 +168	+108 +70	+440 +318	+318 +230	+440 +318	+318 +230	+440 +318	+318 +230
315 - 355	+108 +70	+18 +12	+450 +342	+418 +298	+116 +76	+70 +40	+260 +180	+116 +76	+470 +342	+342 +250	+470 +342	+342 +250	+470 +342	+342 +250
355 - 400	+114 +76	+19 +13	+480 +366	+448 +314	+124 +80	+76 +42	+280 +196	+124 +80	+500 +366	+366 +270	+500 +366	+366 +270	+500 +366	+366 +270
400 - 450	+120 +80	+20 +14	+510 +396	+478 +344	+132 +86	+80 +44	+300 +210	+132 +86	+530 +396	+396 +300	+530 +396	+396 +300	+530 +396	+396 +300
450 - 500	+126 +86	+21 +15	+540 +414	+508 +362	+140 +90	+86 +46	+320 +220	+140 +90	+560 +414	+414 +320	+560 +414	+414 +320	+560 +414	+414 +320

DATA FOR REFERENCE

FITTING TOLERANCE FOR BORE

Unit 0.001mm

FITTING TOLERANCE FOR BORE (JIS B 0401)

Classification of nominal sizes (mm)	IT 6																IT 7																IT 8																IT 9				IT 10				IT 12			
	M 6				K 6				J 6				H 6				F 6				IT				Upper tolerance				Lower tolerance				Upper tolerance				Lower tolerance				Upper tolerance				Lower tolerance															
	U 7	T 7	S 7	R 7	P 7	N 7	M 7	K 7	J 7	H 7	G 7	F 7	E 7	IT	H 8	F 8	E 8	D 8	IT	H 9	E 9	D 9	C 9	IT	H 10	D 10	C 10	B 10	IT	H 12	Upper tolerance	Lower tolerance																												
1 - 3	6	-2 + 0	+ 2	+ 6	+ 8	+ 12	10	-18	-14	-10	-6	-4	-2	0	+ 3	+ 10	+ 12	+ 16	+ 24	14	+ 14	+ 20	+ 28	+ 34	25	+ 25	+ 39	+ 45	+ 85	+ 40	+ 60	+ 100	+ 180	100	+ 100																									
3 - 6	8	-1 + 2	+ 4	+ 8	+ 12	+ 18	12	-19	-15	-11	-8	-4	0	+ 3	+ 5	+ 12	+ 16	+ 22	+ 32	18	+ 18	+ 28	+ 38	+ 48	30	+ 30	+ 50	+ 60	+ 100	+ 188	+ 120	+ 120	+ 120	+ 120																										
6 - 10	9	-3 + 2	+ 5	+ 9	+ 14	+ 22	15	-22	-17	-13	-9	-4	0	+ 5	+ 8	+ 15	+ 20	+ 28	+ 40	22	+ 22	+ 35	+ 47	+ 62	36	+ 36	+ 61	+ 76	+ 116	+ 208	+ 150	+ 150	+ 150	+ 150	+ 150																									
10 - 14	11	-4 + 2	+ 6	+ 11	+ 17	+ 27	18	-26	-21	-16	-11	-5	0	+ 6	+ 10	+ 18	+ 24	+ 34	+ 50	27	+ 27	+ 43	+ 59	+ 77	43	+ 43	+ 75	+ 93	+ 138	+ 220	+ 180	+ 180	+ 180	+ 180	+ 180																									
14 - 18		-15 - 9	- 5	0	6	16		-44	-39	-34	-29	-23	-18	-12	-8	0	6	16	32																																									
18 - 24		-4 + 2	+ 8	+ 13	+ 20	+ 33	21	-33	-27	-20	-14	-7	0	+ 6	+ 12	+ 21	+ 28	+ 41	+ 61	33	+ 33	+ 53	+ 73	+ 98	52	+ 52	+ 92	+ 117	+ 162	+ 244	+ 210	+ 210	+ 210	+ 210	+ 210																									
24 - 30		-17 - 11	- 5	0	7	20		-40	-33	-28	-21	-15	-9	-5	0	7	20	40																																										
30 - 40		-4 + 3	+ 10	+ 16	+ 25	+ 41	25	-51	-45	-39	-32	-25	-18	-11	-7	0	9	25	50																																									
40 - 50		-20 - 13	- 6	0	9	25		-61	-45	-39	-32	-25	-18	-11	-7	0	9	25	50																																									
50 - 65		-5 + 4	+ 13	+ 19	+ 29	+ 49	30	-76	-64	-54	-44	-34	-25	-17	-8	0	7	34	60																																									
65 - 80		-24 - 15	- 6	0	10	30		-91	-78	-66	-54	-42	-33	-25	-18	-11	-7	30	60																																									
80 - 100		-6 + 4	+ 16	+ 22	+ 34	+ 58	35	-111	-93	-81	-73	-64	-54	-44	-34	-25	-17	-8	35																																									
100 - 120		-28 - 18	- 6	0	12	36		-131	-113	-101	-93	-84	-74	-64	-54	-44	-34	-25	-17	-8																																								
120 - 140								-166	-147	-135	-127	-119	-111	-101	-91	-81	-71	-61	-51																																									
140 - 160		-8 + 4	+ 16	+ 25	+ 39	+ 68	40	-119	-101	-89	-81	-73	-64	-54	-44	-34	-25	-17	-8																																									
160 - 180		-33 - 21	- 7	0	14	43		-159	-141	-129	-121	-113	-104	-94	-84	-74	-64	-54	-44																																									
180 - 200								-171	-153	-141	-133	-125	-117	-109	-101	-93	-85	-77	-69																																									
200 - 225		-8 + 5	+ 22	+ 29	+ 44	+ 79	46	-113	-95	-83	-75	-67	-59	-51	-43	-35	-27	-19	-11																																									
225 - 250		-37 - 24	- 7	0	15	50		-159	-141	-129	-121	-113	-104	-94	-84	-74	-64	-54	-44																																									
250 - 280								-126	-108	-96	-88	-80	-72	-64	-56	-48	-40	-32	-24																																									
280 - 315		-9 + 5	+ 25	+ 32	+ 49	+ 88	52	-78	-66	-54	-42	-30	-18	-6	6	16	36	62	110																																									
315 - 355		-10 + 7	+ 29	+ 36	+ 54	+ 98	57	-87	-74	-62	-50	-38	-26	-14	-2	8	18	38	62																																									
355 - 400		-46 - 29	- 7	0	18	62		-93	-81	-69	-57	-45	-33	-21	-9	3	18	38	62																																									
400 - 450		-10 + 8	+ 33	+ 40	+ 60	+ 108	63	-103	-91	-79	-67	-55	-43	-31	-19	-7	7	17	37																																									
450 - 500		-50 - 32	- 7	0	20	68		-109	-97	-85	-73	-61	-49	-37	-25	-13	-1	9	19																																									

STANDARD FITTING TOLERANCE FOR LARGE DIAMETER (JIS B 0401)

Unit : 0.001mm

Classification of nominal sizes (mm)		Tolerance of shaft			Tolerance of hole			
		h9	h10	f8	H7	H8	H9	H10
Above	Below	Upper tolerance Lower tolerance			Upper tolerance Lower tolerance			
500	630	0 -175	0 -280	-76 -186	+70 0	+110 0	+175 0	+280 0
630	800	0 -200	0 -320	-80 -205	+80 0	+125 0	+200 0	+320 0
800	1000	0 -230	0 -360	-86 -226	+90 0	+140 0	+230 0	+360 0
1000	1250	0 -260	0 -420	-98 -263	+105 0	+165 0	+260 0	+420 0
1250	1600	0 -310	0 -500	-110 -305	+125 0	+195 0	+310 0	+500 0
1600	2000	0 -370	0 -600	-120 -350	+150 0	+230 0	+370 0	+600 0

TABLE OF MAJOR SI UNIT CONVERSION

Unit shown in bold line represents SI unit.

Force	N	dyn	kgf
	1	1×10^5	$1.019\ 72 \times 10^{-1}$
	1×10^{-5}	1	$1.019\ 72 \times 10^{-6}$
	9.806 65	9.80665×10^5	1

Viscosity	Pa·s	cp	P
	1	1×10^3	1×10
	1×10^{-3}	1	1×10^{-2}
	1×10^{-1}	1×10^2	1

Note : 1P = 1dyn·s/cm² = 1g/cm·s, 1Pa·s = 1N·s/m², 1cP = 1mPa·s

Pressure	Pa	kPa	MPa	bar	kgf/cm ²	atm	mmH ₂ O	mmHg or Torr
	1	1×10^{-3}	1×10^{-6}	1×10^{-5}	$1.019\ 72 \times 10^{-5}$	$9.869\ 23 \times 10^{-6}$	$1.019\ 72 \times 10^{-1}$	$7.500\ 62 \times 10^3$
	1×10^3	1	1×10^{-3}	1×10^{-2}	$1.019\ 72 \times 10^{-2}$	$9.869\ 23 \times 10^{-3}$	$1.019\ 72 \times 10^2$	7.500 62
	1×10^6	1×10^3	1	1×10	$1.019\ 72 \times 10$	9.869 23	$1.019\ 72 \times 10^5$	$7.500\ 62 \times 10^3$
	1×10^9	1×10^2	1×10^{-1}	1	1.019 72	$9.869\ 23 \times 10^{-1}$	$1.019\ 72 \times 10^4$	$7.500\ 62 \times 10^2$
	$9.806\ 65 \times 10^4$	$9.806\ 65 \times 10$	$9.806\ 65 \times 10^{-2}$	$9.806\ 65 \times 10^{-1}$	1	$9.678\ 41 \times 10^{-1}$	1×10^4	7.35559×10^2
	$1.013\ 25 \times 10^5$	$1.013\ 25 \times 10^2$	$1.013\ 25 \times 10^{-1}$	1.013 25	1.033 23	1	$1.033\ 23 \times 10^4$	$7.600\ 00 \times 10^2$
	9.806 65	$9.806\ 65 \times 10^{-3}$	$9.806\ 65 \times 10^{-6}$	$9.806\ 65 \times 10^{-5}$	1×10^{-4}	$9.678\ 41 \times 10^{-5}$	1	$7.355\ 59 \times 10^{-2}$
	$1.333\ 22 \times 10^2$	$1.333\ 22 \times 10^{-1}$	$1.333\ 22 \times 10^{-4}$	$1.333\ 22 \times 10^{-3}$	$1.359\ 51 \times 10^{-3}$	$1.315\ 79 \times 10^{-3}$	$1.359\ 51 \times 10$	1

Note : 1Pa = 1N/m²

Stress	Pa or N/m ²	MPa or N/mm ²	kgf	kgf/cm ²
	1	1×10^{-6}	$1.019\ 72 \times 10^{-7}$	$1.019\ 72 \times 10^{-5}$
	1×10^6	1	$1.019\ 72 \times 10^{-1}$	$1.019\ 72 \times 10$
	$9.806\ 65 \times 10^6$	9.806 65	1	1×10^2
	$9.806\ 65 \times 10^4$	$9.806\ 65 \times 10^{-2}$	1×10^{-2}	1

Note : 1Pa = 1N/m², 1MPa = 1N/mm²

Dynamic viscosity	m ² /s	cSt	St
	1	1×10^6	1×10^4
	1×10^{-6}	1	1×10^2
	1×10^{-4}	1×10^2	1

Note : 1St = 1cm²/s, 1cSt = 1mm²/s

TABLE OF HARDNESS CONVERSION

Approximate conversion value for Rockwell ASTM hardness C of steel					
Hardness by Rockwell C scale	Vickers hardness	Brinell hardness 300kg Standard ball	Rockwell hardness B scale Load 100kg Dia. of ball: 1/16 in.	Shore hardness	Hardness by Rockwell C scale
68	940	-	-	97	68
67	900	-	-	95	67
66	865	-	-	92	66
65	832	-	-	91	65
64	800	-	-	88	64
63	772	-	-	87	63
62	746	-	-	85	62
61	720	-	-	83	61
60	697	-	-	81	60
59	674	-	-	80	59
58	653	-	-	78	58
57	633	-	-	76	57
56	613	-	-	75	56
55	595	-	-	74	55
54	577	-	-	72	54
53	560	-	-	71	53
52	544	500	-	69	52
51	528	487	-	68	51
50	513	475	-	67	50
49	498	464	-	66	49
48	484	451	-	64	48
47	471	442	-	63	47
46	458	432	-	62	46
45	446	421	-	60	45
44	434	409	-	58	44
43	423	400	-	57	43
42	412	390	-	56	42
41	402	381	-	55	41
40	392	371	-	54	40
39	382	362	-	52	39
38	372	358	-	51	38
37	363	344	-	50	37
36	354	336	(109.0)	49	36
35	345	327	(108.5)	48	35
34	336	319	(108.0)	47	34
33	327	311	(107.5)	46	33
32	318	301	(107.0)	44	32
31	310	294	(106.0)	43	31
30	302	286	(105.5)	42	30
29	294	279	(104.5)	41	29
28	286	271	(104.0)	41	28
27	279	264	(103.0)	40	27
26	272	258	(102.5)	38	26
25	266	253	(101.5)	38	25
24	260	247	(101.0)	37	24
23	254	243	(100.0)	36	23
22	248	237	(99.0)	35	22
21	243	231	(98.5)	35	21
20	238	226	97.8	34	20
(18)	230	219	96.7	33	(18)
(16)	222	212	95.5	32	(16)
(14)	213	203	93.9	31	(14)
(12)	204	194	92.3	29	(12)
(10)	196	187	90.7	28	(10)
(8)	188	179	89.5	27	(8)
(6)	180	171	87.1	26	(6)
(4)	173	165	85.5	25	(4)
(2)	166	158	83.5	24	(2)
(0)	160	152	81.7	24	(0)

RANGE OF ROUGHNESS BY VARIOUS METHODS OF PROCESSING

Method of processing	Range of roughness Rz (µm)	0.1	0.2	0.4	0.8	1.5	3	6	12	25	50	100	200	400
		Below	Below	Below	Below	Below	Below	Below	Below	Below	Below	Below	Below	Below
Forging	FG													
Casting	C													
Die casting	DC													
Hot rolling	HR													
Cold rolling	CR													
Drawing	DW													
Extrusion	EX													
Tumbling	TU													
Sand-blasting	SB													
Roll lining	RL													
Face milling	FM													
Planing	P													
Slotting	SL													
Milling	M													
Fine boring	FB													
Filing finish	FF													
Turning	T													
Boring	B													
Drilling	D													
Reaming	DR													
Broaching	BR													
Shaving	SV													
Grinding	G													
Honing finish	GH													
Super finish	GSP													
Buffing finish	SPBF													
Paper finish	FCA													
Lapping finish	FL													
Liquid honing	SPLH													
Burnishing	RLB													
Roller finish	RF													
Chemical polishing	SPC													
Electrolytic polishing	SPE													

CHANGE OF SURFACE ROUGHNESS JIS STANDARD

Standard No.	JIS B 0601 : 1982	JIS B 0601 : 1994	JIS B 0601 : 2001
Comparison and use	JIS B 0031 : 1982	JIS B 0031 : 1994	
Profile curve	Without filter	Without filter	λc filter
Evaluation length	1 Reference length	-	Length of shape
Maximum height	R max	-	Pt
Average roughness of 10 points	Rz	-	-
Roughness curve	2 Rc λc filter	Phase compensation λc filter	Phase compensation λc filter + λs filter
Evaluation length	1 Reference length	5 Reference length	5 Reference length
Maximum height	-	Maximum height: Ry	Maximum height: Rz
Average roughness of 10 points	-	Rz	Rz JIS
Average roughness of center point	Ra	Ra 75	Ra 75
Arithmetic average roughness	-	Ra	Ra
Average interval between convexities and concavities	-	Average interval between concavities and convexities: Sm	Average length of roughness curve element: RSm
Local peak interval	-	Local peak average interval: S	-
Load length rate	-	tp (on per-reference-length basis)	Rmr (entire evaluation length)
Other height parameters	-	-	Rp, Rv, Rt, Rc, Rq
Height feature parameter	-	-	Rsk, Rku,
Composite parameter and others	-	-	RΔq, Rσc, Rmr

Table of viscosity conversion

Seyboldt SUS (sec)	Red wood R (sec)	Engler E (sec)	Centi-stokes cSt	Seyboldt SUS (sec)	Red wood R (sec)	Engler E (sec)	Centi-stokes cSt
35	32.2	1.18	2.7	475	419	13.5	103
40	36.2	1.32	4.3	500	441	14.2	108
45	40.6	1.46	5.9	550	485	15.6	119
50	44.9	1.60	7.4	600	529	17.0	130
55	49.1	1.75	8.9	650	573	18.5	141
60	53.5	1.88	10.4	700	617	19.9	152
65	57.9	2.02	11.8	750	661	21.3	163
70	62.3	2.15	13.1	800	705	22.7	173
75	67.6	2.31	14.5	850	749	24.2	184
80	71.0	2.42	15.8	900	793	25.6	195
85	75.1	2.55	17.0	950	837	27.0	206
90	79.6	2.68	18.2	1000	882	28.4	217
95	84.2	2.81	19.4	1200	1058	34.1	260
100	88.4	2.95	20.6	1400	1234	39.8	302
110	97.1	3.21	23.0	1600	1411	45.5	347
120	105.9	3.49	25.0	1800	1587	51	390
130	114.8	3.77	27.5	2000	1763	57	433
140	123.6	4.04	29.8	2500	2204	71	542
150	132.4	4.32	32.1	3000	2646	85	650
160	141.1	4.59	34.3	3500	3087	99	758
170	150.0	4.88	36.5	4000	3526	114	867
180	158.8	5.15	38.8	4500	3967	128	974
190	167.5	5.44	41.0	5000	4408	142	1082
200	176.4	5.72	43.2	5500	4849	156	1150
220	194	6.28	47.5	6000	5290	170	1300
240	212	6.85	51.9	6500	5730	185	1400
260	229	7.38	56.5	7000	6171	199	1510
280	247	7.95	60.5	7500	6612	213	1630
300	265	8.51	64.9	8000	7053	227	1740
325	287	9.24	70.3	8500	7494	242	1850
350	309	9.95	75.8	9000	7943	256	1960
375	331	10.7	81.2	9500	8375	270	2070
400	353	11.4	86.8	10000	8816	284	2200
425	375	12.1	92.0				
450	397	12.8	97.4				

How to read the Table :

For example, when converting 38°C into °F, find out 38 from the 2nd row of the table (10th position from the top) at the center column and then read the figure in the column °F on the right side. You will thus find out 100,4 °F. To the contrary, you can convert 38° F into °C by reading the figure in the column °C on the left side and then you can know that it correspond to 33°C.

$$C = \frac{5}{9}(F - 32) \quad F = \frac{9}{5}C + 32$$

Table of temperature conversion

°C ← °F	°C → °F	°C ← °F	°C → °F	°C ← °F	°C → °F	°C ← °F	°C → °F				
-73	-100	-148	-1.6	29	84.2	17.7	64	147.2	37.1	99	210.2
-62	-80	-112	-1.1	30	86.0	18.2	65	149.0	37.7	100	212.0
-51	-60	-76	-0.6	31	87.8	18.8	66	150.8	38	100	212
-40	-40	-40	0	32	89.6	19.3	67	152.6	43	110	230
-29	-20	-4	0.5	33	91.4	19.9	68	154.4	49	120	248
-23.3	-10	14	1.1	34	93.2	20.4	69	156.2	54	130	266
-17.7	0	32	1.6	35	95.0	21.0	70	158.0	60	140	284
-17.2	1	33.8	2.2	36	96.8	21.5	71	159.8	65	150	302
-16.6	2	35.6	2.7	37	98.6	22.2	72	161.8	71	160	320
-16.1	3	37.4	3.3	38	100.4	22.7	73	163.4	76	170	338
-15.5	4	39.2	3.8	39	102.2	23.3	74	165.2	83	180	356
-15.0	5	41.0	4.4	40	104.0	23.8	75	167.0	88	190	374
-14.4	6	42.8	4.9	41	105.8	24.4	76	168.8	93	200	392
-13.9	7	44.6	5.5	42	107.6	25.0	77	170.6	121	250	482
-13.3	8	46.4	6.0	43	109.4	25.5	78	172.4	149	300	572
-12.7	9	48.2	6.6	44	111.2	26.2	79	174.2	177	350	662
-12.2	10	50.0	7.1	45	113.0	26.8	80	176.0	204	400	752
-11.6	11	51.8	7.7	46	114.8	27.3	81	177.8	232	450	842
-11.1	12	53.6	8.2	47	116.6	27.7	82	179.6	260	500	932
-10.5	13	55.4	8.8	48	118.4	28.2	83	181.4	288	550	1022
-10.0	14	57.2	9.3	49	120.2	28.8	84	183.2	315	600	1112
-9.4	15	59.0	9.9	50	122.0	29.3	85	185.0	343	650	1202
-8.8	16	61.8	10.4	51	123.8	29.9	86	186.8	371	700	1292
-8.3	17	63.6	11.1	52	125.6	30.4	87	188.6	399	750	1382
-7.7	18	65.4	11.5	53	127.4	31.0	88	190.4	426	800	1472
-7.2	19	67.2	12.1	54	129.2	31.5	89	192.2	454	850	1562
-6.6	20	68.0	12.6	55	131.0	32.1	90	194.0	482	900	1652
-6.1	21	69.8	13.2	56	132.8	32.6	91	195.8	510	950	1742
-5.5	22	71.6	13.7	57	134.6	33.3	92	197.6	538	1000	1832
-5.0	23	73.4	14.3	58	136.4	33.8	93	199.4	538	1000	1832
-4.4	24	75.2	14.8	59	138.2	34.4	94	201.2	593	1100	2012
-3.9	25	77.0	15.6	60	140.0	34.9	95	203.0	648	1200	2192
-3.3	26	78.8	16.1	61	141.8	35.5	96	204.8	704	1300	2372
-2.8	27	80.6	16.8	62	143.6	36.1	97	206.6	760	1400	2552
-2.2	28	82.4	17.1	63	145.4	36.6	98	208.4	815	1500	2732

DATA FOR REFERENCE

■ KLUEBER LUBRICANT FOR SEALS

WHAT IS NOK KLUEBER

NOK established NOK KLÜBER Co. Ltd through a merger with Klüber Lubrication München SE & Co.KG of Germany, which has over a century of experience in the field of specialized lubricants, and also supplies KLUBER lubricants for oil seal use.

NOK KLUBER combines proven technologies from both companies, resolving various lubrication problems by utilizing our vast experience and extensive developmental activities.

NOK KLUBER has established a complete system to respond to user needs for extreme conditions, such as high or low temperatures, high speeds, or high loads, based on our unparalleled experience.

Types of NOK KLUEBER lubricants

● General purpose

Roller bearings, sliding bearings, chains, gears, valves, etc.

● Lubricants for special applications

For oxygen, vacuum, radioactivity, sliding faces food machinery, textile machinery, various conveyors and so on.

● Other special lubricants

Fluorene base lubricants, silicone oil type lubricant, special release agent, anticorrosive agent, lubricant for seals.

For details, refer to the **Special Lubricants Catalog (Cat. 910)**.

NOK KLUEBER LUBRICANT FOR SEALS

Application	Grease Name	Effect on Rubber ^{Note(1)}					Working temperature range (°C)	Consistency (NLGI)	Examples of use	Features
		Nitrile rubber	Acrylic rubber	Silicone rubber	Fluoro-carbon rubber	Ethylene propylene rubber				
General	SEALUB S-1	○	○	○	○	×	-30~120	2号	Automobiles, construction machinery, agricultural machinery	General-purpose lubricant for use with rubber
Water resistant	SEALUB S-8	○	○	×	○	○	-45~160	3号	Automobiles, household appliances	Excellent resistance to water and steam
Low temperature/high speed	SEALUB S-14	○	○	○	○	×	-50~150	2号	Automobiles, household electrical appliances, industrial equipment	May be used in extremely low and high temperature conditions
For assembly	SEALUB L101	○	○	○	○	○ ^{Note(2)}	-30~90	—	Assembly/insertion of seal parts	Quick-drying assembly wax and spray products
To prevent adhesion	Klüber L604	○	○	○	○	○	-25~260	Oil	For assembly and to prevent adhesion of seal parts Lubrication of electrical contacts and plastic parts, high-temperature sliding	High-temperature fluorine oil, anti-adhesive oil and spray products
Food processing machinery	Klübersynth UH1 64-2403	○	○	○	○	×	-10~140	3号	Food/beverage manufacturing equipment	Excellent resistance to water and steam NSF H1 register*
	PARALIQ GTE 703	○	○	×	○	○	-50~150	3号		
High temperature/solvent resistant/chemicals	BARRIERTA L 55/2 H1	○	○	○	○	○	-30~260	2号	Automobiles, chemical plant equipment	Excellent resistance to heat, solvents, and chemicals NSF H1 register*

Note(1) Effects on rubber

- : Resistance
- × : No resistance

※ NSF H1 lubricant

Lubricant can be used at locations that may touch the food incidentally or necessarily.

(Effects on rubber being of average evaluation, check prior to usage, if the lubricant to be used is suitable for the required conditions.)

Note(2) Figures supplied for effective ingredients only

LINE-UP OF NOK PRODUCTS

Sealing products



Oil seals

- Oil seals
- Packings
- O-rings
- Metal gaskets "SOFTMETAL"
- Seal washers
- Mechanical seals
- Lip seals
- Segment seals
- Brush seals
- Static metal packings actiseals
- Perfluoroelastomer "KALREZ"
- Magnetic fluid seals

Industrial rubber & resin products



Polyurethane rubber "IRON RUBBER" products

- Industrial rubber products
- Iron rubber products
- Iron rubber belts
- Traffic signs & Safety devices
- Engineering plastic products
- Synthetic rubber "NOXTITE"
- Industrial chemical products "CHEMINOX"
- Phenolic molding material

Vibration damping products Sound isolator products



Anti-vibration rubber

- Vibration damping products
- Sound isolator products

Fluid power equipment



Accumulators

- Accumulators
- Housing and related equipments

Plant equipment



Metal bellows (Welding bellows)

- Metal bellows
- Couplings

Electronics products



Flexible circuits

- Flexible printed circuit
- Precision rubber / resin parts

Industrial function parts & special parts



Special lubricant

- Polymer hollow fiber membrane modules
- Solenoids
- Actuators
- Oil-less bearing "LUBLESS"
- Adapters for cable breaking "SY JOINT"
- Special lubricant
- Fluorine base coating material "GLEITPAN"
- Fluorine base water repellent & oil repellent agents "NOXBARRIER"
- Compressor valves
- Recoil starters

OA equipment products



OA equipment products

- OA equipment products



© **NOK CORPORATION** Printed in Japan

Overseas Sales & Marketing Department Sales & Marketing Division
1-12-15 Shiba Daimon Minato-ku, Tokyo, Japan. Zipcord 105-8585.

The contents is subject to change without notice.

All compatibility data, application information, design & material information and technical deta in this catalogue are compiled as a reference material to make a basic packing selection.
A selected standard design from this catalogue may not conform to the actual use of an application, clue to unknown factors in the application.
Please confirm the actual compatibility of a selected product with your application before using it.